

PAPER • OPEN ACCESS

Anaerobic Co-digestion of Cow Dung and Rice Straw to Produce Biogas using Semi-Continuous Flow Digester: Effect of Urea Addition

To cite this article: A Haryanto *et al* 2018 *IOP Conf. Ser.: Earth Environ. Sci.* **147** 012032

View the [article online](#) for updates and enhancements.

Related content

- [Kinetic of Biogas Production in Co-Digestion of Vegetable Waste, Horse Dung, and Sludge by Batch Reactors](#)
P V Dinh, T Fujiwara, S T Pham Phu et al.
- [State Equation Determination of Cow Dung Biogas](#)
A Marzuki and L B Wicaksono
- [Performance and Analysis of Floating dome Anaerobic Digester with Wet and Dry Feedstock](#)
S. Sathish, A. Parthiban, S. Venugopal et al.

Anaerobic Co-digestion of Cow Dung and Rice Straw to Produce Biogas using Semi-Continuous Flow Digester: Effect of Urea Addition

A Haryanto¹, B P Sugara¹, M Telaumbanua¹ and R A B Rosadi¹

¹ Agricultural Engineering Department, Faculty of Agriculture, The University of Lampung. Soemantri Brojonegoro Road, Bandar Lampung, Indonesia

E-mail: agus.haryanto@fp.unila.ac.id

Abstract. The objective this research was to investigate the effect of urea addition on the biogas yield from co-digestion of rice straw and cow dung using semi-continuous anaerobic digester. The experiment was conducted by using self-made semi-continuous anaerobic digester having a working volume of 30 L. Cow dung was provided from Department of Animal Husbandry, University of Lampung; while rice straw was collected from farmer at Way Galih, Tanjung Bintang, South Lampung. Rice straw was sun-dried to about 12% of moisture content and then ground into fine particles. Cow dung and ground straw were mixed at a dung-to-straw ratio of 3:1 based on total solid (TS) and four different urea additions (0, 0.25, 0.65, and 1.30 g/L) were applied to have a C/N ratio between 20 and 30. The mixture was diluted with water to create TS content of 10%. As much as 30 L of the substrate mixture was introduced into the digester as a starting load. The same substrate was added daily at a loading rate of 0.5 L/d. The experiment was made in triplicate and observation was performed for two months. Total and volatile solids of influent and effluent and daily biogas production were observed. The biogas quality was measured by its methane content using gas chromatography. Results showed that urea addition influenced the biogas yield and its quality. Substrate mixture with urea addition of 0.25 g/L (C/N ratio of 27.3) was the best in terms of biogas yield (434.2 L/kgVSr), methane content (50.12%), and methane yield (217.6 L/kgVSr).

1. Introduction

Biogas is produced through anaerobic digestion process of organic substances. The biogas is mainly composed of CH₄ (45-70%) and CO₂ (30-45%) and traces of H₂, water vapor (H₂O), ammonia (NH₃), and hydrogen sulfide (H₂S) [1, 2]. Biogas can be used to fuel several applications, from cooking stove to generating electricity. Biogas technology is now an ecologically sound option to reduce environmental burden by decomposing organic material and producing not only energy but also good quality organic fertilizer [3, 4]. Application of small biogas digester provides economic and environmental benefits to the society [5]. Biogas is one of renewable fuel that can be an important source of Indonesia's energy in the near future. This is accentuated by a fact that Indonesia is bestowed with enormous biomass both fresh matters and as wastes from agro-industrial processing. During biogas process, which is carried out under anaerobic conditions, volatile solids are decomposed and converted into methane and carbon dioxide.

Rice straw can be a promising substrate for biogas production. Straw is produced during paddy harvesting. In the past time, when paddy was harvested manually simple cutter and then sickle, straw



is left on the plant. Nowadays, rice straw is separated from the grains after the plants are threshed either manually or using stationary threshers. Recently, mechanical harvesting is conducted by using combine harvesters that is facilitated with the threshing unit so that straw is produced just after harvesting. According to IRRI, the amount of straw is roughly 0.7–1.4 kg for every kg of milled rice, depending on varieties, cutting-height of the stubbles, and moisture content during harvest [6]. As one of the largest rice producing countries in the world, Indonesia has abundant rice straw. The potential of rice straw in Indonesia in 2012 was about 91.753 million tons which is equivalent to approximately 50.974 million tons of coal with potential energy around 382,305 GWh of electricity, and the electric power potential around 43,642 MW [7]. According to the report of the Agriculture Ministry of Indonesia, about 79.4 million tons of milled rice is produced in 2016 [8]. It can be calculated that Indonesian rice straw is 49.63–99.26 million ton. It is an abundant waste that can be used to generate energy to substitute fossil fuels [7, 9].

The most common utilization of rice straw in Indonesia is for animal feed, either directly or after fermentation, even though it is classified as a poor feed for the animals due to high silica content [10]. Rice straw is also used for fuel in brick, roof tile, and pottery industries. The very little amount is used for cooking fuels. Significant amounts, however, remain unused in the fields. One common managing practice of is incorporating the rice straw into the soil during plowing to decompose and provide fertilizer for the next crop. Buresh and Sayre, however, noted that incorporation of rice straw in the soil may have detrimental effects because of the initial immobilization of soil N, decreasing Zn availability, and increasing methane emission [11]. This practice is supposed to reduce harvesting yields due to foliage diseases [12].

Another common practice is barely burning *in-situ* the straw on the fields. One of the widely accepted reasons of burning rice straw in the field is to accelerate soil preparation and to provide minerals. Research indicates, however, that open burning has negative effects such as nutrient loss, removal of soil organic matter, and reduction of beneficial soil insects and microorganisms [10]. Open burning has also been observed to contribute to emissions of harmful air pollutants. During uncontrolled burning, pollutants such as CO₂, nitrous oxide (N₂O), CH₄, CO, non-methane hydrocarbons, NO_x, SO₂, and particulate matter are emitted [13]. This emission not only does pollute the environment but also causes serious impacts on human health due to polycyclic aromatic hydrocarbons [14] which have significant toxicological properties and are notably potential carcinogens. In addition, open burning of rice straw also threatens security problems of fire disasters [15].

Anaerobic co-digestion of animal manure and agricultural byproducts has drawn increased attention [16]. Studies on biogas production by co-digestion of animal wastes with rice straw have attracted special interest. Biogas production has shown to be one of the key technologies for sustainable utilization of rice straw as renewable energy source [15]. Rice straw has such high organic matter with cellulose content of 25.4–35.5%, hemicelluloses of 32.3–37.1%, and lignin of 6.4–10.4% [17].

Rice straw is potential for biogas production because of high organic matter. The problems encountered in biogasification of rice straw are mainly related with high C/N ratio or low hydrolysis performance and digestibility because of high lignin content and its complex, stable and recalcitrant lignocellulosic structure [18], which needs a further balance of nutrients and destructive pretreatments if rice straw is used as substrate for biogasification [17, 19]. The objective of our research is to evaluate the effect of urea addition on biogas yield resulted from anaerobic co-digestion of cow dung and rice straw using semi continuous digester.

2. Materials and method

2.1. Digester preparation

Biogas production was carried out using semi-continuous anaerobic digester. The digester vessels were made of two 5-gallon drinking water containers as depicted in figure 1. The two containers were

cut at their bottom and then combined by using fiber resin and let to dry for 24 hours. A hole was made on the digester to deliver biogas into a storage balloon trough a plastic tube. The tube was facilitated with a stop valve to close the piping for biogas volume measurement and biogas sampling.

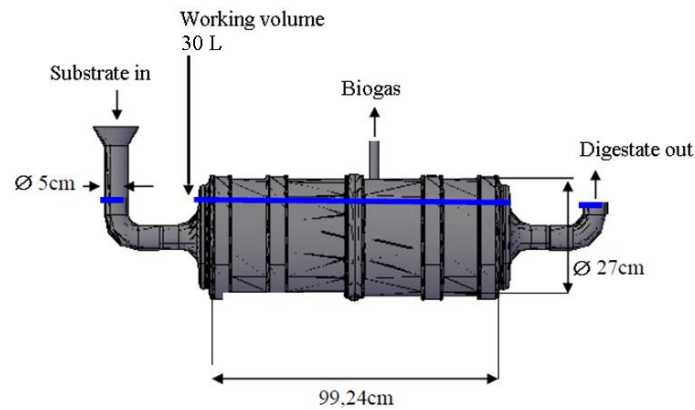

Figure 1. A self-designed semi-continuous digester prepared for the experiment

2.2. Substrate Preparation

Fresh cow dung, taken from the Department of Animal Husbandry, the University of Lampung, was used as a microbial seed source. Rice straw (figure 2) was of Ciherang variety and was collected from farmer field in Way Galih, Tanjung Bintang, Regency of South Lampung. Straw was sundried until its moisture content is about 12% (wet basis). The dried straw was chopped and ground to fine particles. Biomass size reduction is important to enhance biogas production [20]. Samples of straw and cow dung were analyzed for total solids (TS), volatile solids (VS), and carbon (C) and nitrogen (N) contents. Table 1 shows characteristics of each substrate. Urea granule with a nitrogen content of 46% was purchased from a local supplier and was used as external nitrogen source.



Figure 2. Rice straw: sun dried (left) and ground (right)

Table 1. Fresh substrate characteristic

Characteristic	Cow dung	Rice straw
Water content (% , wet basis)	71.0	11.0
Total solid (TS) (% , wet basis)	29.0	89.0
Ash (% TS)	25.04	28.48
Volatile solid (VS) (% TS)	74.96	71.52
C (%)	39.87	38.55
N (%)	1.42	0.58
C/N Ratio	28.08	66.46

2.3. Treatments and Loading

Anaerobic digesters can be classified into mainly three types based on the feeding strategy, namely batch, semi-continuous and continuous modes. In the semi-continuous system, the digester is periodically loaded with substrate according to a specific rate [21]. Most family scale biogas digesters installed in Indonesia use cow dung as substrate with semi-continuous loading mode.

The experiment was designed with TS content of about 10% of substrate mixture and TS ratio of 1:3 (straw:dung). With digester working volume of 30 L, and referring to table 1, then the composition of substrate for each digester is equivalent to 8.03 kg cow dung, 0.83 kg ground straw, and 21.10 L tap water. Initially, fine straw and cow dung were thoroughly mixed. Rice straw has so high C:N ratio that external nitrogen such as urea is required [22]. For this experiment, we prepared four level of urea addition, namely 0 (P1), 0.25 g/L (P2), 0.65 g/L (P3), and 1.3 g/L (P4). Table 2 shows substrate compositions along with their TS, VS, and C/N ratios. The experiment was conducted with three replications and 12 digesters were prepared.

Table 2. Treatment and substrate composition

Characteristic	P1	P2	P3	P4
Water content (% , wet basis)	89.48	89.49	89.51	89.50
Total solid (TS) (% , wet basis)	10.52	10.51	10.49	10.50
Ash (% TS)	25.66	25.69	25.70	25.61
Volatile solid (VS) (% TS)	74.34	74.31	74.30	74.39
C (%)*	39.75	39.75	39.75	39.75
N (%)*	1.34	1.59	1.98	2.64
C/N ratio*	30	27.3	24.3	20.5

*) Calculated based on Equation (4)

2.4. Analysis and Calculations

For determining the total solid (TS), a sample with a certain weight (W_1) was placed in ceramic vessels and dried in an oven (Memmert, type UM 500, Germany) at 105°C for 24 hours until constant weight. After cooling in the desiccator, the sample was weighed (W_2) for TS measurement. A part of this sample (W_3) was taken and burnt in a furnace (Barnstead International model FB1310M-33, USA) at 550°C for 3 hours for volatile solids (VS) determination. Five samples were taken for both fresh and spent substrate with an interval of one week. The average values were compared.

Total solid and VS are calculated by using equation (1) and (2), respectively:

$$TS (\%, wb) = \frac{W_2}{W_1} \times 100 \quad (1)$$

$$VS (\% TS) = \frac{W_3 - \text{Ash}}{W_3} \times 100 \quad (2)$$

In order to evaluate the digester efficiency, the destroyed or removed VS (VS_r) was calculated using equation developed by Koch [23]:

$$VS_r (\%) = \left[1 - \frac{VS_{out}(1 - VS_{in})}{VS_{in}(1 - VS_{out})} \right] \times 100 \quad (3)$$

where VS_{in} and VS_{out} refer to VS of fresh substrate (input) and spent substrate (output), respectively.

Carbon and nitrogen contents of each substrate were measured using element analyzer (Elementar Vario EL Cube, Germany). Carbon to nitrogen (C:N) ratio of the mixture is calculated using equation (4):

$$C : N = \frac{(C_c \times m_c) + (C_s \times m_s)}{(N_c \times m_c) + (N_s \times m_s) + 0.46 \times m_{Urea}} \quad (4)$$

where m is dry mass and subscripts c and s denote for cow dung and rice straw, respectively.

To evaluate process condition, temperature and pH of the substrate during the experiment were also checked daily. The temperature was monitored using a thermocouple inserted into the digester. The thermocouple tip was positioned around the center of digester as seen in figure 1. pH values were determined using pH meter (PHMETER, PH_009(I), China). The pH of fresh substrate was measured before its loading into the digester, while pH of spent substrate was measured just after it exits from the outlet of the digester.

Biogas production was determined using simple water displacement method. Initially biogas quality was simply observed daily by burning the biogas in a simple burner. If the biogas can be burnt it means that biogas contains enough methane. Around two weeks since the biogas can be burnt for the first time, the biogas is assumed to have a stable composition. At this time, the biogas was sampled using sampling bag to be analyzed its composition. The analysis was performed using gas chromatograph (Shimadzu GC 2014, Japan) with thermal conductivity detector (TCD), 4-m length of shin-carbon column, and Helium gas as carrier gas with flow rate 40 ml/min. Biogas yield (BY) was calculated from biogas production (BP) and VS_r :

$$BY = BP / VS_r \quad (L/kg \text{ VS}_r) \quad (5)$$

3. Results and discussion

3.1. ANOVA test

Table 3 showed results from ANOVA test for some parameters to evaluate digester performance, including average pH, average temperature, total biogas yield, average daily biogas yield, and day at which biogas can be burnt for the first time. The explanation for each variable is incorporated in the following discussion.

Table 3. Summary of ANOVA test for six parameters to evaluate digester performance^{*)}.

Treatment	Average pH	Average T (°C)	Outlet VS (% TS)	Total Biogas (L)	Daily Biogas (L)	Day Biogas Burnt ^{**)}
P1	6.81 a	30.56 a	67.5 d	259.1 b	4.3 b	23.0 b
P2	6.84 a	30.42 a	67.1 c	297.0 c	5.0 c	15.3 a
P3	6.86 a	30.62 a	64.9 a	288.1 c	4.8 c	18.3 ab
P4	6.77 a	30.29 a	68.2 b	198.4 a	3.3 a	31.3 c

Note: ^{*)} numbers followed by the same letter in the same column is not significantly different at $\alpha = 5\%$

^{**)} day at which the biogas can be burnt for the first time.

3.2. Operation condition

Temperature and pH are among the important factors influencing digester performance. Figure 3 presents daily pH values of substrate from all treatments. Abbasi *et al.* [1] noted that optimum pH range for anaerobic degradation processes satisfying the requirement for both activities and cell growth of anaerobic microorganisms is 5.5–8.5. In our experiments, digesters for co-digestion of cow dung and rice straw have initially basic pH value of 8.1 (P2 and P4) and 8.2 (P1 and P3). This actually was in the good range for anaerobic digestion process. During the first week, the pH decreased to a value of 6.5. In the second week the pH still fluctuated from around 6.5 to 7.0. Starting from the end of week two, the pH was practically stable between 6.7 and 7.0 with average value of 6.7 for P4 and 6.8 for the others. As presented in table 3, there was no significant difference on average pH value of all treatments. According to de Mes *et al.*, methanogenesis proceeds when the pH is close to neutral, and outside pH values of 6.5–7.5, the rate of methane production is low [24].

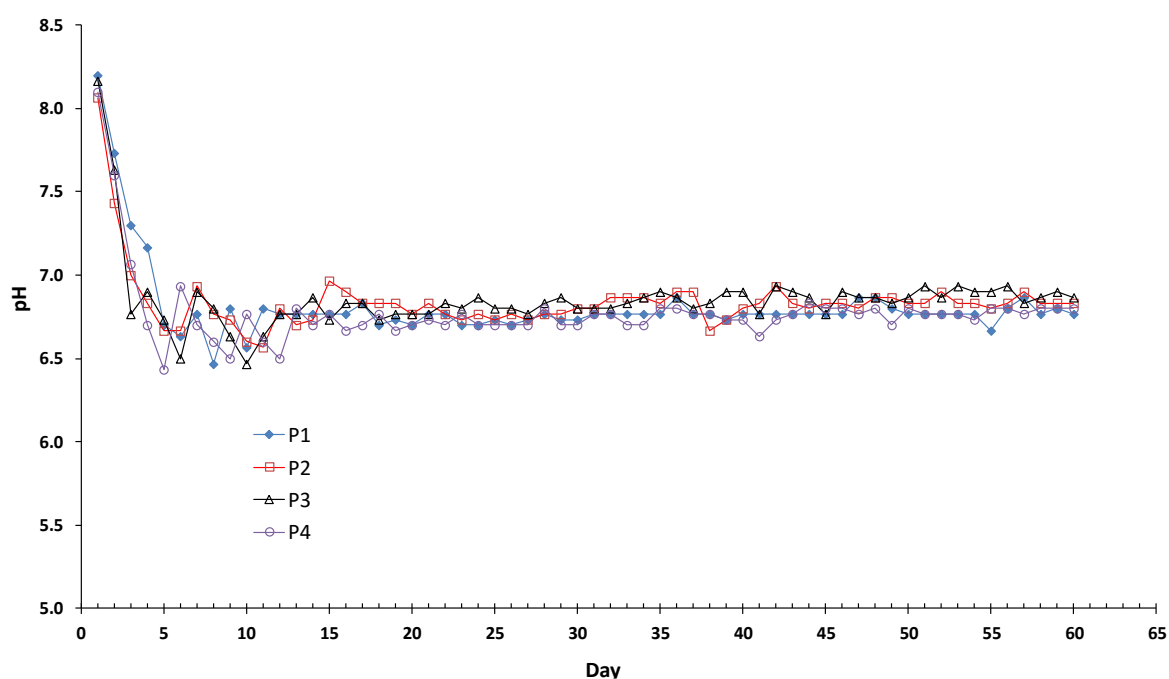

Figure 3. Change of daily pH of the substrate for different treatments

Figure 4 showed daily temperature of the digesters. All digesters operated in the mesophilic temperature region with average value of 30.56°C (P1), 30.42°C (P2), 30.62°C (P3), and 30.29°C (P4). It appears that the operating temperature of all digesters is very close to each other. There was no statistical difference of average daily temperature between all treatments. Daily temperatures for all digesters had a pattern similar to ambient temperature. This indicates that the digester temperature is strongly influenced by environmental conditions. In general, all digesters work at temperatures slightly higher than ambient temperatures (28.61°C). This is understandable because the overall reaction to the biogas process is a slightly exothermic, that is, producing heat [24].

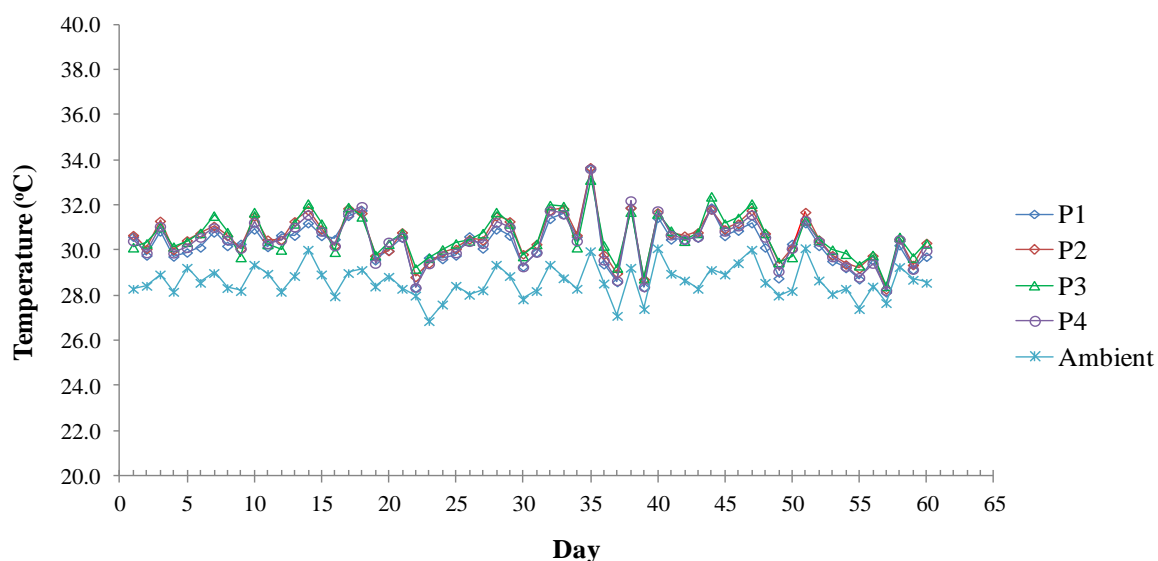

Figure 4. Comparison of daily digester temperature and ambient air.

Figure 5 shows that the digester temperature changed with time. During noon and afternoon, the digester temperature was higher than the temperature in the morning. The same was also observed for ambient temperature. It strengthens that the working temperature of the digester is greatly influenced by the ambient temperature.

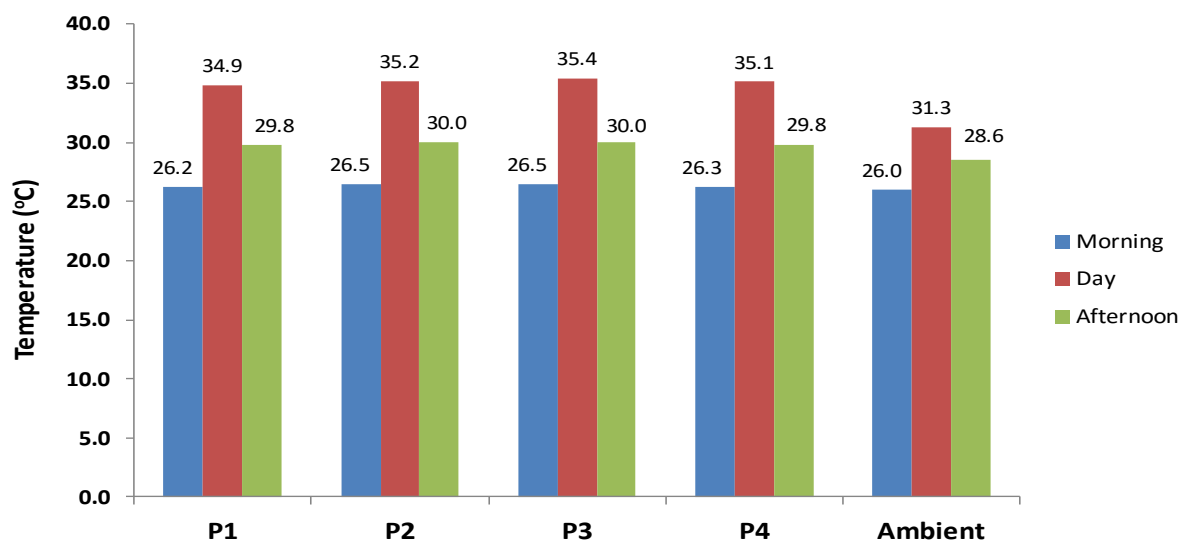

Figure 5. Average working temperature of digesters and ambient air: morning, noon, and afternoon

During anaerobic digestion process, substrate decomposition occurs. Table 4 presents characteristics of spent substrates for each treatment. The table also includes VS removal that is calculated from equation (3) and biogas yield calculated from equation (5). The addition of urea has resulted in significant difference on VS_{out} as well as VS removal. Organic material degradation (presented by VS removal) increased with increasing urea addition and achieved the highest (36% or 14 g VS/d) at urea addition of 0.65 g/L (treatment P3), and then decreased with more increase in urea addition. Recently, family size digesters using cow dung substrate have been reported to have average organic material removal of 51.32% [5]. This means that VS removal from current experiment is

significantly lower than that of actual field practices. The addition of rice straw could be responsible for this low degradation of organic matter. Therefore, other pretreatments should be applied to the straw prior to use for biogas substrate.

Table 4. Average volatile solid (VS) removal

Treatment	VS_{in} (%, TS)	VS_{out} (%, TS)	VS_r (%)	VS_r (gVS)	BY (L/kgVSr)
P1	74.34	67.5	28	11.1	388.4
P2	74.31	67.1	29	11.5	434.2
P3	74.30	64.9	36	14.0	341.7
P4	74.39	68.2	26	10.2	322.9

Note: VS values are average of five measurements.

3.3. Biogas production

Figure 6 presents daily biogas production resulted from different treatments. During the first week, the digesters showed decreasing trend of biogas production. Initially, gas was produced from respiration of the substrates due to the existence of air filling void space in the digester. Starting day 6th digester with 0.65 g/L urea addition showed increase in biogas production; while other treatments practically start to increase by day 9th. As presented in table 3, addition of urea had significantly influenced average daily biogas production. Treatment with urea addition 0.25 and 0.65 g/L produced the highest daily biogas production (5.0 L/d for P2 and 4.8 L/d for P3) compared to those of other treatments. Table 3 also confirms that amount of urea addition affects biogas quality. Initially biogas is not able to be combusted for all treatments, indicating that biogas quality is still very poor (low methane content). Slowly, the quality increases and eventually the biogas containing high enough methane so that it can be burnt. The day at which biogas can be burnt for the first time is significantly affected by amount of urea addition with P2 treatment shows the fastest (day 15) followed by P3 (day 18), P1 (day 23), and P4 (day 31). Table 4 shows that P2 produced the highest biogas yield in term of biogas production per unit of degraded organic material (434.2 L/gVSr.d). This further strengthens that the addition of urea of 0.25 g/L is the best treatment for biogas production from a mixture of cow dung with rice straw.

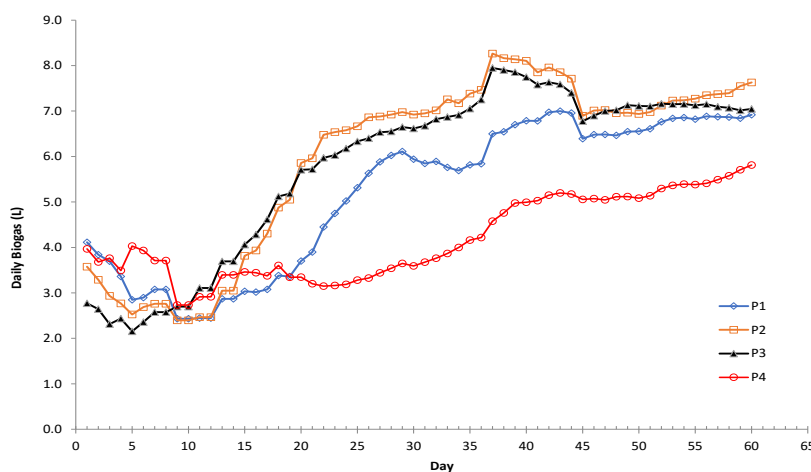

Figure 6. Daily biogas production from different treatments using 8-day moving average

Figure 7 presents cumulative biogas production. During the first three weeks, all digesters showed comparable cumulative biogas production. After that, the effect of urea addition appeared more clearly. Treatments P2 and P3 lead the biogas production with a total production of 297.0 L and 288.1 L. Addition more urea resulted in detrimental effect on biogas production. Treatment P4 with 1.3 g/L

urea addition produced the lowest biogas production (198.4 L) with daily average of 3.3 L. This correlates to low C/N ratio (20.5) and the low VS removal (26%).

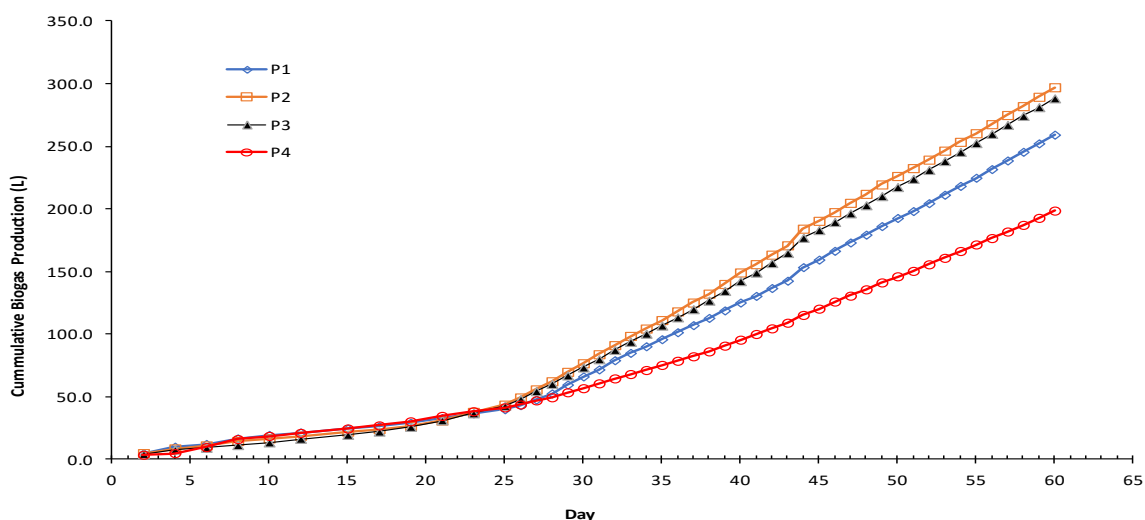

Figure 7. Cumulative biogas production from different treatments.

3.4. Methane yield

Table 5 presented biogas composition from different treatments. The methane content of P2 (urea addition 0.25 g/L) was the highest. Increasing more urea addition resulted in lower methane content. Treatment P4 with urea addition of 1.3 g/L produced biogas with lowest methane content (37.04%). Based on this composition we have calculated methane yield that was also presented in table 4 (last column). It is obvious that treatment P2 with urea addition of 0.25 g/L gave the highest methane yield; whilst P4 with urea addition of 1.3 g/L produced the lowest methane yield. Table 6 compares methane yield of our work with the values already reported by other research. Our work is a half of the maximum value reported by Lei *et al.* (2010) [25]. This meant that there is possibilities to increase methane (biogas yield) by, for example adding other pretreatments.

Table 5. Biogas composition (%) and methane yield (L/kg VSr)

Treatment	CH ₄	CO ₂	N ₂	CH ₄ Yield
P1	49.82	40.43	9.75	193.5
P2	50.12	39.97	9.91	217.6
P3	46.49	43.15	10.36	158.9
P4	37.04	35.45	27.56	119.6

Note: Biogas composition was measured around two weeks after the biogas can be burnt for the first time.

Table 6. Comparison of methane yield (L/kgVSr)

Condition	CH ₄ Yield	Reference
Cow dung 3: Straw 1, TS 10%, Urea 0.25 g/L; 30.6°C	217.6	This work
Batch, 37°C; hydrothermal pretreatment 5% NaOH	132.7	Chandra <i>et.al.</i> (2010) [26]
Phosphate addition 115 mg/L; 25°C	440.0	Lei <i>et al.</i> (2012) [25]
Batch, kitchen waste : pig manure : straw = (0.4) : (1.6) : (1); 37°C	383.9	Ye <i>et.al.</i> (2013) [27]
Straw 10 mm, preheat 110°C, ammonia 2%; 35°C	247.2	Zhang & Zhang (1999) [28]

4. Conclusions

Rice straw is promising for biogas co-substrate. The addition of rice straw as co-substrate potentially improve total biogas yield. Urea addition influenced biogas production and biogas quality from co-digestion of rice straw and cow dung using semi-continuous digester. Substrate mixture with urea addition of 0.25 g/L at which C/N ratio is 27.3 was the best treatment in terms of biogas yield (434.2 L/kg VSr/d), day at which the biogas can burnt for the first time (day 15), as well as its methane content (50.12%) and methane yield (217.6 L/kg VSr/d).

Acknowledgement

This work was financially supported by DGHE (Directorate General of Higher Education), Ministry of National Education though Strategis Nasional (STRANAS) research scheme. Contract number: 071/SP2H/LT/DRPM/IV/2017585.

References

- [1] Abbasi T, Tauseef S M and Abbasi S A 2012 *Biogas Energy* (New York: Springer) pp 1–10
- [2] Gomez C D C 2013 Biogas as an energy option: an overview *The Biogas Handbook: Science, Production and Applications*, ed A Wellinger *et al.* (Cambridge: Woodhead Publishing Limited) pp 1–16
- [3] Higgins K T 2008 Anaerobic gas and cash *Food Engineering* **80**(4) 119–20
- [4] Petis M 2006 Anaerobic digestion plant yields nutrients and power *BioCycle* **47**(12) 61–62
- [5] Haryanto A, Cahyani D, Triyono S, Murdapa F and Haryono D 2017 Economic benefit and greenhouse gas emission reduction potential of a family-scale cow dung anaerobic biogas digester *Int. Journal of Renewable Energy Development* **6**(1) 29–36
- [6] IRRI (International Rice Research Institute) 2017 Rice Straw. <http://ricestraw.irri.org/> (October 29, 2017)
- [7] Makhrani 2014 Potential analysis of rice straw as an alternative energy source for substitute coal in Indonesia *Applied Mechanics and Materials* **554** 276-280
- [8] Sulaiman A A, Simatupang P, Las I, Jamal E, Hermanto, Kariyasa I K, Syahyuti, Sumaryanto S, Suwandi and Subagyono K 2017 Success Self-Sufficiency: Indonesia Becomes a World Food Baron 2045(in Indonesian) (Jakarta: Ministry of Agriculture)
- [9] Sidjabat O 2011 Prospect of rice straw potential for bioenergy in indonesia as substituted gasoline and reducing of environmental problem *Ketenagalistrikan dan Energi Terbarukan* **10**(2) 113-122
- [10] Mandal K G, Misra A K, Hati K M, Bandyopadhyay K K, Ghosh P K and Mohanty M 2004 Rice residue- management options and effects on soil properties and crop productivity *Food, Agriculture & Environment* **2**(1) 224-231
- [11] Buresh R and Sayre K. 2007. Implications of straw removal on soil fertility and sustainability *Expert Consultation on Biofuels* (Los Banos: IRRI) p 34
- [12] Zhang R and Zhang Z 1999 Biogasification of rice straw with an anaerobic-phased solids digester system *Bioresource Technology* **68** 235–245
- [13] Gadde B, Menke C and Wassmann R 2009 Rice straw as a renewable energy source in India, Thailand, and the Philippines: Overall potential and limitations for energy contribution and greenhouse gas mitigation *Biomass and Bioenergy* **33** 1532–46
- [14] Korenaga T, Liu X and Huang Z 2001 The influence of moisture content on polycyclic aromatic hydrocarbons emission during rice straw burning *Chemosphere - Global Change Science* **3**(1) 117-122
- [15] Lei Z, Chen J, Zhang Z and Sugiura N 2010 Methane production from rice straw with acclimated anaerobic sludge: Effect of phosphate supplementation *Bioresource Technology* **101** 4343–48
- [16] Song Z, Yang G, Han X, Feng Y and Ren G 2013 Optimization of the alkaline pretreatment of rice straw for enhanced methane yield. *BioMed Research International* 1-9

- [17] Jin S and Chen H 2006 Structural properties and enzymatic hydrolysis of rice straw *Process Biochemistry* **41** 1261–64
- [18] Chen Y, Cheng J J and Creamer K S 2008 Inhibition of anaerobic digestion process: A review *Bioresource Technology* **99** 4044–64
- [19] Ward A J, Hobbs P J, Holliman P J and Jones D L 2008 Optimisation of the anaerobic digestion of agricultural resources *Bioresource Technology* **99** 7928–40
- [20] Kratky L and Jirout T 2011 Biomass size reduction machines for enhancing biogas production *Chemical Engineering & Technology* **34**(3) 391–399
- [21] Aboudi K, Álvarez-Gallego C J and Romero-García L I 2015 Semi-continuous anaerobic of sugar beet byproduct and pig manure: Effect of the organic loading rate (OLR) on process performance *Bioresource Technology* **194** 283–290
- [22] Malik R K, Singh R and Tauro P 1987 Effect of inorganic nitrogen supplementation on biogas production *Biological Wastes* **21** 139–142
- [23] Koch K 2015 Calculating the degree of degradation of the volatile solids in continuously operated bioreactors *Biomass & Bioenergy* **74** 79–83
- [24] de Mes T Z D, Stams A J M, Reith J H and Zeeman G 2003 Methane production by anaerobic digestion of wastewater and solid wastes *Bio-methane & Bio-hydrogen: Status and Perspectives of Biological Methane and Hydrogen Production* (Dutch: Dutch Biological Hydrogen Foundation)
- [25] Lei Z, Chen J, Zhang Z and Sugiura N 2010 Methane Production from Rice straw with acclimated anaerobic sludge: Effect of phosphate supplementation *Bioresource Technology* **101** 4343–48
- [26] Chandra R, Takeuchi H and Hasegawa T 2012 Hydrothermal pretreatment of rice straw biomass: A potential and promising method for enhanced methane production *Applied Energy* **94** 129–140
- [27] Ye J, Li D, Sun Y, Wang G, Yuan Z, Zhen F and Wang Y 2013 Improve biogas production from rice straw by co-digestion with kitchen waste and pig manure *Waste Management* **33** 2653–58
- [28] Zhang R and Zhang Z 1999 Biogasification of rice straw with an aerobic-phased solids digester system *Bioresource Technology* **68** 235–245