

ISBN : 978-1-4799-64314



2014

The 1st International Conference
on Information Technology,
Computer, and Electrical Engineering

ICITACEE

Semarang, 8-9 November 2014

PROCEEDINGS

*Green Technology and its Applications
for a Better Future*



UNDIP | UNIVERSITAS
DIPONEGORO
becomes an excellent research university



IEEE



Kyutech
Kyushu Institute of Technology

Proceedings

2014 1st International Conference on Information Technology, Computer and Electrical Engineering (ICITACEE)

Copyright and Reprint Permission: Abstracting is permitted with credit to the source. Libraries are permitted to photocopy beyond the limit of U.S. copyright law for private use of patrons those articles in this volume that carry a code at the bottom of the first page, provided the per-copy fee indicated in the code is paid through Copyright Clearance Center, 222 Rosewood Drive, Danvers, MA 01923. For reprint or republication permission, email to IEEE Copyrights Manager at pubs-permissions@ieee.org. All rights reserved.

Copyright ©2014 by IEEE.

Publisher :

Department of Electrical Engineering
Diponegoro University

ISBN : 978-1-4799-6431-4 (PRINT, Part Number : CFP1489Z-PRT)

ISBN : 978-1-4799-6430-7 (CD-ROM Part Number : CFP1489Z-CDR)

ISBN : 978-1-4799-6432-1 (XPLORE COMPLIANT, Part Number : CFP1489Z-ART)

Additional copies may be ordered to:
Department of Electrical Engineering
Diponegoro University,
Jl. Prof. H. Soedarto, S.H., Tembalang
Semarang, Indonesia 50275

GREETINGS FROM THE GENERAL CHAIR

Welcome to 2014 1st International Conference on Information Technology, Computer, And Electrical Engineering (ICITACEE) held in Semarang, the capital city of Central Java! This conference provides a forum for researchers, academicians, professionals, and students from various engineering backgrounds and also from cross-disciplinary research in the development and the design of Information Technology & Computer, Power System, Circuit & Control, and Communication Systems, as well as the Interdisciplinary topics to interact and to disseminate the latest issues and research.

The ICITACEE 2014 is held in the ICT building of Diponegoro University on November, 8. Three distinguished scholars will start the session as keynote speakers: Prof. Hiroshi Ochi as a wireless expert from Kyushu Institute of Technology Japan, Dr. Trio Adiono as an IC design expert from Bandung Institute of Technology, and Mr. Adi Rahman Adiwoso as an aeronautics expert from PT Pasific Satellite Nusantara. We are very grateful for them to share their knowledge, experience, and their motivation for always doing the best. We recently received more than 140 papers, however only of 87 high quality papers were accepted and being presented in this event. All the accepted and presented papers will be then published in the IEEE Xplore (ISBN 978-1-4799-6432-1). We will select the best papers of each categories mentioned above.

Organizing such an ambitious conference has always been incredibly challenging and would have been impossible to happen without our outstanding committee supports. I would like to thanks all staffs of Department of Electrical Engineering and Department of Computer System as well as IEEE Student Branch of Diponegoro University. They have been working very hard and been always providing me with unprecedented support, advice, and kind assistance on all aspects of the conference. Special thanks goes to the IEEE Indonesia Section, Cisco, Des Net, and PSN for all support to ICITACEE 2014. I also would like to thank all of the steering committee, technical program committee, reviewers, authors, session organizers and chairs, and other volunteers and participants. I expect that everyone is able to enjoy some of what Semarang City has to offer! Hopefully The ICITACEE 2014 conference would become the event of our best deeds.



Wahyul Amien Syafei

General Chair,

2014 1st International Conference of Information Technology,
Computer and Electrical Engineering (ICITACEE)

FOREWORD FROM HEAD OF DEPARTMENT OF ELECTRICAL ENGINEERING, UNIVERSITAS DIPONEGORO, SEMARANG-INDONESIA

It is pleasant to welcome all the participants in the International Conference on Information Technology, Computer, and Electrical Engineering (ICITACEE 2014) at Semarang. This is the second conference held together by Electrical Engineering Department and Computer System Department of Engineering Faculty Universitas Diponegoro. I would like to welcome several keynote speakers from Kyushu Institute of Technology Japan and Institut Teknologi Bandung.

As the Chief of Electrical Engineering Department Universitas Diponegoro, I would like to appreciate the vast work in this conference as collaborative effort among Electrical Engineering Department, Computer System Department Universitas Diponegoro, IEEE Student Branch of Universitas Diponegoro and IEEE Indonesia Section. I also wish that this conference to be a needed forum for engineers and scientist to communicate and sharing their findings and precious researches.

I would like to express hearty gratitude to Organizing Committee members, staffs, and students of Electrical Engineering and Computer System Department of Universitas Diponegoro for their efforts and supports. I do expect that this conference will give important contribution to development of Electrical Engineering and Computer Science locally and internationally.



Ir. Agung Warsito. D.H.E.T

Head, Department of Electrical Engineering – Faculty of Engineering
Universitas Diponegoro, Semarang – Indonesia
and
Vice Chairman of FORTEI (Indonesia Electrical Engineering Forum)

FOREWORD FROM DEAN OF FACULTY OF ENGINEERING UNIVERSITAS DIPONEGORO, SEMARANG – INDONESIA

The International Conference on Information Technology, Computer, and Electrical Engineering (ICITACEE 2014) is now held in Semarang, Indonesia and being organized under the collaborative committee effort among Electrical Engineering and Computer System Department Diponegoro University and IEEE (Institute of Electrical and Electronics Engineers) Indonesia Section. This event also becomes a part of 56th Faculty of Engineering Dies Natalis and 57th Diponegoro University Dies Natalis agenda

The goals of the conference are to obtain and extend the knowledge of the recent issues, opinions, bright ideas about the development of a comprehensive green technology constructively from distinguish scholars, researchers, and academics. Furthermore, this forum is expected to bring new innovations in technology for a better future, especially in the field of information technology, computers, and electrical engineerings and also create cooperation between institutions of science at the college level, industries and government.

It is a great pleasure to welcome all the participants of this conference and also several keynote speakers from Kyushu Institute of Technology Japan, Bandung Institute of Technology and Pasific Satelite Nusantara.

I do hope that this conference to be a valuable forum for engineers and scientist to share their precious researches and this event will give significant contributions to the development of Electrical Engineering and Computer Science. It is hope that this conference will rise the awareness of scientific community members in bringing better life.

I hope that the conference will be stimulating and memorable for you. So, enjoy your time in Semarang.



Ir. Bambang Pudjianto, M.T.
Dean, Faculty of Engineering
Universitas Diponegoro, Semarang – Indonesia

ICITACEE COMMITTEE

General Chair : Wahyul Amien Syafei

Co- Chair : R. Rizal Isnanto

ORGANIZING COMMITTEE:

Adian Fatchur Rochim

Sukiswo

Mochammad Facta

Ajub Ajulian Zahra

Aris Triwiyatno

Eko Didik Widiyanto

Sumardi

Achmad Hidayatno

Yuli Christyono

Munawar Agus Riyadi

Dania Eridani

Darjat

STEERING COMMITTEE :

Muhammad Nuh (Indonesian Ministry of National Education)

Trio Adiono (IEEE Solid State Circuit Indonesian Chapter)

Wahyul Amien Syafei (Diponegoro University)

Hiroshi Ochi (Kyushu Institute of Technology, Japan)

Hiroshi Furukawa (Kyushu University, Japan)

Kuncoro Wastuwibowo, Ir. MSc. (IEEE Indonesian Section)

Onil Nazra Persada (France)

Mauridhi Heri Purnomo (Sepuluh November Institute of Technology)

Razali Ismail (University Teknologi Malaysia, Malaysia)

Taufik (California Polytechnic State, USA)

TECHNICAL PROGRAM COMMITTEE :

Masayuki Kurosaki (Kyushu Institute of Technology)
Eko Handoyo (Utrecht University, Netherland)
R. Rizal Isnanto (Diponegoro University)
Mochammad Facta (Diponegoro University)
Munawar Agus Riyadi (Diponegoro University) Aris
Triwiyatno (Diponegoro University)
Sidiq Syamsul H (State Polytechnics of Semarang) Trio
Adiono (Bandung Institute of Technology)
Adhi Susanto (Gadjah Mada University)
Paulus Insap Santosa(Gadjah Mada University)
Ismail Sa'ad (University Technology Malaysia) Azli
Yahya (University Technology Malaysia) Hendra
Setiawan (Indonesian Islamic University)
Slamet Riyadi (Soegijapranoto Catholic University)
Supari (Semarang University)
Onil Nazra Persada (CEA, France)
M. Hadin (Sultan Agung Islamic University)
Teguh Prakoso (Diponegoro University)
Sri Ratna Sulistiyanti (Lampung University)
Ratna Wardani (Yogyakarta State University)
Suryani Alifah (Sultan Agung Islamic University)
Florentinus Budi Setiawan (Soegijapranoto Catholic University)
Rahmat Budiarto (Al Baha University, Saudi Arabia)
Abdul Kadir (Gajah Mada University)
Junaidi (Universiti Teknologi Malaysia)
Muhammad Aziz Muslim (Brawijaya University)
Muhammad Amjad (The Islamia University of Bahawalpur, Pakistan)
Bahniman Ghosh (Indian Institute of Technology Kanpur, India)

KEYNOTE SPEAKER 1

Keynote Speech :

Prof. Hiroshi Ochi
(Kyushu Institute of Technology, JAPAN)

Keynote Title :

Multi-User MIMO Wireless System -From Theory to Chip Design

Speaker's Biography:

Hiroshi Ochi is a professor in Computer Science and Electronics of Kyushu Institute of Technology in Fukuoka, Japan. Dr. Ochi is a cofounder of Que-Wave. He received Ph.D. from Tokyo Metropolitan University in 1990. He has been engaged in researches and developments of digital communication systems and signal processing areas at an academic environment since 1986. He brings over 17 years of experience and knowledge of electronics engineering to Que-Wave. One of the reasons he founded QW is he has felt to need more useful and high-performance devices than ever. And then, he decided to focus on producing useful tools and services from an engineer's point of views.



KEYNOTE SPEAKER 2

Keynote Speech :

Prof. Dr. Trio Adiono
(Institut Teknologi Bandung)

Keynote Title :

Challenges and Opportunities in Designing Internet of Things

Speaker's Biography:

Trio Adiono is faculty member of the School of Electrical Engineering and Informatics of Institut Teknologi Bandung (ITB) and the head of IC Design Laboratory of Microelectronics Center ITB. He obtained his Ph.D. degree in VLSI Design from Tokyo Institute of Technology (Titech), Japan. From 2002 to 2004 he was a research fellow of the Japan Society for the Promotion of Science (JSPS) in Titech. In 2005, he was a visiting scholar at MESA+, Twente University, Netherlands. He has developed several microchips for video processing, smart card, NFC, and WiMax Baseband Chip. He received the "Second Japan Intellectual Property (IP) Award" in 2000 from Nikkei BP for his research on "Low Bitrate Video Communication LSI Design".



KEYNOTE SPEAKER 3	
Keynote Speech :	Adi Rahman Adiwoso (Pasifik Satelit Nusantara)
Keynote Title :	Role of Telecommunication Satellite in Indonesia
Name : Adi Rahman Adiwoso Place / Date of Birth : Yogyakarta, 26 July 1953 Status : Married With 2 Children Education : BSc in Aeronautical and Astronautical Engineering, Purdue University, 1974 MSc in Aeronautical and Astronautical Engineering, California Institute of Technology, 1976 Work Experience : 1974 – 1982 Hughes Aircraft Company 1982 – 1987 Rasikomp Nusantara 1987 – 1990 PT Rajasa Hazanah Perkasa as Managing Director 1987 – 1991 Board member and COO of Orion Satellite Asia Pacific in Washington DC 1991 – Current President Director of PT Pasifik Satelit Nusantara 1993 – 1995 Marketing Director of PT Satelit Palapa Indonesia 1994 – Current Chairman and CEO of ACeS 1999 – 2008 Chairman of Indonesian Institute of Corporate Governance 2005 – 2006 Expert Staff for BRR 2007 – 2012 Member of Board of Commissioner of PT Garuda Indonesia 2008 – 2012 Member of Board of Commissioner of PT Dirgantara Indonesia (Persero) 2008 – 2011 Member of Board of Commissioner of PT Perusahaan Pengelola Aset 2009 – 2010 Member of Board of Commissioner of PT Merpati Nusantara Other : Graduate with Honors from Purdue University Howard Hughes Fellowship Nominated in 1997 as The Best Satellite Executive of The Year, Washington DC Nominated in 2001 as The Best Satellite Executive of The Year, Washington DC Awarded in 2005 as The Best Satellite Executive of The Year in the Asia-Pacific	

2014 1st International Conference on Information Technology, Computer and Electrical Engineering (ICITACEE)

CONFERENCE PROGRAM

SATURDAY, 8 NOVEMBER 2014

7:30 - 8:00	Registration			
8:00- 8:45	Opening ceremony			
	Photo session			
8:45 - 9:00	Coffee break			
9:00 - 9:50	Invited speaker 1: Prof. Hiroshi Ochi (<i>Kyushu Institute of Technology, JAPAN</i>) <i>Multi-MIMO Wireless System - from Theory to Chip Design</i>			
9:50 - 10:40	Invited speaker 2: Prof. Dr. Trio Adiono (Institut Teknologi Bandung) <i>Challenges and Opportunities in Designing Internet of Things</i>			
10:40 - 11:30	Invited speaker 3: Dr. Adi Rahman Adiwoso (PT. Pasifik Satelit Nusantara) <i>Role of Satellite Telecommunication in Indonesia</i>			
11:30 - 12:30	LUNCH BREAK			
12:30 - 15:00	Parallel session 1			
	ROOM A	ROOM B	ROOM C	ROOM D
15:00 - 15:15	coffee break			
15:15 - 17:30	Parallel session 2			
	ROOM A	ROOM B	ROOM C	ROOM D
18:30 - 20:00	GALA DINNER			

SUNDAY, 9 NOVEMBER 2014

8:00 - ...	<i>cultural program (city tours)</i> <i>(*with additional arrangements)</i>
------------	--

PARALLEL SESSION

TIME	NO	ROOM A (HALL, 5th FLOOR)		ROOM B (5th FLOOR)		ROOM C (4th FLOOR)		ROOM D (4th FLOOR)	
		CODE	TITLE	CODE	TITLE	CODE	TITLE	CODE	TITLE
12.30 - 15.00	1	PS01	Design and Implementation of Solar Power as Battery Charger Using Incremental Conductance Current Control Method based on dsPIC30F4012	IP01	Visual Object Tracking using Particle Clustering	CC01	Enhancement of DRAMs Performance using Resonant Tunneling Diode Buffer	ITC01	The Development of 3D Educational Game to Maximize Children's Memory
	2	PS02	An Adaptive Neuro Fuzzy Inference System for Fault Detection in Transformers by Analyzing Dissolved Gases	IP02	Selective Encryption of video MPEG use RSA Algorithm	CC02	Real-time SoC Architecture and Implementation of Variable Speech PDF based Noise Cancellation System	ITC02	The Influence of Knowledge Management to Successful Collaborative Design
	3	PS03	Optimal Power Flow based upon Genetic Algorithm deploying Optimum Mutation and Elitism	IP03	Analytical Hierarchy Process for Land Suitability Analysis	CC03	Application of Supervised Learning in Grain Dryer Technology Recirculation Type Cooperated with Wireless Sensor Network	ITC03	Knowledge and Protocol on Collaborative Design Selection
	4	PS04	Design Analysis and Optimization of Ground Grid Mesh of Extra High Voltage Substation Using an Intelligent Software	IP04	Training Support for Pouring Task in Casting Process using Stereoscopic Video See-through Display - Presentation of Molten Metal Flow Simulation Based on Captured Task Motion -	CC04	Design of Real-Time Gas Monitoring System Based-on Wireless Sensor Networks for Merapi Volcano	ITC04	Mobile-Based Learning Design with Android Development Tools
	5	PS05	Design and Simulation of Neural Network Predictive Controller Pitch-Angle Permanent Magnetic Synchronous Generator Wind Turbine Variable Pitch System	IP05	Feature Extraction and Classification of Heart Sound based on Autoregressive Power Spectral Density	CC05	ANFIS Application for Calculating Inverse Kinematics of Programmable Universal Machine for Assembly (PUMA) Robot	ITC05	A mobile diabetes educational system for Fasting Type 2 Diabetes in Saudi Arabia
	6	PS06	Inverse Clarke Transformation based Control Method of a Three-Phase Inverter for PV-Grid Systems	IP06	Smart-Meter based on current transient signal signature and constructive backpropagation method	CC06	MRC NN Controller for Arm Robot Manipulator	ITC06	Aggressive Web Application Honeypot for Exposing Attacker's Identity
	7	PS07	Control of a Single Phase Boost Inverter with the Combination of Proportional Integrator and Hysteresis Controller	IP07	AUTOMATIC DOORSTOP SAFETY SYSTEM BASED ON IMAGE PROCESSING WITH WEBCAM AND SCANNER	CC07	Development of Microcontroller-based Stereoscopic Camera Rig Positioning System	ITC07	Adjustment Levels for Intelligent Tutoring System using Modified Items Response Theory
	8	PS08	A Simple Three-phase Three-wire Voltage Disturbance Compensator	IP08	Palprint Identification for User Verification based on Line Detection and Local Standard Deviation	CC08	Design of A Digital PI Controller for Room Temperature on Wireless Sensor and Actuator Network (WSAN) System	ITC08	Smile Recognition System based on Lip Corners Identification
	9	PS09	Analysis of Protection Failure Effect and Relay Coordination on Reliability Index	IP09	Cerebellar Model Articulation Controller (CMAC) for Sequential Images Coding	CC09	Display and Interface of wireless EMG measurements	ITC09	An Integrated Framework for Measuring Information System Success Considering the Impact of Culture in Indonesia
	10	PS10	Extreme Learning Machine Approach to Estimate Hourly Solar Radiation On Horizontal Surface (PV) in Surabaya - East Java	IP10	A Comparative Study on Signature Recognition	CC10	Accuracy Enhancement of Pickett Tunnelling Barrier Memristor Model	ITC10	Pre-Processing Optimization on Sound Detector Application AudiTion (Android Based Supporting Media for the Deaf)
COFFEE BREAK									
15.15 - 17.30	11	PS11	Maximum Power Point Tracking Control for Stand-Alone Photovoltaic System using Fuzzy Sliding Mode Control Maximum Power Point Tracking Control for Stand-Alone Photovoltaic System using Fuzzy Sliding Mode Control	IP11	Study of Environmental Condition Using Wavelet Decomposition Based on Infrared Image	CC11	Data Fusion and Switching Function For UAV Quadrotor Navigation System	ITC11	EVALUATION OF DISTRIBUTION NETWORK RELIABILITY INDEX USING LOOP RESTORATION SCHEME
	12	PS12	The Influence of Meteorological Parameters under Tropical Condition on Electricity Demand Characteristic: Indonesia Case Study	IP12	Very High Throughput WLAN System for Ultra HD 4K Video Streaming	CC12	Data logger Management Software Design for Maintenance and Utility in Remote	ITC12	Efficient Message Security Based Hyper Elliptic Curve Cryptosystem (HECC) for Mobile Instant Messenger
	13	PS13	Optimal Distribution Network Reconfiguration with Penetration of Distributed Energy Resources	IP13	Iris Recognition Analysis Using Biorthogonal Wavelets Transform for Feature Extraction	CC13	Investigation of Electrical Properties of Nanofibre Polyaniline Synthesize as Material for Sensor	ITC13	Application of Web-Based Information System in Production Process of Batik Industry Design Division
	14	PS14	Maximum Power Point Tracking Photovoltaic Using Root Finding Modified Bisection Algorithm	TE01	Data Rate of Connections Versus Packet Delivery of Wireless Mesh Network with Hybrid Wireless Mesh Protocol and Optimized Link State Routing Protocol	CC14	Reconfigurable Floating Point Adder	ITC14	Managing and Retrieval of Cultural Heritage Multimedia Collection Using Ontology
	15	PS15	Design of LLC Resonant Converter for Street Lamp Based On Photovoltaic Power Source	TE02	Empirical Studies of Wireless Sensor Network Energy Consumption for Designing RF Energy Harvesting	CC15	HOVER POSITION CONTROL WITH FUZZY LOGIC	ITC15	Individual Decision Model for Urban Regional Land Planning

16	PS16	Power Loss Reduction Strategy of Distribution Network with Distributed Generator Integration	TE03	Modulation Performance in Wireless Avionics Intra Communications (WAIC)	CC16	METHODOLOGY OF FUZZY LOGIC WITH MAMDANI FUZZI MODELS APPLIED TO THE MICROCONTROLLER	ITC16	Enhancing Online Expert System Consultation Service with Short Message Service Interface
17	PS17	Double Dielectric Barrier Discharge Chamber for Ozone Generation	TE04	Implementation and Performance Analysis of Alamouti Algorithm for MIMO 2 ¹ —2 Using Wireless Open-Access Research Platform (WARP)	CC17	Fall Detection System Using Accelerometer and Gyroscope Based on Smartphone	ITC17	Mobile Nutrition Recommendation System For 0-2 Year Infant
18	PS18	Leakage Current Characteristics at Different Shed of Epoxy Resin Insulator under Rain Contaminants	TE05	Period Information Deviation on the Segmental Sinusoidal Model	CC18	Design and Implementation of Sensor Fusion for Inertia Measurement on Flying Robot Case Study: Hexacopter	ITC18	Comparison of Distance and Dissimilarity Measures for Clustering Data with Mix Attribute Types
19	PS19	Transformer monitoring using harmonic current based on wavelet transformation and probabilistic neural network (PNN)	TE06	A Compact Dual-band Antenna Design using Meander-line Slots for WiMAX Application in Indonesia	CC19	Triple Band Bandpass Filter With Cascade Tri Section Stepped Impedance Resonator	ITC19	Determining E-commerce Adoption Level by SMEs in Indonesia Based on Customer-Oriented Benefits
20			TE07	Design and Analysis of Dualband J-Pole Antenna with Variation in T-Shape for Transceiver Radio Communication at VHF and UHF Band	CC20	Temperature Response Analysis Based on Pulse Width Irradiation of 2.45 GHz Microwave Hyperthermia	ITC20	Providing Information Sources Domain for Information Seeking Agent From Organizing Knowledge
21			TE08	Low Cost Implementation for Synchronization in Distributed Multi Antenna Using USRP/GNU-Radio	ITC24	Visualization of Condition Irrigation Building and Canal Using Web GIS Application	ITC21	Decision Support System For Stock Trading Using Decision Tree Technical Analysis Indicators and Its Sensitivity Profitability Analysis
22			TE09	Development of the First Indonesian S-Band Radar	ITC25	Comparison of three back-propagation architectures for interactive animal names utterance learning	ITC22	Design Web Service Academic Information System Based Multiplatform
23					ITC26	WORK IN PROGRESS - OPEN EDUCATION METRIC (OEM) : DEVELOPING WEB-BASED METRIC TO MEASURE OPEN EDUCATION SERVICES QUALITY	ITC23	Effects of VANET's Attributes on Network Performance

Study of Environmental Condition Using Wavelet Decomposition Based on Infrared Image

S. R. Sulistiyanti, M. Komarudin, L. Hakim, A. Yudamson

Department of Electrical Engineering, Faculty of Engineering

University of Lampung

Bandarlampung, Indonesia

sr_sulistiyanti@eng.unila.ac.id,

m.komarudin@eng.unila.ac.id,

plgsekip@eng.unila.ac.id,

afri.yudamson@eng.unila.ac.id

Abstract—In this paper, we report our experiment about wavelet decomposition for study environmental condition based on infrared images. Infrared images acquired by consumer digital camera, after replacing the infrared stoping filter with filter SRS, and the images captured sequentially every two hours (from 06:00—16:00). The result of this research is the increasing air pollution characterized using wavelet decomposition by increasing index value from 0—3 and amount of white spots about 60% (from 5%—65%). Finally wavelet decomposition was made to estimate the environmental condition, especially air pollution, based on infrared image.

Keywords—environmental condition, wavelet decomposition, infrared image

I. INTRODUCTION

Air as a component of the environment is important in life needs to be maintained in order to provide support for living things in an optimal. Several researchers have been working on air quality remote monitoring system researches. An Internet and short message-based air quality monitoring was developed in [1], [2]. However, to the authors' knowledge, an air quality remote monitoring system based on thermal imaging of the surrounding environment has not been developed in Indonesia. Therefore, this study proposes an air pollution monitoring system based on infrared images using wavelet decomposition.

II. THE UNDERLYING THEORY

Air pollution is harmful elements that may result in environmental damage, disruption on human health and the quality of the environment. The causes of air pollution caused by motor vehicle exhaust using gasoline and diesel as well as the disposal of the remnants of the industrial plant that could damage the environment.

Worse air environment is estimated to be the causes of fatigue during the trip. Fatigue can lead to motorists and other

road users cannot control themselves. In turn, this may reduce alertness and threaten the safety of the trip. However, there is currently no practical tools to tell this condition. So far, the road superintendents (traffic police and CCTV cameras) are only able to tell the extent of traffic levels. In fact, the more dense and the longer traffic congestion, pollution levels in the jammed area also increased. This has implications for accelerated fatigue and concentration of motorists and other road users. CCTV cameras were installed to monitor the level of traffic density and the infrared camera can be used utilized as a means of monitoring air pollution. The resulting infrared image is a picture of a record object or objects in an image is usually a picture. The term image is used to express the intensity of light in a two-dimensional function $f(x, y)$, where (x, y) coordinates of spatial states and the values of f at the point (x, y) expressed levels of brightness (gray level) image at that point [3].

A. Infrared image

Infrared image acquired from infrared photography, they have wavelength greater than 700 nm.

Investigation the characteristics of the light-absorbing filter visual and infrared light passed by the effect of variations in light intensity and SRS filter the results obtained [4]; [5] studied the physical phenomena on digital photography which in fact can be improved by using the image of near infrared (NIR), the result of a combination of NIR image with a grayscale image look more powerful than the original RGB image.

Furthermore Fredembach et al. [6] suggested that the near-infrared spectrum contains important information about the imaging light source. It is shown that a simple calculation of the ratio of the NIR and RGB, scene illuminant can be determined accurately.

Have obtained infrared image histogram characteristics are captured using a modified digital camera [7]. Furthermore

conducted a study and found that moving averages can be applied to spatial filtering towards the object to obtain thermal conditions [8]. Sulistiyanti, et. al. also found that slicing the histogram can be used to obtain information object temperature distribution thermal conditions [9]. Furthermore, by conducting research with Surface (2D) contour fittings obtained for the isothermal calorimetry catches consumer digital camera [10]. Article entitled characterization of Cutting Temperature and Ignition Phenomena of Magnesium Chip using Infrared Imaging [11] indicated that infrared thermography could be use to determine the ignition point of magnesium chips cutting temperature.

B. Wavelet Transform

The wavelet transform is processing for images, used 2-D wavelet transform. The steps of 2-D wavelet transform could be illustration in the Figure 1.

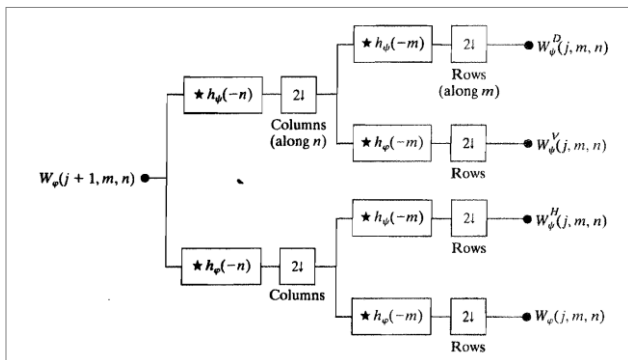

Fig. 1 The 2-D Fast Wavelet Transform, the analysis filter bank [12].

C. Wavelet Decomposition

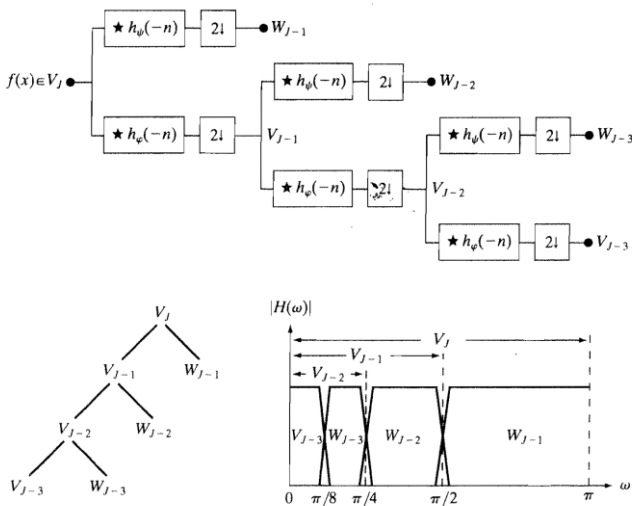

Fig. 2 A three-scale FWT filter bank: a. block diagram; b. decomposition space tree; and c. spectrum splitting characteristic [12].

In [13], demonstrate the advantage of this algorithm over standard soft thresholding (implemented with the same wavelet representation) on images with artificial Gaussian noise. On infrared images of land mines from our data set, this

simple technique offers a significant improvement. The background noise is strongly suppressed and the presence of the object of interest is enhanced. One should note that noise suppression is achieved here by a “severe” suppression of all the coefficients that are not located in the vicinity of the edges detected from the low-pass images. This is useful for images where a uniform-intensity object needs to be distinguished from a background, but this method is not as favorable in cases where fine image details need to be preserved.

III. MATERIALS AND METHODS

The experiment used Fuji Finepix A400 digital camera is given filter infrared SRS, performed around the market Bambu Kuning Bandarlampung. Data obtained starting at 06.00 s.d. 16.00, with a time interval of 2 hours. For infrared images of environmental condition processing, the RGB images converted into gray level images. Conversion to gray level meant to be seen how much noise of the object. After that, the next step is processing using wavelet transformation and wavelet decomposition method, to compare the result of them. Wavelet and wavelet decomposition process aims to evaluate concerning this for characterize air pollutant.

IV. RESULTS OF THE RESEARCH

Figure 3 shows one of original infrared environmental image with position of cropping in RGB and grayscale format, local time is 06:00. Position of cropping assumed as air condition unlimited and could be used everywhere. If cropping in the building, the result obtained in the other place must be calibrate with the building. The images, captured every two hours from 06:00 till 16:00, changed be grayscale images. After that, the grayscale images processed use wavelet and wavelet decomposition.

Figure 4 show the result of wavelet processing, they captured every two hours from 06:00 till 16:00. On the left of each image in Figure 4 is a process wavelet, top-left and clockwise are grayscale an image, horizontal process, diagonal process, and vertical process. And on the right of each image in Figure 4 is amount of horizontal, vertical, and diagonal process of wavelet decomposition. In Figure 4, increasingly air pollution depends on the time. In the morning (06:00—08:00) qualitatively resulting images seen ‘dark’, these mean environmental condition relatively clear, but from 10:00—16:00 seen increasing ‘white spots’, these mean dirty air in other words increasing pollution air. Index value in these result of wavelet decomposition processing of images also increase from 0—3 (dark or black spots=0 and white spots=3). It could be show in Figure 4. Figure 4 also show the result of wavelet decomposition processing, they captured every two hours from 06:00 until 16:00. Like Figure 3, the left of each image in Figure 4 is a process wavelet decomposition, top-left and clockwise are grayscale an image, horizontal process, diagonal process, and vertical process. And on the right of each image in Figure 4 is amount of horizontal, vertical, and diagonal process of wavelet decomposition.

Seen in Figure 5, increasingly air pollution depends on the time. In the morning (06:00—08:00) qualitatively resulting images seen ‘dark’, these mean environmental condition

relatively clear, but from 10:00—16:00 seen increasing ‘white spots’, these mean dirty air in other words increasing pollution air. Index value in these result of wavelet decomposition processing of images also increase from 0—3 (dark or black spots=0 and white spots=3) and amount of white spots

increase about 60% (from 5% become 65%), it could be show in Figure 5.

The result of this research shows that wavelet transform could be used to see environmental condition but it is less clear than wavelet decomposition. This is as seen in Figure 4 and Figure 5.



Fig. 3 One of original image

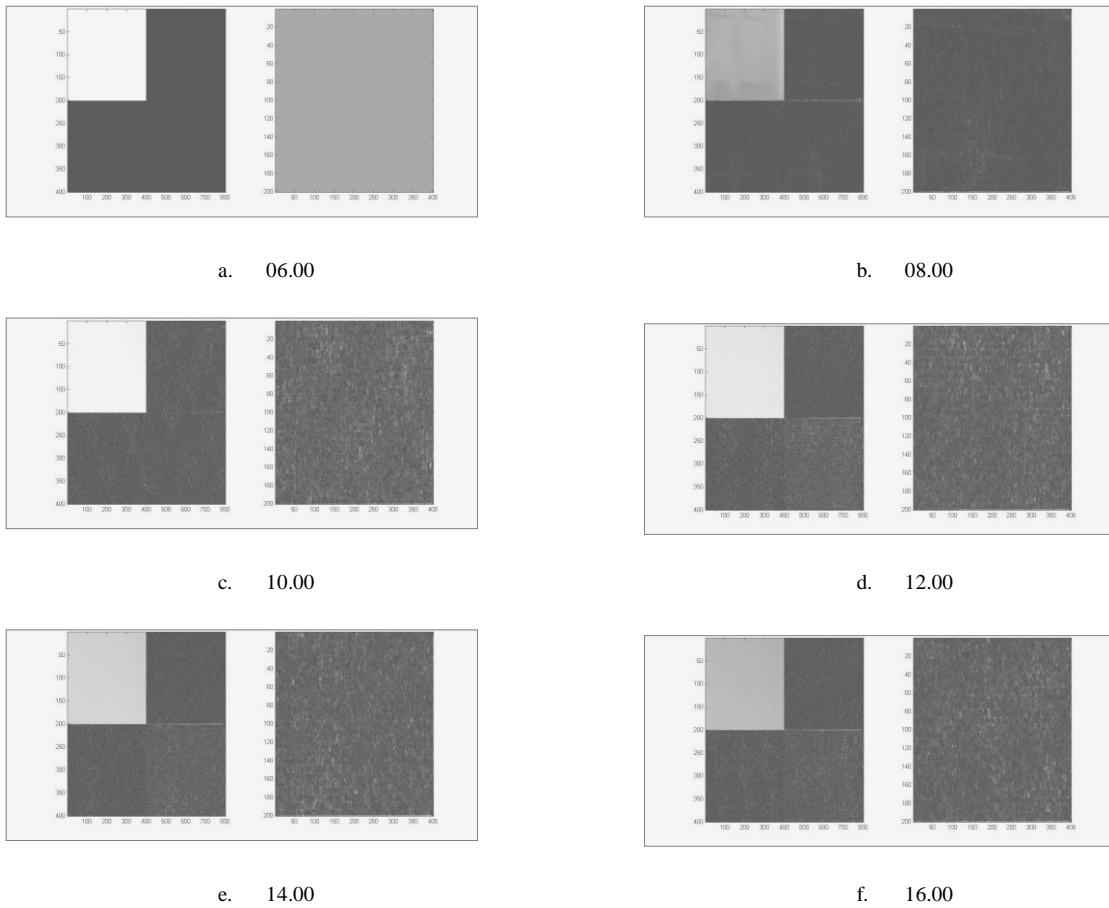

Fig. 4 Wavelet transform of infrared environmental condition images

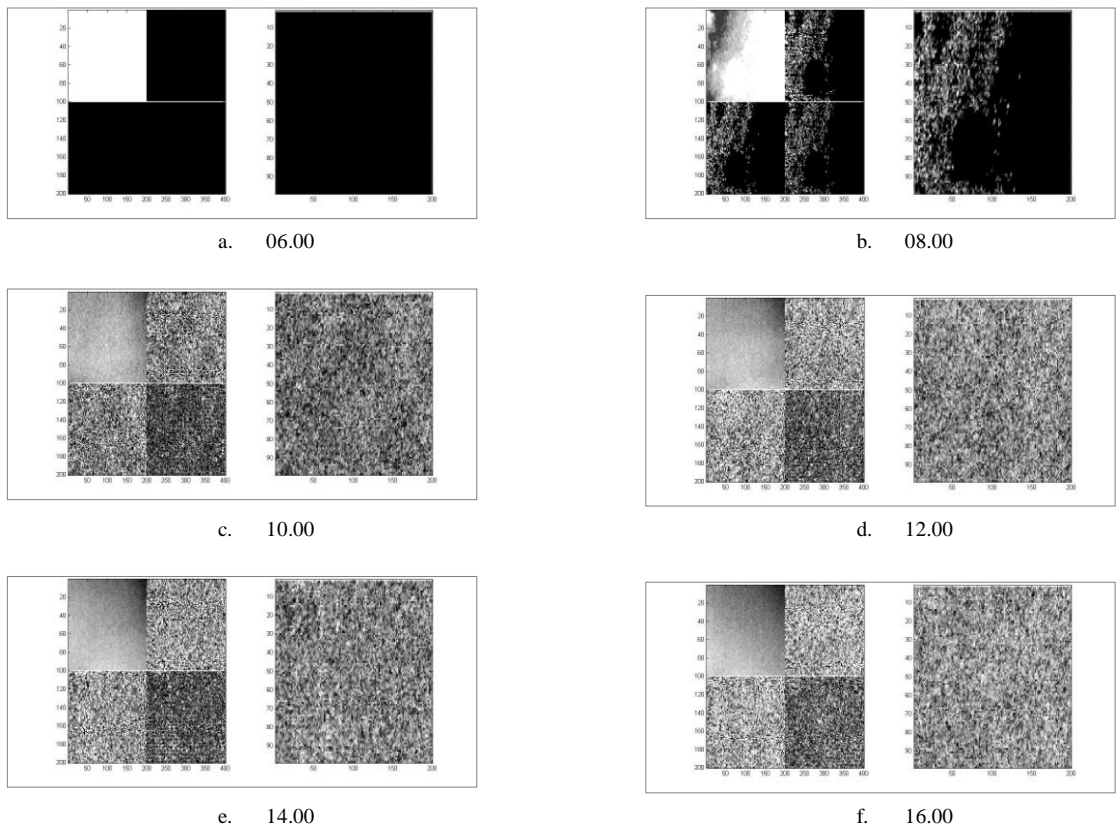

Fig. 5 Wavelet decomposition of infrared environmental condition images

V. CONCLUSIONS AND SUGGESTION

A. Conclusions

- The increasing air pollution characterized using wavelet decomposition by increasing index value from 0 (black)—3 (white) and amount of white spots about 60% (from 5% become 65%).
- Wavelet decomposition could be use to monitoring environmental condition, especially air pollution.

B. Suggestion

This research could be continuing with further research to get characteristic of air pollutant and monitoring air pollution.

ACKNOWLEDGMENT

Thanks to DP2M, Directorate of Higher Education, Ministry of Education and Culture, Republic Indonesia for profiding financial support through Competitive Grant (*Hibah Bersaing*), Contract Number 249/UN26/8/PL/2014, June 2, 2014.

References

- [1] Harmoko, A.S., Imawan, C., "A Distributed System for Air Quality Monitoring System," Proc. of 2005 National MIPA, FMIPA UI, 24 – 26 Nov. 2005
- [2] Jazi, E.S., Purwadi, E., "Remote Temperature Monitoring based on SMS," Proc. of 2005 National Seminar on Informatics, UAD, Yogyakarta, 2005
- [3] Marvin Ch.Wijaya & Agus Prijono, "Digital Image Processing using Matlab", Informatika, Jakarta, 2007.
- [4] S.R. Sulistiyanti., "Characteristic Filter Absorber Based on Influence Intensity Sun Variety", Proceeding Seminar Hasil Penelitian dan Pengabdian Masyarakat Universitas Lampung, 2007.
- [5] C. Fredembach, S. Süsstrunk, "Colouring the Near-infrared". In Proceedings of the IS&T/SID 16th Color Imaging Conference, pages 176-182. November 10-15. Portland, USA. 2008.
- [6] C. Fredembach, S. Süsstrunk. "Illuminant Estimation and Detection Using Near-infrared". In IS&T/SPIE Electronic Imaging, Digital Photography V, volume 7250, San Jose, USA, January 18-22, 2009.
- [7] S.R. Sulistiyanti, A. Susanto, FX. A. Setyawan, "Histogram Characterizations of Infrared Images Captured by a Modified Digital Camera", International Journal of Electronic Engineering Research (IJEER), Research India Publications (RIP), Vol. 1, No. 4, ISSN 0975 – 6450, pp. 329-336, 2009.
- [8] S.R. Sulistiyanti, A. Susanto, T.S. Widodo, G.B. Suparta, 2010, "Noise Filtering on Thermal Images Acquired by Modified Ordinary Digital Camera", Proceeding International Conference on Electronics and Information Technology (ICEIE), Kyoto, Japan, , 1-3 August 2010.
- [9] S.R. Sulistiyanti, A. Susanto, T. S. Widodo, G. B. Suparta, "Histogram Slicing to Better Reveal Special Thermal Objects", Proceeding Int. Conference on Signal and Image Processing (ICSIP), World Academy

of Science, Engineering, and Technology (WASET), 25-27 August, 2010, Singapore.

- [10] S.R. Sulistiyanti, A. Susanto, T.S. Widodo, G.B. Suparta, 2011, "Surface (2D) Fitting to Exhibit the Inaccessible Isotherms Contours of Thermograms Acquired by a Consumer Digital Camera", International Journal of Computer Science and Technology (IJCSST), Vol. 2 Issue 1, ISSN:0976-8491 (online), and ISSN: 2229-4333 (Print), 2011.
- [11] S.R. Sulistiyanti, Y. Burhanudin, S. Harun, "Characterization of Cutting Temperature and Ignition Phenomena of Magnesium Chip using Infrared Imaging", Advanced Materials Research, © (2012) Trans Tech Publications, Switzerland doi:10.4028/www.scientific.net/AMR. Vols. 588-589, pp. 1744, 2012.
- [12] Gonzalez, R.C., Richard E. Woods, "Digital Image Processing", Prentice-Hall, Inc., Upper Saddle River, New Jersey, 2008.
- [13] A. Pizurica, W. Philips, I. Lemahieu and M. Acheroy, "Image denoising using a multiscale nonlinear filtering technique," in *Proc. Internat. Symp. on Intelligent Vision Systems ACIVS*, pp. 9–13, Baden-Baden, Germany, 5-6 Aug 1999.

AUTHOR INDEX

Abadi, Imam	370	Galih, Savitri	455
Abdillah F. I.	238	Gani, Prati Hutari	122
Abdualgader, Dreis	398	Gautama, Gian	232
Abdurohman, Maman	122	Gemini, Vipin	81
Abraha, Kamsul	77	Hafizh, Idham	19
Abuelenin, Sherif M.	61	Haikal, Muhammad Agil	392
Achmad, Muhamad Iradat	158	Hakim, L.	170
Adi, Wisnu Kuntjoro	417	Hantono, Bimo Sunafri	244
Adiatmoko, M.F.	142	Hasibuan, Zainal A.	254
Adiono, Trio	19	Hatta, Heliza Rahmania	127
Adji, Teguh Bharata	165,290	Hendarto, Hugo Adeodatus	33, 39
Afif, Ruchaemi	259	Hermawan	407, 411
Agus, Fahrul	127	Hernanda, IGN Satriyadi	238, 365
Akil, Yusri Syam	381	Hery P, Mauridhi	417
Akrom, Afdhal	103	Hidayat, S.S.	28
Alotaibi, Mohammed	207	Hidayat, Sidiq Syamsul	24
Altwaijry, Hesham A.	302	Hidayatno, Achmad	314
Alwakeel, Sami S.	302	Hoffmann, Marc	455
Anggara, Jovan	232	Hugeng	232
Anggraini, Ratih Nur Esti	271	Hutoro, Koko	142
Anif, M.	28	Ilham, Julian	44
Anif, Muhammad	24	Isnanto, R. Rizal	181
Ardelina, Nancy	445	Istiadi	265, 285
Ardyanto, Aditya Ferry	19	Iswanto	87
Arifin, Zainal	296	Iwamoto, Kazuyo	131
Asfani, Dimas Anton	238, 365	Kaiser, Thomas	455
Ashari, Mochamad	375,386,402	Karnoto	407
Aslam, M. Usman	333	Kartinisari, Evril N.	365
Ayuningtias, Defrin Karisia	308	Khairina, Dyna Marisa	296
Budi, Indra	254	Koesuma, Sorja	28
Buntat, Zolkafle	407	Komarudin, M.	170
Cahyadi, Adha Imam	66, 87	Krismawardana, Yoga	449
Cheema, Muhammad Bilal	333,338	Kurnianingsih	24, 97
Cheema, Muhammad Usman	333	Kurosaki, Masayuki	175
Christyono, Yuli	449	Lambang, Subagyo	259
Chung, Wan-Young	44	Lestari, Andrian Andaya	459
Dalmi, Kessya Din	271	Macrina, Ajub Ajulian Zahra	314
Daoud, Ahmad A.	61	Mardiana, Siti	225
Darwis, Rizadi Sasmita	436	Mukti, Prasetyono Hari	436,445
Djaelani, Elan	50	Munadi	33,39
Djunaidy, Arif	280	Munandar, Devi	72
El-Rabaie, El-Sayed M.	14	Murthy, Pessapaty S.R Chandra	327
Elgreatly, Ahmed Lutfi	14	Murtianta, Budihardja	427
Endroyono	436	Musa, Ahmad	323
Eridani, Dania	187	Musyafa', Ali	370
Facta, Mochammad	398, 407	Nan Cenka, B. A.	318
Fahmi, Daniar	238, 365	Nugroho, F.X. Satriyo D.	290
Fahrul, Agus	259	Nugroho, Hanung Adi	66, 137, 158, 165
Falahah	308	Nugroho, Lukito Edi	97,285
Fanani, Nurul Zainal	216	Nurhayati, Oky Dwi	202
Faris, Muhammad	66,87	Nurrahmi, Siti	77
Fauziati, Silmi	290	Ochi, Hiroshi	175
Firdaus, Aji Akbar	345	Okane, Toshimitsu	131

Pandini, Meta Lara	296	Soesanti, Indah	249
Paramartha A.A.G. Y.	318	Studiawan, Hudan	211
Paramartha, A.A.G. Yudhi	254	Subiyanto, L.	142
Penangsang, Ontoseno	142	Sugiarto, Bambang	50
Pradhana, Harindra Wisnu	117	Suharjono, A.	28
Prakoso, Bagas Sakamulia	153	Suharjono, Amin	24
Pramudita, Kevin Eka	56	Suharjono, Lateko	381
Prasetijo, Agung B.	302	Suhartomo, Antonius	422
Prasetyo, Hermawan	275	Sulistiarini, Emma Budi	265
Prasetyo, Totok	24	Sulistiyanti, S. R.	170
Pratomo, Leonardus H.	323	Sumaryono	259
Priananda, Ciptian Wieried	392	Supriyo, B.	28
Priyadi, Ardyono	417	Suryanegara, Muhammad	432
Priyogi B.	318	Suryani, Titiek	436
Pujiantara, Margo	417	Susanto, Adhi	113, 158
Purwarianti, Ayu	275	Susilo, Deddy	427
Putra, Alexander W Setiawan	422	Sutiono, Michael Aditya	232
Putra, Guntur Dharma	265	Suwadi	436
Putra, Septian Gilang Permana	19	Suyanto	345
Rachman, Isa	142	Syafaruddin	381
Raharja , Nia Maharani	87	Syafei, Wahyul Amien	175
Raharya, Naufan	432	Syafraditya, Tierta	109
Rahmawati, Yani	192,198	Syahputra, Ramadoni	386,402
Rajagukguk, Antonius	375	Syai'in, Mat	142
Rakhman, Arkham Zahri	97	Syakur, Abdul	411
Ratri, Ignatia Dhian Estu Karisma	165	Syamsi, Djohar	72
Riawan, Dedet Candra	375	Teguh M, Kurniawan	202
Riyadi, Munawar A.	449	Timotius, Ivanna K.	153, 221
Riyadi, Slamet	350	Tjokronagoro, Maesadjie	113
Robandi, Imam	386	Tokunaga, Hitoshi	131
Rochimah, Siti	271	Triandini, Evi	280
Royce, Eduard	221	Triyana, Kuwat	77
Rubhasy A.	318	Tumbelaka, Hanny H.	360
Rubhasy, Albaar	254	Ubaya, Huda	103
Sakti, Indra	91	Umiati, Ngurah Ayu Ketut	77
Salam, Zainal	407	Utami, Eva Yovita Dwi	427
Samran	338	Utomo, Christiono	192, 198
Samran, Muhammad	333	Vani, Alamuru	327
Santosa, Paulus Insap	187,285	Wahyudi F., Imam	417
Santoso, Imam	113	Wanda, Putra	244
Saputra, Laurentius Kuncoro Probo	137	Waris, Tajuddin	381
Selo	244	Wibisono, Gunawan	109
Serliningtyas, Herlinda	459	Wibisono, Stanley Suryono	148
Setiawan, F. Budi	56	Widiastuti, Ika	216
Setiawan, Florentinus Budi	148, 441	Widjaja, Imanuel	232
Setiawan, Joga Dharma	33, 39	Widodo, Thomas Sri	113
Setijadi, Eko	445	Widyawan	97
Setiono, Felix Y.	323, 355	Winarko, Oktanto Dedi	459
Setyawan, Iwan	153, 221	Wirawan	436
Shaaban, Ahmed A.	14, 61	Wulandari, Meirista	137
Shiddiqi, Ary Mazharuddin	211	Yohana, Eflita	398
Sholeh, Rahmat	127	Yudamson, A.	170
Siahaan, Daniel	280	Yulian, Deni	459
Siswanto	56		
Soedibyoy	345,392,402		
Soeprijanto, Adi	142, 370		



2014

The 1st International Conference
on Information Technology,
Computer, and Electrical Engineering

ICITACEE



**DEPARTMENT OF ELECTRICAL ENGINEERING
DIPONEGORO UNIVERSITY**
Jalan Prof. Sudarto, SH, Tembalang
Semarang, 50275, Indonesia

