

Development of a Model of Hydro Electric Power Generation Suitable for Low Head

Jorfri Boike Sinaga, Novri Tanti, Ahmad Suudi, M. Dyan Susila

Mechanical Engineering Department, Faculty of Engineering, University of Lampung
jorfri6@yahoo.com
rianti_dc@yahoo.com
ahmad.suudi@eng.unila.ac.id,
dyansusila@gmail.com

Abstract. Rural Electrification Program is a policy of Indonesian government on the electricity sector for the expansion of electricity access in rural areas. Least resources is one of the major causes which has left many villages in Indonesia without electricity. One solution to these problems is renewable energy resources, and use of these energy resources offer tremendous opportunity to electrify rural areas, including hydro-power. This article describes the equipment and operating principle of a model of hydro electric power generation developed in laboratory of fluid mechanics at the Mechanical Engineering Department, University of Lampung, and also presents the testing results obtained in small irrigation canal of Way Tebu in Desa Banjar Agung Udik, Kecamatan Pugung, Kabupaten Tanggamus, Provinsi Lampung.

Key words: low head, stream flows energy, helical turbine, hydro power

1. Introduction

Lampung Province with an area of 3,528,835 ha has considerable renewable energy resources potential as a substitution for fossil energy. One of the renewable energy is environmentally friendly is hydro power and its potential in Lampung Province is estimated to reach 2,697.4 MW [1]. Currently, these potentials are mostly used as large scale hydro power plants. Alternative utilization of hydro power that has been popular in Indonesia and has the potential to be developed in this area is a small-scale hydro power plant or better known as Micro hydro Power Plant (MHPP). Utilization of the potential of water energy is deemed very necessary to supply of high demand of electricity, where currently there is a deficit of electrical energy. This deficit has occurred because of a relatively high rate of electricity demand growth in Lampung Province of 15% per year compared to the government's ability to provide electricity supply [2].

Hydraulic turbines commonly used in hydro electric power generation systems utilize energy of hydro power with high flow head. While many the potential of hydro power only have ultra low head or free flow energy (hydrokinetic energy) and not yet use for the hydro electric power generation.

In this paper, design, develop and testing results of ultra low head hydraulic turbine used in model of hydro electric power generation system are presented. This study is application of research that has been done by Sinaga et al.,[3]. The purpose of this research is: to determine the parameters of ultra low head hydraulic turbine used in model of hydro electric power generation system to utilize the potential of stream flow energy in irrigation canal of Way Tebu in Desa Banjar Agung Udik, Kecamatan Pugung, Kabupaten Tanggamus, Provinsi Lampung

1.1. Water Turbine for Very Low Flow Head

For decades scientists have tried to use conventional turbines for low flow heads. Highly efficient water turbines for high flow heads are very expensive when applied to hydro power stations with low or very low heads. The main types of water turbines currently used to harness hydro power are:

Kaplan, Francis, Pelton, and cross flow turbines. The Kaplan turbine is one of the water turbines which technically can be used for a two meter head height or a lower water head but the turbine operating unit cost increases up to about four times when the water heads fall from 5 to 2 meters.

In 1931 Darrieus patented reaction turbine to use low or very low head flow energy (free flow). This turbine has a drum-like shape with a number of straight or curved blades of airfoil and a shaft that is perpendicular to the fluid flow. This turbine allows high torque for slow current flow, and provides a large fluid flow through the turbine without enlarging the diameter. However, the Darrieus turbine has not been acceptable for large applications, mainly due to fluctuations during rotation and relatively low efficiency. Fatigue failure of the blade generally occurs in this turbine due to the nature of the vibration that occurs. This turbine also has an initial operating problem at low rotational speed due to a straight blade that changes the angle of attack.

Gorlov [4] explained the helical turbine has the same advantages as the Darrieus turbine, for example: able to pass a large mass of water for slow flow, kinetic energy capturing, and the low cost turbine for using a very simple rotor blade. The helical arrangement of the rotor blades also makes the performance of the helical turbine better as compare with the Darrieus turbine. It results the characteristics: uniform turbine rotation at high speed in relatively slow fluid flow, unidirectional rotation in reversible fluid currents, high efficiency, no fluctuating torque, no cavitation in water for high rotating speed, self-starting better in slow flow of waters.

An approximation of the vertical axis turbine is used to calculate the power was generated by this helical turbine blade, as can be seen in Figure 1. The resultant velocity vector (\vec{W}) is the sum of the velocity vector of fluid (\vec{V}) and the velocity vector of the advancing blade (\vec{U}).

$$\vec{W} = \vec{V} + (-\vec{\omega} \times \vec{R}) \quad (1)$$

Where R is the radius of the turbine (m), and ω is the angular velocity of turbine (rad/ s).

From the Figure 1, the resulting of fluid velocity varies, the maximum is found for $\theta = 0^\circ$ and the minimum is found for $\theta = 180^\circ$, where θ is the azimuthal or orbital blade position. The angle of attack α is the angle between the resultant vector velocity (\vec{W}), and blade's chord. From geometrical considerations, the resultant of flow velocity and the angle of attack are calculated as follows:

$$W = V \sqrt{1 + 2 \cos \theta + \omega^2 R^2} \quad (2)$$

$$\alpha = \tan^{-1} \left(\frac{\sin \theta}{\cos \theta + \omega R} \right) \quad (3)$$

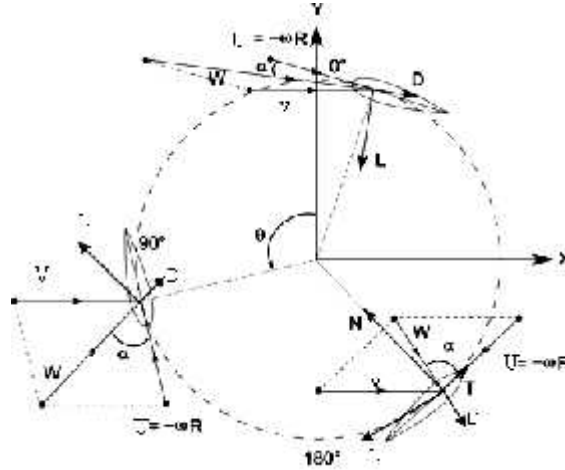

Figure 1. Forces and velocities acting in a vertical axis wind turbine for various azimuthal positions.

Where λ is tip speed ratio, and can be calculated by using the following equation

$$\lambda = \frac{\omega R}{U} \quad (4)$$

The resultant aerodynamic force is composed in the lift force (F_L) and drag force (F_d) which these forces can be calculated using the following equation:

$$F_d = \frac{1}{2} C_d \rho V^2 A \quad (5)$$

$$F_l = \frac{1}{2} C_l \rho V^2 A \quad (6)$$

Where C_d is the coefficient of drag, C_l is the lift coefficient, ρ is fluid density (kg / m^3), V is fluid velocity (m/s), and A is cross-sectional area of the hydro foil blade (m^2).

The force perpendicular to the arm (radius) of turbine, the torque by projecting lift and drag forces can be calculated using the following equation:

$$T = (F_l \cdot \sin r - F_d \cdot \cos r) \times R \quad (7)$$

Where T is the torque (N.m), F is the force perpendicular to the arm (N), and R is the radius (m)

From Equation 7, the shaft power P_b (W) can be calculated using the equation:

$$P_b = T \omega \quad (8)$$

1.2. Mathematical Model for Design of Helical Turbine

In Figure 2 [4], It can be seen helical blades formed AME lines on the surface of a cylinder having height L and radius R . The helical blade equation is defined by:

$$X = R \cos \{ \quad Y = R \sin \{ \quad Z = R \{ \cos u \quad (9)$$

Where x , y and z are the coordinates of the point M of the helix, and u is the angle of inclination of the blade to the XOY plane.

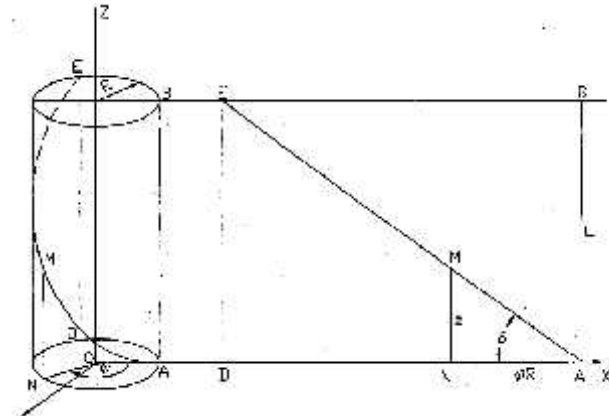

Figure 2. Projection of the blade line on vertical plane.

As an approximation that the cross section of the blade has the shape of an infinitely thin rectangle with its length equal to the chord c of the blade's airfoil. This does not change the proportion between lifts and drags after resolution of the reaction force F which can be calculated as:

$$F = k_0 A V^2 \quad (10)$$

Where: k_0 is a constant, ρ is water density, A is projection of the frontal area of the blade on the plane perpendicular to the water flow, and V is velocity of water.

The total starting torque developed by the turbine blades in the water flow can be expressed by the equation

$$T = k_2 \frac{\sqrt{1+q^2}}{2} \sin^2 \left(\frac{L}{Rq} \right) \quad (11)$$

Where $k_2 = \frac{1}{2} k_1 R$, $k_1 = k_0 b V^2 R$, $q = \tan u = \frac{L}{Rq}$, and l is the length of the blade.

In dimensionless can be written

$$T_1 = \frac{T(q)}{k_2} = \frac{\sqrt{1+q^2}}{2} \sin^2 \left(\frac{L}{Rq} \right) \quad (12)$$

Figure 3 [3] shows the torque T , as a function of angle of blade inclination and the ratio of the turbine height to its radius L/R .

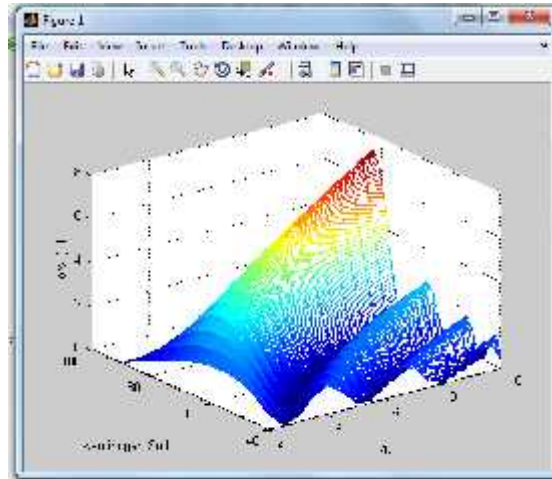

Figure 3. The torque relation T_1 as a function of angle of blade inclination and the ratio of the turbine height to its radius L/R .

2. Research methods.

2.1 Determining the Potential of Hydro Power

Surveyed must be done to Way Tebu irrigation location in Desa Banjar Agung Udik, to obtain data of velocity of flow and cross section area of irrigation canal. These data were used to determine the potential of hydro power in Way Tebu irrigation canal.



Figure 4. Irrigation canal of Way Tebu.

2.2 Determining the Turbine Parameters

The turbine to be designed for use in the model of hydro electric power generation is shown in Figure 5. The parameters of turbine to be determined: height of turbine L , diameter of turbine D , shape of blade, number of blades n , and angle of blade inclination .



Figure 5. Model of helical turbine.

2.3. Construction of Model of Hydro Electric Power Generation

Scheme of model of hydro electric power generation can be seen in Figure 6. The main components of the model are helical turbine, belt pulleys of power transmission, and generator. This device transforms kinetic energy, derived from river currents or flow of low head, to turn a turbine, which in turn turns a generator that produces electricity.

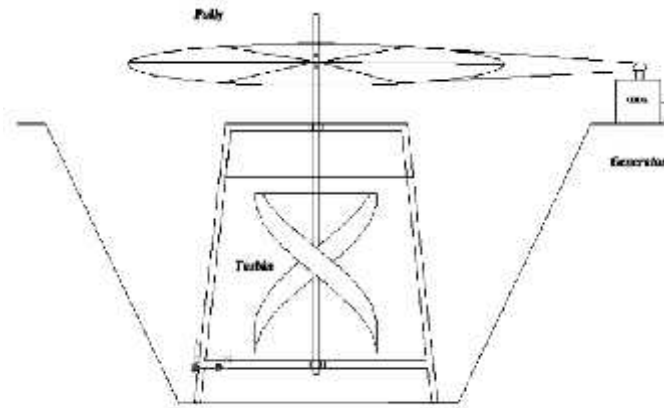

Figure 6. Model of hydro electric power generation

The efficiency η_{sys} of model of hydro electric power generation system can be calculated using the equation:

$$\eta_{sys} = \frac{P_{el}}{0,5 \cdot \rho \cdot A_t \cdot V^3} \quad (13)$$

where P_{el} is electrical power generated (W), ρ is water density (kg/m^3), V is velocity of water flow (m/s), and A_t is cross sectional area of helical turbine (m^2).

3. Results And Discussion

3.1. Potential of Hydro Power of Way Tebu

After survey was done to Way Tebu irrigation canal, the data of velocity of flow and cross-sectional area of the canal was obtained. The velocity of flow in canal was measured by propeller flow meter and obtained velocity of flow of 0,8 m/s. The cross-sectional area of canal is $4,982 \text{ m}^2$, as shown in Figure 7.

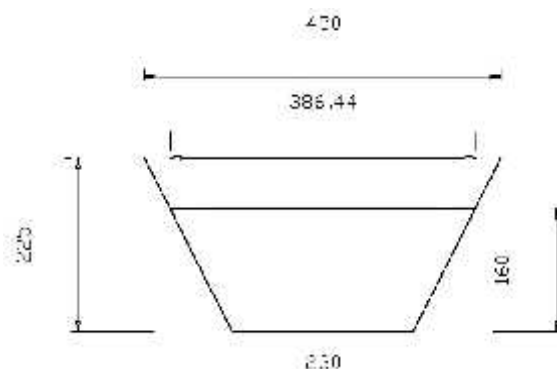

Figure 7. Cross sectional area of of irrigation canal of Way Tebu.

Potential of hydraulic energy in the Way Tebu irrigation canal can be calculated by:

$$P_w = \frac{1}{2} \rho A V^3$$

$$= 1275 W$$

where P_w is hydraulic energy of irrigation canal (W), ρ is water density (kg/m^3), A is the cross sectional area of canal (m^2), and V is velocity of flow (m/s).

3.2. Turbine Design

Generally helical turbine uses blade's airfoil, due to its high efficiency and produces a large pressure difference between two sides of blade to rotate with a considerable force moment in which the force moment is generated by lift and drag force. The lift and drag forces that occur in the airfoil sections are influenced by the shape of blade and the angle of attack. The symmetry of NACA 0020, NACA 0025 and NACA 0030 airfoils was used for the turbine blade.

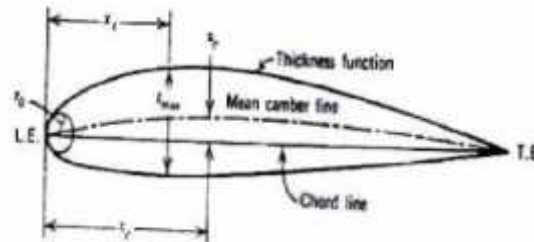

Figure 8. NACA airfoil.

According to the conditions of irrigation canal of Way Tebu, as shown in Figure 4, helical turbine to be used has 2 m in diameter and 1 m in height. Using equation (12), for the ratio of height to radius of turbine L/R of 2,4, it was obtained the angle of blade inclination of 62° as shown in Figure 9

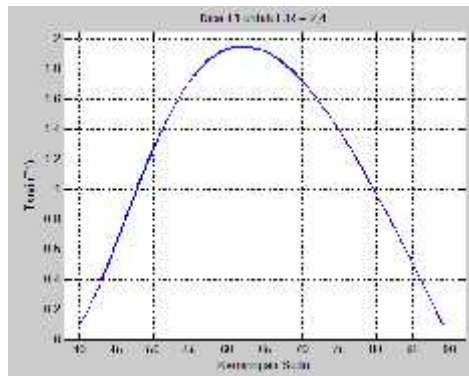

Figure 9. Torque T as a function of angle of blade inclination for $L/R=2,4$

The performance of helical turbine operation is also influenced by relative solidity. It can be calculated using the equation [5]:

$$\dagger = \frac{S}{2LR} \quad (14)$$

Where \dagger is parameter of relative solidity, S is solidity of the helical turbine, L is height of the turbine, and R is radius of the turbine. Solidity of the helical turbine can be calculated using the equation:

$$S = \frac{2nLR}{f} \left(d + \sum_{k=1}^n \sin\left(\frac{fk}{n} - d\right) - \sin\frac{fk}{n} \right) \quad (15)$$

Where n is the number of blades, and d is half of the blade's chord in radians with respect to the axis of rotation.

Figure 10 [6] is shown the effect of tip speed ratio to coefficient of performance C_p (efficiency) for each relative solidity of hydrokinetic turbine (HKT) Darrieus with straight blade.

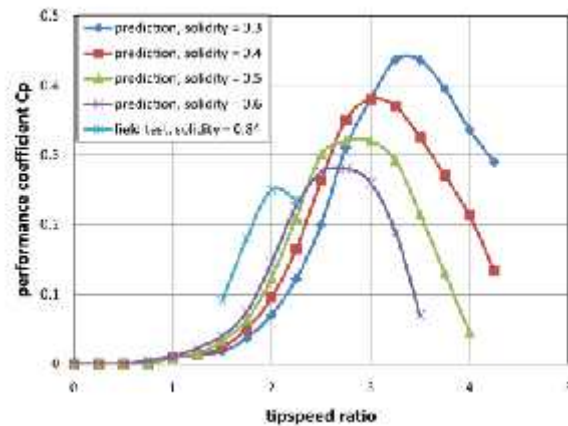

Figure 10. Predicted and measured performance of Darrieus HKTs of varying solidity.

The tip speed ratio of turbine operation was determined $\lambda = 3$ [5], this is to prevent cavitation during turbine operation. From Figure 10, for tip speed ratio $\lambda = 3$, it was obtained the relative solidity 0.4. Based on previous study [7], operating the helical turbine with 3 blades was given the maximum efficiency. Using Equation 13 and 14, it was found the length of chord's blade of 25 cm.

3.3. Testing of Model

The helical turbine and the model of hydro electric power generation system tested on the irrigation canal of Way Tebu is shown in Figure 11, and 12. Rotation of the turbine and the generator were measured by tachometer and the electrical power generated by generator was measured by Ammeter and Voltmeter. To increase the performance of helical turbine, the study on effect of the flywheel weight on performance of the helical turbine also conducted. The flywheel is a rotating mass, and is used as a machine of power store. Power is stored in the flywheel in form of the kinetic energy

$$T = \frac{1}{2} I \omega^2 \quad (24)$$

Where, I is moment of inertia of the flywheel against its rotational axis, and ω is the angular velocity. As the energy increases and the spin also increases, and power is stored in the flywheel. At a time when the engine or system is less of power then flywheel will provide power. The flywheel used in this test consists of 6 disc shaped plates with diameter of 50 cm, and weight each disc was 5 kg.



Figure 11. Helical turbine used in model.



Figure 12. Model of the hydro electric power generation system.

3.4. Results and Discussion

Figure 13, 14 and 15 are given the testing results of effect of the blade shape on performance of the model of hydro electric power generation system. From the test results in Figure 13, where testing using the blade shape of NACA 0030 gives an efficiency of 33.78%, better as compare with the blade shape of NACA 0025, and NACA 0020. This is due to the operation of turbines using the blade shape of NACA 0030 produced greater lift forces compared with the blade of NACA 0025, and NACA 0020. And operation of this helical turbine was at the tip speed ratio of 1.65.

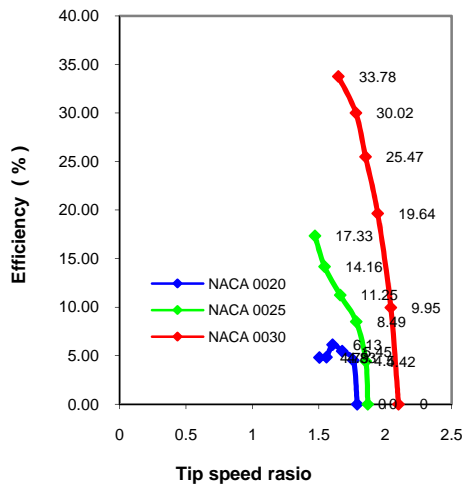

Figure 13. Curve of efficiency versus tip speed ratio turbine for various shape of turbine blades

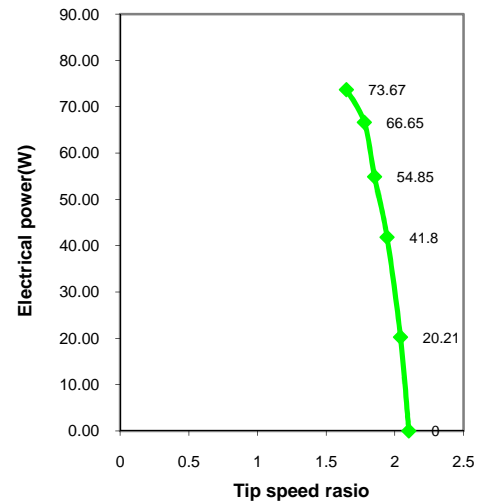

Figure 15. Curve of electrical power versus tip speed ratio turbine for using blades of NACA 0030.

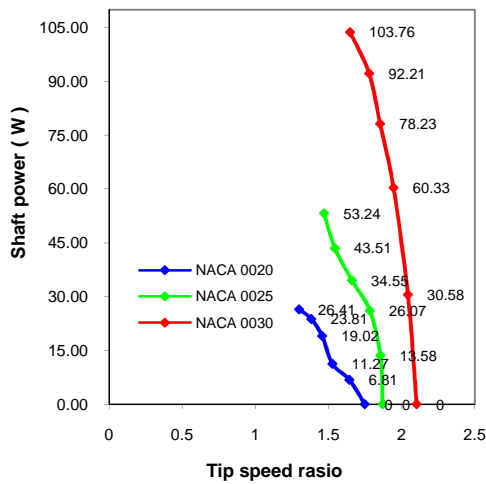

Figure 14. Curve of shaft power versus tip speed ratio turbine for various shape of turbine blades.

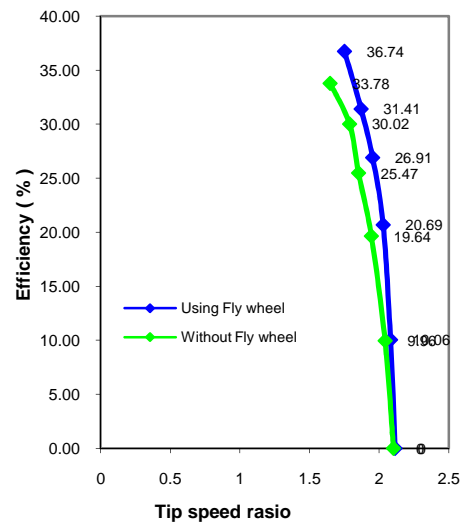

Figure 16. Curve of Efficiency versus tip speed ratio of turbine using *fly wheel* of 15 kg.

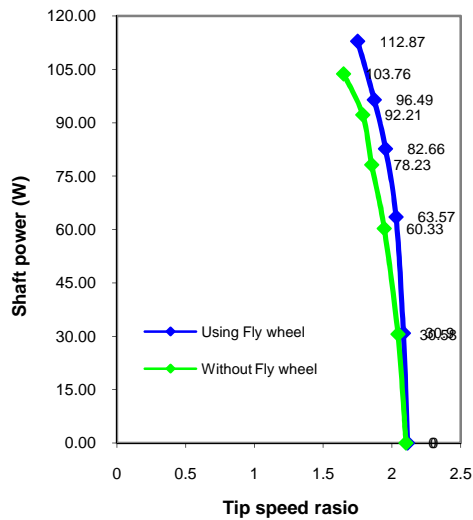

Figure 17. Curve of shaft power versus tip speed ratio of turbine using *fly wheel* of 15 kg

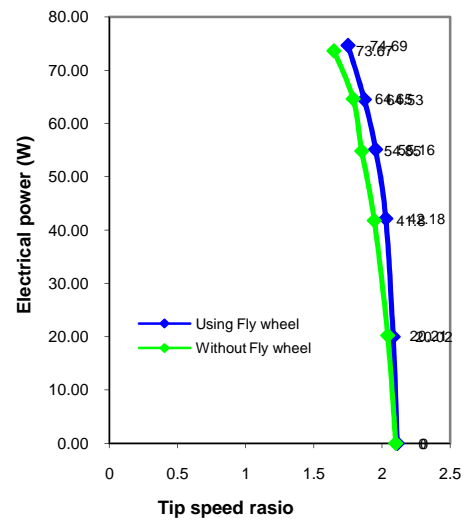

Figure 18. Curve of electrical power versus tip speed ratio of turbine using *fly wheel* of 15 kg.

Testing results of the model of hydro electric power generation system using flywheel is shown in Figure 16 to 18. It shows an increase in the shaft power and the efficiency of turbine operation. The turbine operation used the flywheel weight of 5 kg generating maximum power of 112,87 W and the efficiency become 36.74% at tip speed ratio of 1,75. It shows the addition of loading by using the flywheel increases the moment of inertia produced which for moment of inertia itself is affected by weight of the flywheel. And when the turbine receives the load from the generator then the flywheel will provide its energy.

With using this turbine in the hydro electric power generation system the potential of low velocity of stream flow energy can be used to generate the electrical energy for the communities living in remote area. The result of electrical energy that can be generated by using helical turbine in the model of hydro electric power generation system is about 36,74% of source of the stream flows energy, and to meet the amount of electricity demand this turbine can be installed in series or parallel.

4. Conclusions

Based on the results that have been obtained and described above earlier, it can be taken some conclusions:

1. In this research is given helical turbine design method for model of hydro electric power generation system to use the stream flow energy which has very low head or only kinetic energy such as the stream flow energy in Way Tebu canal irrigation with flow velocity of 0.8 m /s.
2. The test results show the maximum of turbine efficiency of 33.78% when using blade's airfoil of NACA 0030, better as compare with the blade's shape of NACA 0025, and NACA 0020.
3. Improvement of the turbine performance can be conducted by using flywheel, and testing result using weight of flywheel of 15 kg and diameter of 50 cm increase shaft power and efficiency of turbine to 112,87 W and 36,74% respectively.
4. Using this turbine in the hydro electric power generation system the potential of low velocity of stream flow energy can be used to generate the electrical power for the communities living in remote area.

References

- [1] Fikri, M. A. 2008 Alternatif Energi Terbarukan dan Konversi Energi. PLN Lampung Available: www.plnlampung.co.id/warta_PLN.htm. Accessed on March 18, 2010.
- [2] Sampurna, H. 2014). Pertumbuhan Permintaan Listrik di Lampung Cukup Tinggi. Available: <http://www.saibumi.com/artikel-2423-pertumbuhan-permintaan-listrik-di-lampung-ukup-tinggi.html#ixzz4xZCP9k00>. Accessed on August 22, 2017.
- [3] Sinaga, J. B., N. Tanti, dan M. Badarruddin. 2012. Rancang Bangun Turbin Air *Ultra Low Head* untuk Sistem Pembangkit Listrik Tenaga Mikro Hidro (PLTMH) Guna Mendukung Program Desa Mandiri Energi di Provinsi Lampung. Report of Penelitian Strategis Nasional.
- [4] Gorlov, A. 2008. Development of The Helical Reaction Turbine. Final Technical Report (DE-GO1-96EE 15669).
- [5] Gorlov, A. 2010. Helical Turbine and Fish Safety Available: www.mainetidalpower.com/files/gorlovrevised.pdf. Accessed on April 22, 2011.
- [6] Kirke, B. K. 2011. Tests on ducted and bare helical and straight blade Darrieus hydrokinetic turbines *Renewable Energy*. No. 36 : 3013-3022.
- [7] Supramanto, D. 2016. Kajian Eksperimental Pengaruh Jumlah Sudu terhadap Unjuk Kerja Turbin Helik untuk Sistem Pembangkit Listrik Tenaga Mikro Hidro (PLTMH). Report of Under Graduate Project, Mechanical Engineering, University of Lampung.