

# ABSORPTION OF CO<sub>2</sub> FROM MODIFIED FLUE GASES OF POWER GENERATION TARAHAH CHEMICALLY USING NaOH AND Na<sub>2</sub>CO<sub>3</sub> AND BIOLOGICALLY USING MICROALGAE

Elida Purba\*), Dewi Agustina, Finka Putri Pertama, and Fita Senja.

The Department of Chemical Engineering, Fakultas Teknik, Universitas Lampung, Lampung, Indonesia

## *Abstract*

This research is carried out on the absorption of CO<sub>2</sub> from the modified flue gases of power generation Tarahan using NaOH (sodium hydroxide) and Na<sub>2</sub>CO<sub>3</sub> (sodium carbonate). The operation was conducted in a packed column absorber and then the output gases from the packed column was fed into photo-bioreactor for biological absorption. In the photo-bioreactor, two species of microalgae, *N. occulata* and *T. chuii*, were cultivated to both absorb CO<sub>2</sub> gas and to produce biomass for algal oil. The aim of this research is, first, to determine the effect of absorbent flow rate on the reduction of CO<sub>2</sub> and on the decrease of output gas temperature, second, to determine the characteristics of methyl ester obtained from biological absorption process. Flow rates of the absorbent were varied as 1, 2, and 3 l/min. The concentrations of NaOH and Na<sub>2</sub>CO<sub>3</sub> were 1 M at a constant gas flow rate of 6 l/min. The output concentrations of CO<sub>2</sub> from the absorber was analyzed using Gas Chromatography 2014-AT SHIMADZU Corp 08128. The results show that both of the absorbents give different trends. The absorption using NaOH can be concluded that the higher the flow rate the higher the absorption rate. The highest flow rate gives maximum absorption of 100%. On the other hand, absorption with Na<sub>2</sub>CO<sub>3</sub> gives the opposite trend where the higher the flow rates the lower the absorption rate. The highest absorption using Na<sub>2</sub>CO<sub>3</sub> is obtained with the lowest flow rate, 1 l/min, that is 45,5%. As the effect of flow rate on output gas temperature, the temperature decreases with increasing flow rates for both absorbents. The output gas temperatures for NaOH and Na<sub>2</sub>CO<sub>3</sub> are consecutively 35 °C and 31 °C with inlet gas temperature of 50°C. Absorption of CO<sub>2</sub> biologically gives a reduction of CO<sub>2</sub> up to 60% from the input gas concentration. Algal oil is extracted with mixed hexane and chloroform to obtain algal oil. Extracted oil was transesterified to methyl ester using sodium hydroxide as a catalyst. The results of in-situ transesterification method cannot be identified. Both of microalgae give maximum yield at 2% catalyst concentration. *Nannochloropsis occulata* gives the highest yield that is 88.5%. The highest content of methyl ester from *Nannochloropsis occulata* is undecanoic acid methyl ester by 55.42% and the result from *Tetraselmis chuii* is palmitic acid methyl ester by 81.58%.

*Keywords: CO<sub>2</sub>, chemical absorption, biological absorption, microalgae*

## 1. INTRODUCTION

Pollution has caused a lot of damage to the environment. One of waste that can be a threat to the environment is CO<sub>2</sub>, which is increasingly increasing and can degrade air quality. Most of the CO<sub>2</sub> that is released into the environment is a result of human activities, for example on steam power generation Tarahan in South Lampung. The amount per hour is not massive but, the buildup can occur if CO<sub>2</sub> is continuously released without further treatment.

Action can be taken by absorption of CO<sub>2</sub> chemically and biologically. The biological absorption is carried out by using microalgae, where CO<sub>2</sub> will be absorbed by microalgae in the photosynthesis process. Besides reducing CO<sub>2</sub>, this process can produce biodiesel using algal oil from microalgae. Microalgae have the lipid content of more than 30% and productivity of microalgae 200 times more than other vegetable sources, so it can be used as an alternative source of biodiesel (Christi, 2007). On the other hand, the chemical absorption is applied using absorbents where absorbents are contacted with CO<sub>2</sub> in the absorber.

Research on CO<sub>2</sub> absorption has been published in literature. Previous study by Hasnan et al. (2012), show that the initial absorption decreased at a flow rate of 0.2 l / min to 0.4 l / min, and then absorption increased at a flow rate of 0.4 l / min to 0, 6 l / min. The initial condition was due to unsteady process. He found that the greater the flow rate of fluid the lower the  $k_{GA}$  due to the unsteadiness of flow. When the flow rates is steady then the value of  $k_{GA}$  is greater. The  $k_{LA}$  decrease with increasing the flow rate but then it is increase with higher flow rates. Cundari et al. (2014) obtained an optimum concentration in the CO<sub>2</sub> reduction process that is 25% by weight of Na<sub>2</sub>CO<sub>3</sub>. The effect of the addition of boric acid (H<sub>3</sub>BO<sub>3</sub>) to the solution in has been determined where the best boric acid concentration was at 3% by weight with the CO<sub>2</sub> gas absorption of 67.81%. However it increased the absorption rate up to 2.4 times.

Theoretically, chemical gas absorption is a process of mass transfer between two phases, gas and liquid, in which mass transfer occur when there is a driving force from one phase to another. The force of motion is a collision between molecules during mixing of fluid due flow rate velocity or forced mixing. Therefore, the greater the collision between molecules, the higher the absorption rate (Aditya et al., 2012). The operating temperature affects the size of an absorber in the absorption operation. High temperatures affect the absorption capacity where the temperature enhances the reaction mechanism in the absorber (Ndiritū et al., 2011).

Many research has been done by utilizing microalgae as a CO<sub>2</sub> absorbent with different types of microalgae. The commercial production of biodiesel derived from microalgae is still in the research and development stage, mainly due to the current prohibitive high costs associated with the biomass production and fuel conversion process. The schemes of research and development are optimizing parameters of operation such as the reaction time, the ratio of alcohol and microalgae lipid, catalyst concentration, and reaction temperature. In conventional trans-esterification, the extraction of lipid from microalgae was carried out by percolation using mixture of polar and non-polar solvents, such as methanol and chloroform. The oil was then trans-esterified into methyl ester in batch. Many research have been carried out to determine the best operating condition for the extraction of microalgal oil.

However, this method takes a long time and therefore it requires high cost. Therefore, the more attractive alternative is being developed, namely the in-situ method or trans-esterification of biodiesel without the extraction step. In this research, the experiment was carried out not only about the ability of alkaline solutions and microalga in reducing CO<sub>2</sub>, but also the potential of microalgae species in producing algal oil.

Previously, the studies were carried out separately either chemically or biologically. In this study, the absorption is carried out both chemically and biologically. The flow rates of the absorbent were 1, 2, dan 3 l /min. This is higher than the flow rate used by Hasnan et al. (2012). This is because the height of absorber in this study is larger than that applied by Hasnan. Similarly, as explained by Purba, et al. (2006 & 2010) high absorber and flow rates have an effect on overall mass displacement.

## **2. RESEARCH METHODS**

### ***2.1 Chemical Absorption***

#### *A. Materials*

The main equipment is packed column made from acrylic with a diameter of 7.5 cm and height of 127 cm). The packed column was filled with packing (based aluminum pipe mixture with a diameter of 8 mm, length of 2 cm and height of stuffing packingon columns 70 cm). Supporting equipment are a heater, air pump, gas flowmeter, liquid flowmeter, thermometer, and gas chromatography for analysis.

The absorbent was 1 M NaOH and Na<sub>2</sub>CO<sub>3</sub>. They were made from 40 grams of NaOH crystal dissolved in 10 liters of water and 1.06 kg of Na<sub>2</sub>CO<sub>3</sub> dissolved in 10 liters of water. Na<sub>2</sub>CO<sub>3</sub> was mixed with the H<sub>3</sub>BO<sub>3</sub> as a catalyst of 3% weight. The CO<sub>2</sub> from Aneka Gas Industri in Natar-Lampung Selatan was made with concentration of 15% in air. The variables was the flow rates of the absorbent of 1, 2, and 3 l/min for both absorbents.

#### *Experimental set-up and Procedure*

Figure 1 shows the experimental schematic diagram for chemical absorption.

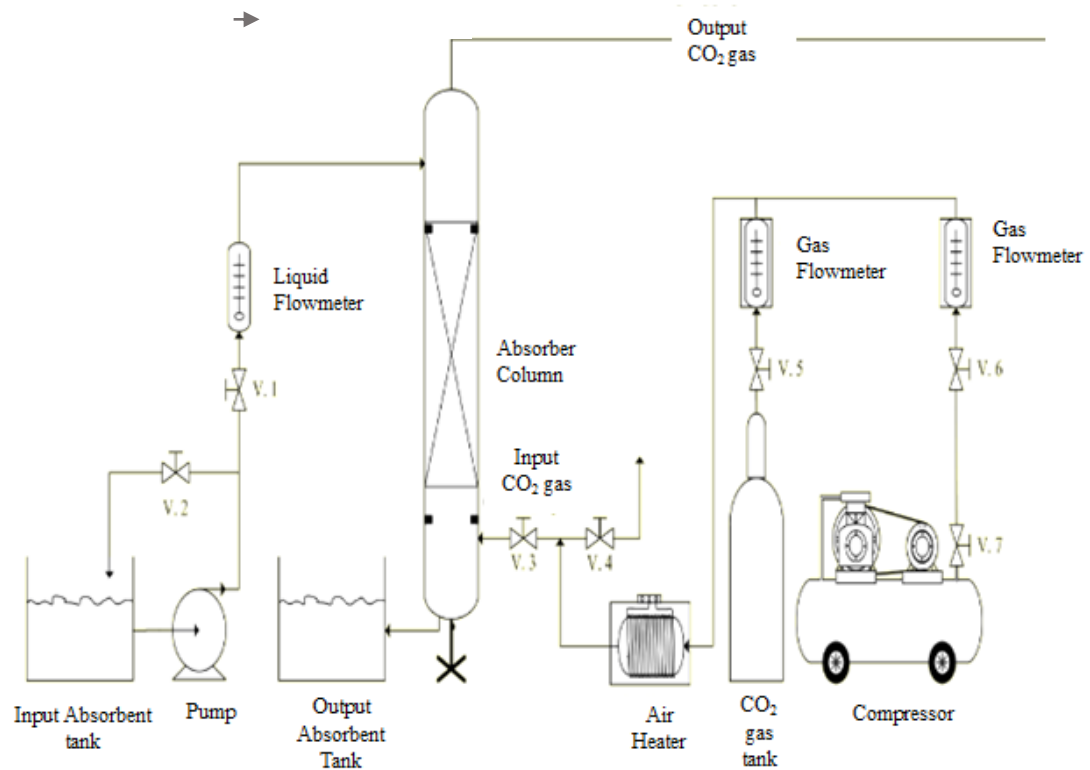

Fig. 1. Schematic of CO<sub>2</sub> absorption tool setting

Fig. 1. Schematic of CO<sub>2</sub> absorption tool setting

The absorbent was pumped into to the top of the packed column as setting volumetric flow rates (1,2,3 l/min). In the same time, the mixture of 15% CO<sub>2</sub>-air was fed at constant flow rate of 1 l/min and contacted counter-currently with the absorbent. Input gas mixture temperature was set to 50 °C. The operation was applied until steady state condition was obtained. The output gas of the packed column was fed into the foto-bioreactor for biological absorption using microalgae. Gas sampling was applied using sampling bag and injected it into CO<sub>2</sub> analyser (2014-AT Gas Chromatography Picture /SIMADZU Corp 08128).

## 2.2 Biological Absorption

Foto-bioreactor was filled with 2 liter culture of microalgae which was cultured for 6 days. The microalgae was then cultivated after 6 days. In the same time, the concentration of the output gas of the packed column was analyzed and the temperature was also measured. *Nannochloropsis oculata* and *Tetraselmis chuii* were obtained from The Laboratory of Mariculture Development, Lampung, Indonesia. They were cultured as explained above. After the cultivation, the microalgae was extracted in a soxhlet using chloroform: methanol and n-hexane as solvent (Purba, 2000). As a result, algal oil was obtained. The alga oil was converted into methyl ester using sodium hydroxide in transesterification process with sulfuric acid as a catalyst.

## 3. RESULTS AND DISCUSSION

### 3.1 Chemical Absorption

#### The Effect of Absorbent Flow Rates on CO<sub>2</sub> Absorption

The effect of NaOH Flow Rate on CO<sub>2</sub> Absorption is shown in Figure 4.

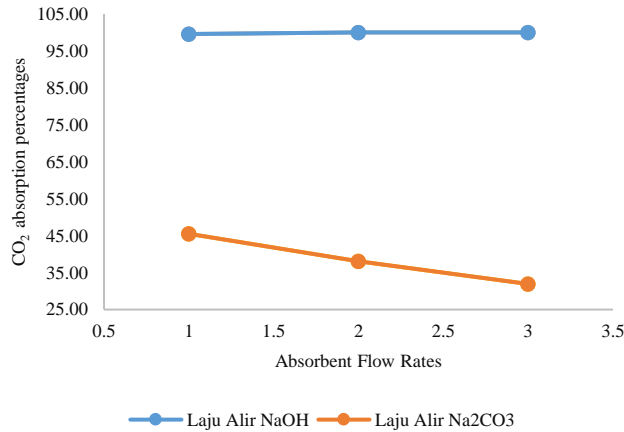

Figure 4. The effect of flow rates on the percentage of CO<sub>2</sub> absorption

As can be seen from Figure 4, the absorption of CO<sub>2</sub> by NaOH is much greater than that of by Na<sub>2</sub>CO<sub>3</sub>. However, both absorbents gives different trend. As for NaOH, the higher the flow rates the higher the percentage of absorption. On the opposite, as for Na<sub>2</sub>CO<sub>3</sub>, increasing the flow rates of absorbent decreasing the percentage of absorption.

As for NaOH, the absorption of CO<sub>2</sub> using NaOH increases with increasing flow rate is due to the increasing the flow rate means increasing the availability of absorbent for CO<sub>2</sub> to dissolve as well as to react. This is in accordance with research by Said and Pamungkas (2012) about the effect of flow rate of CO<sub>2</sub> gas absorption. In the study, it was described that an increase in flow rate can increase the rate of absorption in the gas because the increase of gas flow rate will increase the value of gas mass transfer coefficient. The higher the value of mass transfer coefficient of the gas the higher the liquid absorption capacity of the gas. On the other hand, the absorption of CO<sub>2</sub> using Na<sub>2</sub>CO<sub>3</sub> shows that . increasing the flow rates of absorbent decreasing the percentage of absorption.

#### The Effect of Absorbent Flow Rate on output gas temperature

The effect of flow rates on output gas temperature is shown in Figure 5. As can be seen form the figure, the higher the flow rates the lower the percentage of output gas temperature. This means that the higher the flow rates the gas output temperature is increasing. Higher flow rates was expected to lower the gasoutput temperature, however the results show the opposite. This is because the higher flow rates means shorter contact time with the gas. Therefore, the gas outlet temperature is higher with higher flow rates than that of lower flow rates.

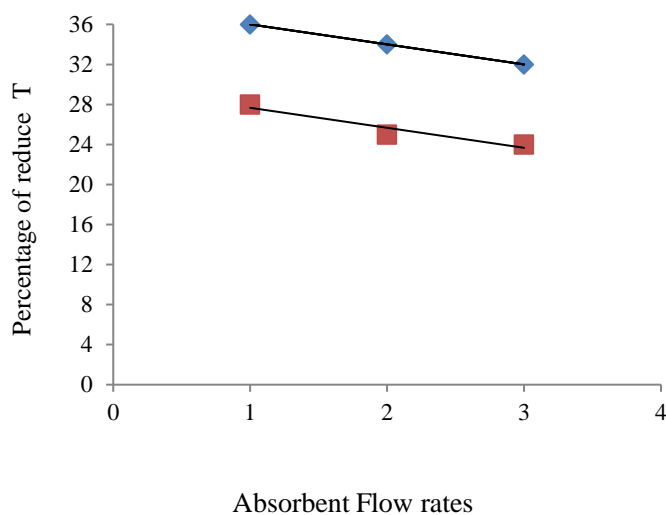

Fig. 5. The Effect of Absorbent Flow Rate on the percentage of reduce output T

- *Extraction of microalgal oil*

The lipids content or microalgal oil was extracted from microalgae in a soxhlet and show the results in Tabel 1.

TABLE 1

LIPID CONTENT EXTRACTED FROM MICROALGAE

Run	Nannochloropsis oculata	Tetraselmis chuii
I	11.0%	10.3%
II	13.0%	10.0%
III	12.5%	10.0%

Cultivation and harvesting processes affect the difference in the lipid. The culture was evaporated under vacuum to release the solvent using rotary evaporator. Then, the oil was obtained. It can be seen from the table that the oil extracted from *N. oculata* is much more than the oil from *T. chuii*.

The algal oil was converted into methyl ester by means of transesterification. The reaction occurs in two stages, they are esterification and transesterification. Then, the oil produced from each algal species was mixed with a mixture of catalyst and methanol with stirring. Esterification must be carried out due to the high content of fatty acid, that is more than 5%. A Certain amount of algal biomass of each species was reacted methyl ester.

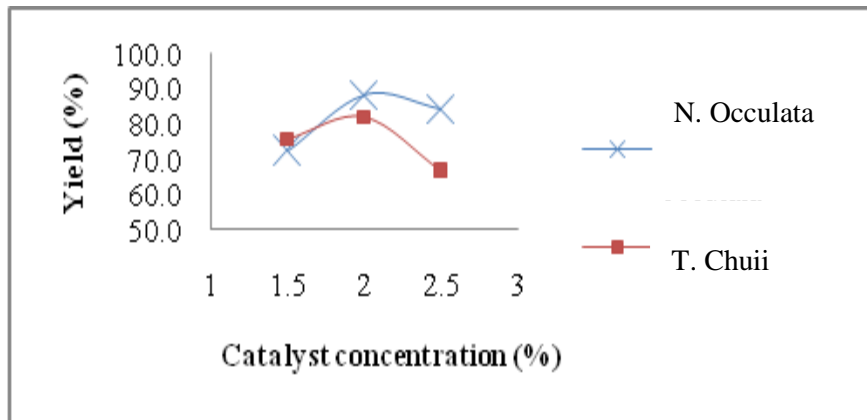

Fig. 9. The effect of catalyst concentration on yield of N. oculata and T. chuii

It can be seen from Figure 9, the yield of methyl ester increase with increasing of catalyst concentration up to 2,0%. The concentration of catalyst in this state is able to optimally break the bond on lipid and exchange with methanol, thus forming FAME and glycerol. The mechanism of reaction can be seen from the picture below:

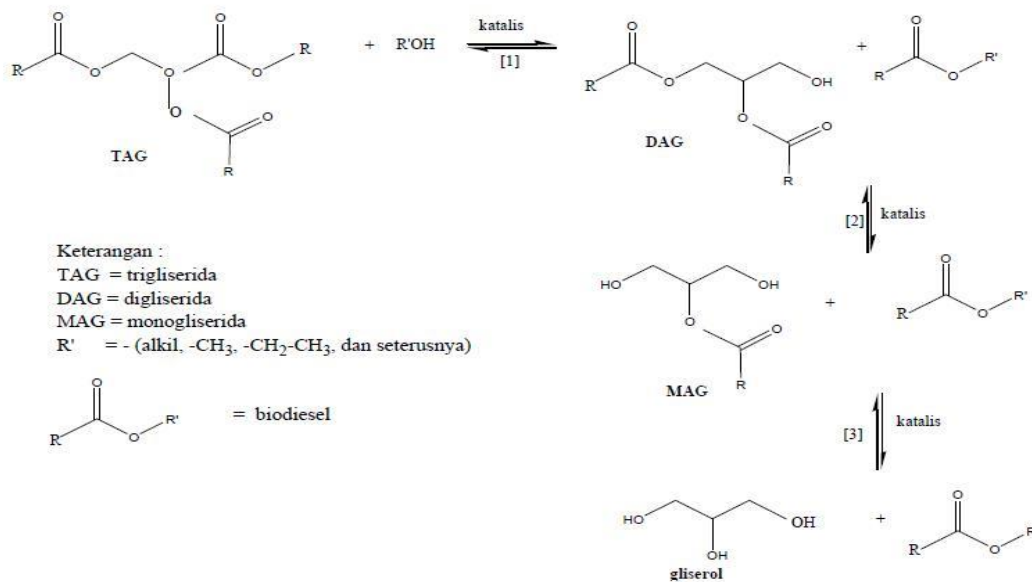

Fig. 10. The mechanism of transesterification reaction with base catalyst (Singh,2010)

It can be seen from Fog. 10 that the mechanism of the transesterification reaction takes 2 steps. The first step, NaOH catalyst will bind to alcohol and wait for the contact with triglycerides. After contacting between alcohol and triglycerides, the Na<sup>+</sup> ions help break the bond contained triglycerides. The disconnected ties react with alcohol and Na<sup>+</sup> ions back to form a compound NaOH.

It also occurs in the second step, in order to obtain the compound of alkyl esters (biodiesel). In the third Step, H<sup>+</sup> ions produced from the break up of alcohol will bind to O=, thus forming glycerol. At a concentration of 1.5% catalyst, methyl ester produced is minimum. When insufficient amount of catalyst is available, the catalyst is not able to optimally promote the lipid break the bond, so the reaction is slow. It takes a little longer to achieve optimum yield.

The highest yield in both microalgae is obtained in the catalyst concentration of 2%, that is 88.5% in microalgae *N. oculata* and 82.3% in microalgae *T. chuii*. Maximum yield of FAME obtained from *N. oculata* is slightly higher than that of *T. chuii*.

#### Characterisation of biodiesel by GC-MS

The biodiesel produced from *N. oculata* and *T. chuii* were analyzed and compared with standards of fatty acids and methyl ester by gas chromatography analyzer. Based on the figure below, there are two peaks that indicate the presence of methyl ester component on both microalgae. Figure 11 shows the result of GC-MS analysis from *N. oculata*.

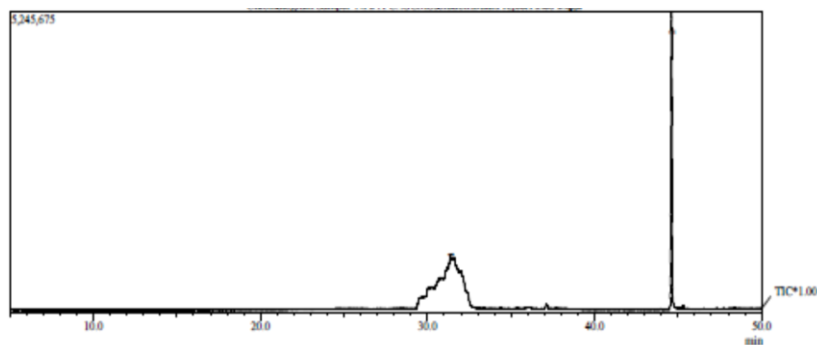

Fig. 11. GC-MS result for *Nannochloropsis oculata* FAME

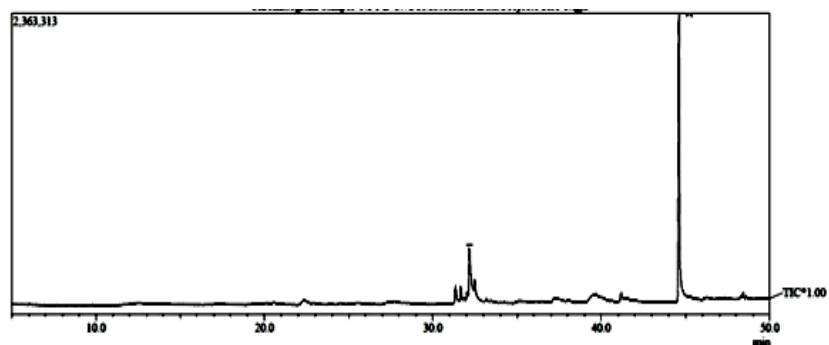

Fig. 12. GC-MS result for *Tetraselmis chuii* FAME

The results indicate that the peak at R. time 31.390 corresponding to the presence of undecanoic acid methyl ester by 55.42% and at R. time 44.620 corresponding to the presence of glyceryl - 1,2 - isopropylidene - 3 - laurin by 44.58%.



The GC-MS analysis result of *Tetraselmis chuii* methyl ester is shown in Figure 12. The first peak appeared at R. time 32.165 minutes. Based on the data bank of methyl ester, it shows that the peak is dodecanoic acid methyl ester by 18.42%. The second peak that appeared at the time R. 44.750 minutes corresponding to the presence of palmitic acid methyl ester by 81.58%.

#### **4. CONCLUSIONS**

The absorption of CO<sub>2</sub> by NaOH is greater when compared with that of Na<sub>2</sub>CO<sub>3</sub>. This is because the solubility and reaction rate of CO<sub>2</sub> in or with each NaOH and Na<sub>2</sub>CO<sub>3</sub> is different. The absorption of CO<sub>2</sub> with NaOH increases with increasing flow rate and the opposite is for Na<sub>2</sub>CO<sub>3</sub>. Extracted oil was transesterified to biodiesel using sodium hydroxide as a catalyst. Both of microalgae obtained maximum yield at 2% catalyst concentration. *Nannochloropsis oculata* gives the highest yield that is 88.5%. The highest content of methyl ester from *Nannochloropsis oculata* is undecanoic acid methyl ester by 55.42% and the result from *Tetraselmis chuii* is palmitic acid methyl ester by 81.58%.

#### **ACKNOWLEDGEMENT**

Elida Purba is in the Chemical Engineering Departement, Universitas Lampung, Bandar Lampung 35145, Indonesia (corresponding author to provide phone: 0721-770844; e-mail: [elida\\_purba@eng.unila.ac.id](mailto:elida_purba@eng.unila.ac.id)). Elida Purba acknowledges government funding as research grant via Kemenristekdikti, Indonesia

## REFERENCES

- Cundari, L.; Selpiana; Radian, Bobby; dan Zaidan, Achmad. 2014. *Pengaruh Penambahan ( $H_3BO_3$ ) pada Larutan  $Na_2CO_3$  Terhadap Absorpsi  $CO_2$  dalam Biogas Menggunakan Spray Column*. Jurusan Teknik Kimia, Fakultas Teknik, Universitas Sriwijaya. Palembang
- D. A. El-Maksoud, M. A. El-Shafie, N. N. Saad, R. M. Salah, S. S. Ahmed, "Production of Biodiesel from Algae," B.Sc. thesis, Dept. Chem. Eng., Cairo Univ., Cairo, Egypt, 2012.
- E. Purba, D. Saragih, K. Ranti, "Ekstraksi Minyak Alga dari Alga Kering *Nannochloropsis oculata* dan *Tetraselmis chuii* Menggunakan Etanol dan N-Heksana," *Proceedings of the 3<sup>rd</sup> National Seminar on Science and Technology*, Lampung Univ., Bandar Lampung, Indonesia, 201.
- Hasnan A, M., Najib, Prima, P., Kumaeti, N., dan A. Aji Hapsoro. 2012. *Studi Pengaruh Variabel Laju Alir NaOH dalam Proses Absorpsi Gas  $CO_2$* . Jurusan Teknik Kimia, Fakultas Teknik, Universitas Diponegoro. Semarang
- Javed, K., H., Mahmud, T., and Purba, E., 2010. "The  $CO_2$  Capture on a High-Intensity Vortex Spray Scrubber". *Chemical Engineering Journal*, Vol. 162, pp. 448-456.
- M. Masykuri, "Pengaruh Komposisi Pelarut Campuran Kloroform – Metanol dan Rasio Padatan Terhadap Pelarut pada Ekstraksi Minyak Alga *Nannochloropsis oculata*," , Lampung Univ., Bandar Lampung, Indonesia, 2012.
- Ndīritū, H.M.; Kībicho, K; dan Gathitū. 2013. *Effect of Heating on the absorption of  $CO_2$  as Greenhouse Gas in Structured Packed Scrubber*. Department of Mechanical Engineering. Jomo Kenyatta University of Agriculture and Technology (JKUAT)
- Purba, E., Mahmud, T., and Javed, K.H., *Enhancement of Mass Transfer in a Spray Tower Using Swirling Gas Flow*. *Jurnal International Chemical Engineering Research and Design*, Volume 84, Issue 6, Hal 448-446. Juni 2006
- Said, Imam Noor; Saputri. Irma; Pamungkas M. Dawam. 2014. *Absorpsi Gas Karbondioksida Dengan Larutan NaOH*. Jurusan Teknik Kimia, Fakultas Teknik, Universitas Diponegoro
- S. Ketaren, "Pengantar Teknologi Minyak dan Lemak Pangan," UI-Press, Jakarta, Indonesia, 1986.
- S. P. Singh, D. Singh, "Biodiesel Production Through The Use of Different Sources and Characterization of Oils and Their Esther and Substitute of Diesel," *Renewable and Sustainable Energy Reviews 14*, 2010, pp. 200-216.
- X.Ma, "Biodiesel Production from Algae through In Situ Transesterifikasi Technology," M.Sc. thesis, Minnesota Univ., Minnesota, USA, 2012.
- Y. Christi, "Biodiesel from Microalgae," *Biotechnology Advances 25*, 2007, pp. 294-306.