



This work is licensed under

a [Creative Commons Attribution-NonCommercial 4.0 International License](https://creativecommons.org/licenses/by-nc/4.0/).

## Development of Simple Boyle's Law Practicum Equipment to Train Science Process Skills

Luqman Hakim<sup>1</sup>, Kartini Herlina<sup>2\*)</sup>, Anggreini<sup>3</sup>, Abdurrahman<sup>4</sup>  
University of Lampung, Indonesia<sup>1,2,3,4</sup>

\*)Corresponding E-mail: [kkartini.herlina@gmail.com](mailto:kkartini.herlina@gmail.com)

Received: February 23<sup>rd</sup>, 2024. Revised: August 2<sup>nd</sup>, 2024. Accepted: August 6<sup>th</sup>, 2024

### Keywords :

Boyle's Law; Science Process Skills; Blynk; Microcontroller ESP32; BMP280

### ABSTRACT

*This research aims to develop a simple Boyle's law practicum equipment that can be used to train science process skills in learning the concept of Boyle's law in schools. This research uses the Design and Development Research development model adapted from Richey and Klien with stages namely analyze, design, development, and evaluation.. The practicum equipment developed is declared feasible to use if it has passed the validity test and practicality assessment.. The validity test obtained a percentage of 88% with a very valid category.. Practicality assessment is represented through teacher perception, students response, and analysis of science process skills.. The results of teacher perception obtained a percentage of 83% with a very practical category. The results of students' responses obtained a percentage of 90% with a very practical category. The analysis of science process skills obtained a percentage of 87% with a very good category. Based on the validity test and practicality assessment that has been carried out, it can be concluded that the practicum equipment developed is suitable to be applied to train science process skills in learning the concept of Boyle's law in schools.*

## INTRODUCTION

The development of technology in the 21<sup>st</sup> century has affected every field of life. One of them is in the field of education, whose main activity is learning. Learning applied in the 21<sup>st</sup> century does not only rely on knowledge but skills also play a role. Students must understand the skills that must be possessed in 21<sup>st</sup> century learning or commonly known as 4C skills [1]. 4C skills consist of *critical thinking, communication, collaboration, and creativity*. In addition, 21<sup>st</sup> century learning provides space for students to be actively involved in learning. This shows that 21<sup>st</sup> century learning has changed the learning approach from teacher-centered learning to student-centered learning [2]. In line with what was conveyed by Siagian et al [3], the physics learning process should emphasize on providing direct experience to develop the competence of students so that students can better understand the surrounding nature scientifically. One of the student-centered learning is learning that trains science process skills in it.

Science process skills are skills that essentially include all the skills and abilities that students already have to gain new knowledge based on the phenomena they encounter [4]. Gagne [5] divides science process skills into two, namely basic and integrated science process skills. Beaumont Walters & Soyibo [6] explains that basic science process skills provide an intellectual foundation in science such as providing a description of the object being observed. Integrated science process skills can be said to be skills in conducting experiments or solving problems. Science process skills can help students in achieving higher order thinking skills, as well as providing meaningful learning experiences [7]. Therefore, science process skills are needed to know how to obtain scientific concepts [8]. These skills are not innate skills that students have so they need to be practiced through the learning process [9]. Therefore, this skill can be trained with scientific-based activities, one of which is through practicum activities [10]. To carry out practicum activities, practicum equipment is needed [11].

Practicum equipment is a tool that can be absorbed by the eyes and ears with the aim of helping educators to make the learning process more effective and efficient [12]. The use of practicum equipment can increase the effectiveness of learning by involving various senses [13]. Practicum equipment is also expected to be able to stimulate imagination and be able to compare with objects that exist in everyday life, and also be able to analyze the characteristics of the objects they found [14]. This makes the use of practicum equipment in the science learning process can make it easier for students to understand science concepts [15].

The preliminary analysis questionnaire distributed by researchers to 50 students in 10 different schools in Lampung, obtained information that 74% of students had difficulty in understanding the concept of Boyle's law. The difficulty is due to the abstract concept of Boyle's law, the difficulty of students in obtaining illustrations of Boyle's law, and the absence of direct learning experience. As many as 60% of students have never done practicum in learning the concept of Boyle's law. The preliminary analysis questionnaire was also addressed to 10 teachers in the same school as the preliminary analysis questionnaire for students. Through the preliminary analysis questionnaire, the teacher expressed the reason for not holding a practicum, namely due to the unavailability of practicum equipment. This is also one of the reasons why science process skills have not been optimally trained.

The unavailability of practicum equipment to support learning the concept of Boyle's law which is abstract and can also train students' science process skills is the main foundation for researchers in developing Boyle's law practicum equipment to train science process skills. Practicum equipment plays an important role in learning the concept of Boyle's law which is abstract in accordance with the statement of Chou et al [16] which states that practicum equipment consisting of tangible objects is very helpful in learning abstract concepts in science because it allows students to visualize these concepts. This is also supported by the statement of Wijaya et al [17] which states that practicum equipment is considered effective and appropriate for teachers to explain abstract physics concepts. In use, practicum equipment can also train science process skills [18].

## METHOD

This development research uses the Design and Development Research (DDR) development model adapted from Richey & Klein [19]. This development model has 4 research stage procedures namely analysis, design, development, and evaluation. The analysis stage is carried out by gathering information related to learning the concept of Boyle's law through a preliminary analysis questionnaire filled out by teachers and students. Furthermore, at the design stage, the information that has been obtained through the preliminary analysis questionnaire is continued by making a practicum equipment's design that is suitable with the needs of teachers and students. The following is the design of the developed practicum equipment.

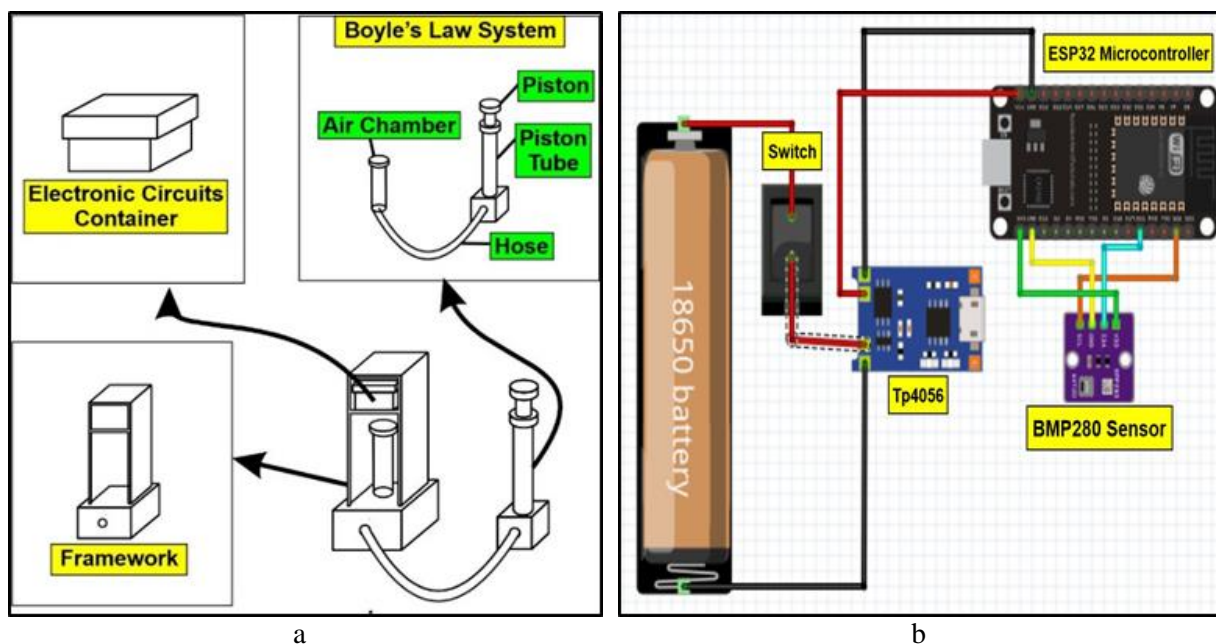

**Fig 1.** a) Practicum Equipments Design. b) Electronic Circuit Schematic

Figure 1.a) shows design of practicum equipment which mainly consists of three parts, namely framework, Boyle's law system, and electronic circuit container. Framework is useful for placing the air chamber and electronic circuit container. Boyle's law system is where the Boyle's law phenomenon occurs and in this system there is a BMP280 sensor connected to an electronic circuit. Electronic circuit container is useful for placing electronic circuits. The circuit consists of several components including BMP280 sensor, ESP32 microcontroller, switch, TP4056, and 18650 battery. However, BMP280 sensor is used to measure the pressure in the Boyle's law system. The sensor was chosen because it is affordable and widely available in the market. The specifications possessed by the BMP280 sensor are also quite capable including measuring pressure up to 1100 hPa, can operate at voltage of 1.6 V to 3.6 V, and has small dimensions of 11 x 15 mm. The results of the pressure measurements taken by the BMP280 sensor to the gas in the Boyle's law system are sent to the web server with the help of the ESP32 microcontroller so that they can be accessed via the internet. The power in this electronic circuit is supplied by 18650 battery so that it can operate even though it is not connected to a laptop. The use of practicum equipment for a long time can cause the 18650 battery to run out of power. However, this can be overcome by including a TP4056 in the electronic circuit to recharge the 18650 battery. In addition, to save power in electronic circuits, a switch is also installed which is useful for breaking the circuit current when the practicum equipment is not being used. As shown in Figure 1.b), each pin on components in the electronic circuit is connected to each other through a jumper cable starting from an 18650 battery. This battery has two poles, namely the positive pole and the negative pole, each of which is connected to pin B+ and pin OUT+ on the TP4056 to drain the electric current. The current is then forwarded by the TP4056 through pin B- and pin OUT- which are respectively connected to the Vin and GND pins on the ESP32 microcontroller so that it can operate. The microcontroller is also connected to the BMP280 sensor through pin D21, pin D22, pin 3V3, and pin GND which are respectively connected to pin SDA, pin SCL, pin VCC, and pin GND on the BMP280 sensor.

Furthermore, at the development stage, practical equipment is made based on the design that has been made at the design stage. The making of this simple Boyle's law practicum equipment utilizes simple materials such as plywood as a framework and unused food containers as containers for placing electronic circuits. Two injections and a hose were also used to make the Boyle's law system. One of the 60 cc injection is used as an air chamber and connected through a hose to another 120 cc injection and used as a piston. To keep the temperature and the amount of gas constant, the Boyle's law system is made airtight by closing the large hole in the air chamber using a pile of hot glue after the BMP280

sensor is inserted into the air chamber. After the practicum equipment is successfully made, an empirical trial is carried out to see the suitability of the performance of the practicum equipment with the concept of Boyle's law. If it is in accordance with concept of Boyle's law, then validation tests and practicality assessments are carried out which are represented through teacher perceptions, student responses, and analysis of science process skills. The evaluation stage in this development research consists of two types, namely formative evaluation and summative evaluation. This formative evaluation is carried out at each stage of the development procedure, namely at the analysis, planning, development, and implementation stages. The results of this formative evaluation are used as revision material. Meanwhile, summative evaluation was carried out after the results of the practicum equipment practicality were obtained. The summative evaluation was conducted to determine the achievement of the research process.

## RESULTS AND DISCUSSIONS

### *Results*

#### *1. Product*



**Fig 2.** *Product Realization of Practicum Equipments*

Figure 2 shows the realization of Boyle's law practicum equipment developed. The realization of the Boyle's law practicum equipment is in accordance with the design described in the methodology, Boyle's law practicum equipment consists of a framework, a boyle's law system, and an electronic circuit container. Boyle's law system consists of piston and piston tube, hose, and air chamber.

#### *2. Calibration*

Sensor calibration on the practicum equipment is carried out by comparing data in the form of ADC values generated by the BMP280 sensor on the practicum equipment with data from the measurement of standard measuring instruments which in this study used a digital manometer. This calibration is useful for adjusting the BMP280 sensor work system on the practicum equipment with the standard measuring instrument work system. The measurement data can be seen in the table 1.

**Table 1.** BMP 280 Sensor ADC Value and Standard Measurement Tool Value

Sensor ADC Value	Standard Measurement Tool Value (kPa)
116041.78	21
116096.88	21
116125.25	21
116142.15	21
116146.84	21
126300.02	29
126304.88	29
126317.59	29
126324.39	29
126325.7	29
137902.89	41
137934.27	41
137939.06	41
137939.45	41
137955.09	41
153746.52	66
153758.09	66
153789.52	66
153802.81	66
153813.08	66

The measurement data that has been obtained is then processed using Microsoft Excel to visualize it in graphical form and also to find the regression equation and  $R^2$  as shown in Figure below.

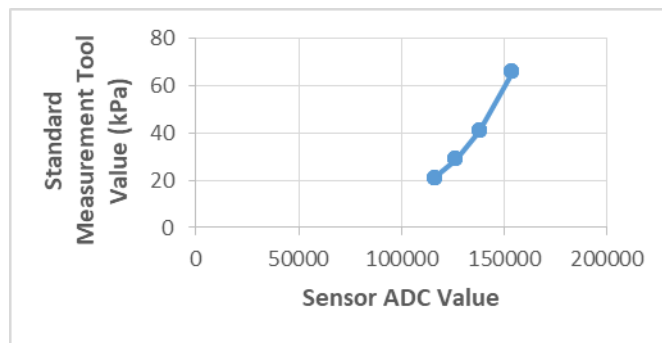

**Fig 3.** Regression Equation and  $R^2$

Based on Figure 3, the regression equation is  $y = 0.0012x - 120.87$ . The equation is substituted into the BMP280 sensor program and uploaded again so that the sensor's working system adjusts to the standard measuring instrument. Meanwhile, the  $R^2$  value or also known as the coefficient of determination in sensor calibration is useful for measuring the suitability of the regression equation. The value of  $R^2$  lies from 0 to 1 and the suitability is said to be better if  $R^2$  is closer to 1. In this BMP280 sensor calibration, the  $R^2$  value as shown in Figure 3 is 0.9757. It shows the suitability of the regression equation is very good.

### 3. Empirical Test

The empirical test produces a pressure value measured through the BMP280 sensor and displayed through the blynk platform and a volume value that can be known from the scale of the piston tube through the piston shift. In this empirical test, pressure is the independent variable and volume is the dependent variable. Results of the empirical test that have been carried out can be seen in the table 2.

**Table 2.** Result of Empirical Test

Attempt to	Pressure	Volume	Inverse Volume (1/V)
1	2 kPa	146 cc	0.007
2	4 kPa	142 cc	0.007
3	8 kPa	136 cc	0.007
4	16 kPa	126 cc	0.008
5	32 kPa	112 cc	0.009

#### 4. Validity Test

The validity test was conducted by four experts who are competent in their fields. This test was carried out using a validity test questionnaire consisting of eighteen questions and grouped into several aspects, namely material, usefulness in science process skills, illustrations, and quality and appearance of practicum equipment. Results of the validity test that has been carried out can be seen in the table 3.

**Table 3.** Validity Test Results

Item	Rated Aspect	Average Validator Score	Qualitative Statement
1.	Material	83%	Very High Validity
2.	Usefulness pada Science Process Skills	86%	Very High Validity
3.	Ilustrations	90%	Very High Validity
4.	Quality and Appearance of Practicum Equipment	89%	Very High Validity
<b>Final Average</b>		<b>87%</b>	<b>Very High Validity</b>

#### 5. Teacher Perceptions

Teacher perceptions were obtained through a teacher perception questionnaire filled out by fifteen teachers from different schools. The distribution of the teacher perception questionnaire aims to determine the teacher's perception of the practicality of the developed simple Boyle's law practicum equipment when used in the learning process. This questionnaire consists of four aspects, namely usefulness, ease of use, ease of learning, and satisfaction. Results of teacher perceptions can be seen in the table 4.

**Table 4.** Teacher Perceptions Results

Item	Rated Aspect	Average Validator Score	Qualitative Statement
1.	Usefulness	86%	Very Good
2.	Ease of Use	78%	Good
3.	Ease of Learning	79%	Good
4.	Satisfaction	88%	Very Good
<b>Final Average</b>		<b>83%</b>	<b>Very Good</b>

#### 6. Students Response

Students responses were obtained through a student response questionnaire filled out by twelve new students of the Physics Education Study Program. The distribution of the students response questionnaire aims to find out the student's opinions about the practicality of the developed simple Boyle's law practicum equipment. This questionnaire consists of four aspects, namely convenience, motivation, usefulness, and attractiveness. Results of students responses can be seen in the table 5.

**Table 5.** Student's Response Results

Item	Rated Aspect	Average Validator Score	Qualitative Statement
1.	Ease	88%	Very Good
2.	Motivation	92%	Very Good
3.	Attractiveness	92%	Very Good
4.	Usability	88%	Very Good
<b>Final Average</b>		<b>90%</b>	<b>Very Good</b>

7. *Analysis of Science Process Skills*

In the analysis of science process skills, a science process skills analysis sheet was used which was filled in by the researcher as an observer by observing students in using practicum equipment. The analysis was carried out on twelve new students of the Physics Education Study Program who in this case had the role of students. Results of the analysis of science process skills can be seen in the table 6.

**Table 6.** Science Process Skills Analysis Results

Item	Rated Aspect	Average Validator Score	Qualitative Statement
1	Observing	96%	Very Good
2	Controlling Variables	89%	Very Good
3	Hypothesizing	90%	Very Good
4	Experimentation	89%	Very Good
5	Communicating	78%	Good
6	Data Interpreting	83%	Very Good
<b>Final Average</b>		<b>87%</b>	<b>Very Good</b>

*Discussion*

The development of practicum equipment is carried out in accordance with the design that has been made at the design stage. In this development stage, the product is produced in the form of a simple Boyle's law practicum equipment as can be seen in Figure 2. In the development stage, empirical testing, validity testing, and practicality assessment are also carried out through teacher's perceptions, student's responses, and analysis of science process skills.

1. *Experiment Data*

Experimental data about the effect of pressure on volume which can be seen in table 2 is then processed using Microsoft Excel to be visualized in the form of a graph which can be seen in the following figure.

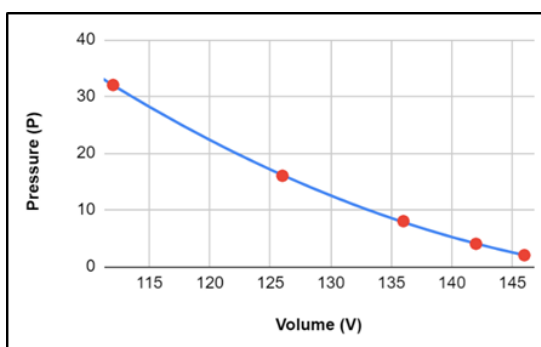

**Fig 4.** Pressure vs Volume Graph

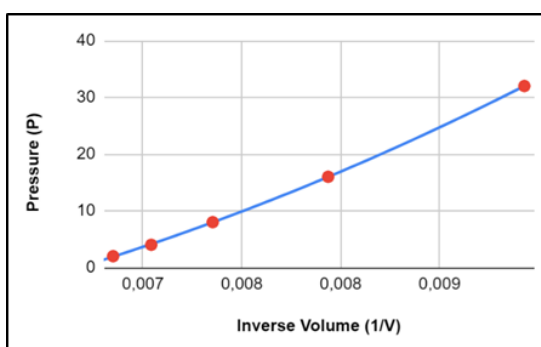

**Fig 5.** Pressure vs Inverse Volume Graph

The graph in figure 4 shows that as volume increases, pressure decreases. It is further validated by the graph in figure 5 which shows the relationship between pressure and the inverse of volume is indeed a linear function. It is in accordance with Boyle's law which states that the volume of a gas is inversely proportional to the pressure it receives, at constant temperature [20].

### 2. *Validity Test*

Based on the data from the validity test results as shown in Table 3, the validity test obtained a final average score percentage of 88%. The obtained score makes the practicum equipment included in the very high validity category so that it can be continued in the next process, namely the practicality assessment. This also shows that the practicum equipment can be used in learning the concept of Boyle's law as a learning medium that can help students learn abstract concepts in science because it allows students to visualize the concept, as researched by Chou et al [16].

In addition to providing an assessment of the validity of the practicum equipment, the validator also provided suggestions for improvements to the practicum equipment that the researcher had followed up on. Suggestions that were followed up by researchers included recalibrating the BMP280 sensor to adjust its units to international units, providing a holder for the piston tube so that it can stand upright, re-scaling the piston tube so that the volume can be calculated thoroughly, and tidying up the appearance of the practicum equipment.

### 3. *Teacher Perceptions*

The results of teacher perceptions as shown in Table 4, obtained a final average percentage of 83% with a very good category. Thus, it can be said that the practicum equipment is practical in helping teachers teach the concept of Boyle's law at school. This is accordance with Sudjana's statement [12] which states that the practicum equipment is a tool that can be absorbed by the eyes and ears with the aim of helping educators to make the learning process more effective and efficient. The highest assessment based on teacher perceptions was obtained in the satisfaction aspect, whose final average percentage was 88% with a very good category. In use, the Boyle's law practicum equipment is considered to have functioned properly so that it can be used to take experimental data and produce data analysis in accordance with the concept of Boyle's law. This is accordance with Afriyanto's statement [21] which states that one of the criteria for the feasibility of physics practicum equipment is that the practicum equipment must be in accordance with the concept of physics.

### 4. *Students Response*

Based on the results of the distribution of student response questionnaires conducted on 12 new students of the Physics Education Study Program as shown in table 5, obtained an average final score percentage of 90% with a very good category. Thus, it can be concluded that students feel that the practicum equipment developed by researchers is practical in helping to understand the concept of Boyle's law in physics learning at school. This is accordance with Arsyad's statement [15] which states that the use of practicum equipment in the science learning process can make it easier for students to understand science concepts. The highest assessment in the students response questionnaire was obtained in the motivation aspect and the attractiveness aspect, each of which obtained a final average score percentage of 92% with a very practical category. This shows that the practicum equipment that have been developed can motivate students to learn the concept of Boyle's law and have a very good attractiveness that makes it attractive. Accordance with the statement of Suprayanti et al [22] which states that practicum equipment must be made as good as possible, simple, interesting to observe, and encourage students to develop curiosity so that it is hoped that student's learning motivation will increase.

### 5. *Analysis of Science Process Skills*

Based on the results of the researchers' analysis of twelve new students of the Physics Education Study Program as shown in table 6, the percentage of the average final score of the 6 indicators used in this study was 87% with a very good category. Thus, the practicum equipment is considered to be able to train students' science process skills, accordance with research conducted by Dewantara et al [18].





*Fig 6. Students Try to Use Practicum Equipment*

The Boyle's law practicum equipment developed can train science process skills on six of the ten indicators according to Chiappetta & Koballa [23] namely observing, controlling variables, hypothesizing, experimentation, communicating, and interpreting data. The observing indicator is seen when students observe a video about the phenomenon of Boyle's law as a stimulus. The controlling variables indicator is shown when students change the pressure variable by pressing the piston on the practicum equipment. The hypothesizing indicator is shown when students make hypotheses about how the pressure applied to the system affects the volume data produced. The hypothesis that has been made is tested through experiments by taking pressure and volume data repeatedly with different sizes. This activity shows the experimentation indicator. The communicating indicator is shown when students visualize the pressure and volume data that has been obtained in the form of tables and graphs. The interpreting data indicator is shown when learners interpret and draw conclusions based on visualized tables and graphs.

## CONCLUSION AND SUGGESTION

This simple practicum equipment can be used as a tool in visualizing the concept of Boyle's law. The design of this practicum equipment is not only to help teachers explain the concept of Boyle's law, but also to be able to train students' science process skills through direct experiments. Some indicators that can be raised when using this Boyle's law practicum equipment are observing, controlling variables, hypothesizing, experimentation, communicating, and interpreting data.

The development of this practicum equipment is expected to help overcome the problem of students' learning difficulties in the concept of Boyle's law. The materials used in making this practicum equipment also use simple materials and are combined with several electronic devices. This is intended to reduce costs and make it easier for teachers or educators who want to design similar tools in the future.

In the next research, the design of the practicum equipment should be further streamlined so that it is easy to carry around and the use of cables connecting the BMP280 sensor and the ESP 32 microcontroller is more streamlined by using jumper cables that are 30 cm long so that it does not look crowded.

## REFERENCES

- [1] Mardhiyah, R. H., Aldriani, S. N. F., Chitta, F., & Zulfikar, M. R. (2021). Pentingnya keterampilan belajar di abad 21 sebagai tuntutan dalam pengembangan sumber daya manusia. *Lectura: Jurnal Pendidikan*, 12(1), 29-40.

- [2] Redhana, I. W. (2019). Mengembangkan keterampilan abad ke-21 dalam pembelajaran kimia. *Jurnal inovasi pendidikan kimia*, 13(1).
- [3] Siagian, C., Manalu, A., & Siahaan, F. E. (2024). Pengaruh Model Pembelajaran Problem Based Learning Terhadap Keterampilan Proses Sains Fisika Siswa Sma Negeri 5 Pematang Siantar. *Innovative: Journal Of Social Science Research*, 4(1), 2740-2753.
- [4] Deratama, D., Surahman, E., & Fitriani, R. (2020). Pengaruh model problem based learning terhadap keterampilan proses sains dasar dan hasil belajar siswa pada konsep sistem pencernaan makanan pada manusia. *Assimilation: Indonesian Journal of Biology Education*, 3(2), 46-50.
- [5] Gagne, R. (1965). *The Psychological Bases of Science: A Process Approach*. American Assoc. for the Advancement of Science.
- [6] Beaumont-Walters, Y., & Soyibo, K. (2001). An analysis of high school students' performance on five integrated science process skills. *Research in Science & Technological Education*, 19(2), 133-145.
- [7] Tilakaratne, C. T. K., & Ekanayake, T. M. S. S. K. Y. (2017). Achievement level of science process skills of junior secondary students: Based on a sample of grade six and seven students from Sri Lanka. *International journal of environmental & science education*, 12(9), 2089-2108.
- [8] Abd Rauf, R. A., Rasul, M. S., Mans, A. N., Othman, Z., & Lynd, N. (2013). Inculcation of science process skills in a science classroom. *Asian Social Science*, 9(8), 1911-2017.
- [9] Khaeriyah, K., Suryani, D. I., & Taufik, A. N. (2022). Pengembangan Lembar Kerja Peserta Didik Berbasis Keterampilan Proses Sains pada Tema Hujan Asam Kelas VII SMP. *PENDIPA Journal of Science Education*, 6(3), 688-694.
- [10] Putri, W. A., & Astalini, A. (2022). Analisis kegiatan praktikum untuk dapat meningkatkan keterampilan proses sains dan kemampuan berpikir kritis. *Edukatif: Jurnal Ilmu Pendidikan*, 4(3), 3361-3368.
- [11] Satria, R. P., & Devi, V. M. (2023). Pengembangan Alat Praktikum Fisika Berbasis Sensor Ultrasonik Berbantuan Aplikasi Delphi. *ORBITA: Jurnal Pendidikan dan Ilmu Fisika*, 9(1), 112-118.
- [12] Sudjana, N. (2021). *Dasar dasar proses belajar mengajar*. Sinar Baru Algensindo.
- [13] Maharani, M., Wati, M., & Hartini, S. (2017). Pengembangan Alat Peraga pada Materi Usaha dan Energi untuk Melatihkan Keterampilan Proses Sains melalui Model Inquiry Discovery Learning (IDL) Terbimbing. *Berkala Ilmiah Pendidikan Fisika*, 5(3), 351-367.
- [14] Suwardi, S., Firmiana, M. E., & Rohayati, R. (2016). Pengaruh penggunaan alat peraga terhadap hasil pembelajaran matematika pada anak usia dini. *Jurnal Al-Azhar Indonesia Seri Humaniora*, 2(4), 297-305.
- [15] Arsyad. (2011). *Media Pembelajaran*. Rajawali Press.
- [16] Chou, Y. C., Yen, H. Y., Yen, H. W., Chao, Y. L., & Huang, Y. H. (2015). The Effectiveness of Teaching Aids for Elementary Students' Renewable Energy Learning and an Analysis of Their Energy Attitude Formation. *International Journal of Environmental and Science Education*, 10(1), 39-49.
- [17] Wijaya, A., Ertikanto, C., Andra, D., & Herlina, K. (2022). Development of Simple Light Diffraction Props Assisted by Tracker Application with Camera Module and Arduino UNO. *JIPF (Jurnal Ilmu Pendidikan Fisika)*, 7(3), 306-315.
- [18] Dewantara, D., & Wati, M. (2019, February). Development of simple machines props to train student's science process skills. In *Journal of Physics: Conference Series* (Vol. 1171, No. 1, p. 012017). IOP Publishing.
- [19] Richey, R. C., & Klein, J. D. (2014). *Design and development research: Methods, strategies, and issues*. Routledge.
- [20] Young, H. D., & Freedman, R. A. (2001). *Fisika Universitas Jilid 1 Edisi Kesepuluh*. Erlangga.
- [21] Afriyanto, E. (2015). Pengembangan media pembelajaran alat peraga pada materi hukum biot savart di SMA Negeri 1 Prambanan Klaten. *Jurnal riset dan kajian pendidikan fisika*, 2(1), 20-24.

- [22] Suprayanti, I., Ayub, S., & Rahayu, S. (2016). Penerapan model discovery learning berbantuan alat peraga sederhana untuk meningkatkan aktivitas dan hasil belajar siswa kelas VII SMPN 5 Jonggat tahun pelajaran 2015/2016. *Jurnal Pendidikan Fisika dan Teknologi*, 2(1), 30-35.
- [23] Collette, A. T., & Chiappetta, E. L. (1984). *Science Instruction in the Middle and Secondary Schools*. The CV Mosby Company, 11830 Westline Industrial Drive, St. Louis, MO 63146.