

PAPER NAME

Cek Plagiasi The Effect of Perceived Organizationa

WORD COUNT

6647 Words

CHARACTER COUNT

38406 Characters

PAGE COUNT

12 Pages

FILE SIZE

717.2KB

SUBMISSION DATE

Jun 13, 2023 10:52 PM GMT+7

REPORT DATE

Jun 13, 2023 10:53 PM GMT+7**● 4% Overall Similarity**

The combined total of all matches, including overlapping sources, for each database.

- 4% Internet database
- 1% Publications database
- Crossref database
- Crossref Posted Content database
- 5% Submitted Works database

● Excluded from Similarity Report

- Bibliographic material
- Quoted material
- Cited material
- Small Matches (Less than 8 words)
- Manually excluded text blocks

The Effect of Perceived Organizational Support and Perceived Supervisor Support on Organizational Change with Agility as a Mediator at PT PLN (PERSERO)

Aldio Fikri Siddik^a, Ayi Ahadiat^b, Keumala Hayati^c

^aPostGraduate Student of the University of Lampung, Bandar Lampung, Indonesia

^bUniversity of Lampung, Bandar Lampung, Indonesia

^cUniversity of Lampung, Bandar Lampung, Indonesia

Abstract

In an organization, change is something that is bound to happen. This change is an important issue in an organization or company. The conditions faced by an organization today are the era of technological change, namely Turbulence, Uncertainty, Novelty, Ambiguity (TUNA) and Volatility, Uncertainty, Complexity, and Ambiguity (VUCA), where this situation requires the organization to be agile and have a learning culture. This study aims to determine the effect of Perceived Organizational Support and Perceived Supervisor Support on Organizational Change with Agility as a Study Mediator at PT PLN (Persero). The sample of this study amounted to 275 employees of PT PLN (Persero). The analytical tool used in this research is Structural Equation Modeling (SEM). The results showed that Perceived Organizational Support and Perceived Supervisor Support affected Agility. Perceived Organizational Support does not affect Organizational Change, while Perceived Supervisor Support does not affect Organizational Change. Furthermore, Agility mediates the effect of Perceived Organizational Support and Perceived Supervisor Support on Organizational Change. This research implies that researchers suggest that PT PLN should pay more attention to its employees, besides that PT PLN is advised to re-evaluate every year on organizational health index surveys, and cultural and cultural surveys. making opportunities for improvement to make actions for improvement in mitigating risks that occur in the future.

Keywords: Perceived Organizational Support; Perceived Supervisor Support; Organizational Change; Agility

Date of Submission: 18-07-2022

Date of Acceptance: 02-08-2022

I. Introduction

In an organization, change is something that is bound to happen. This change is an important issue in an organization or company. The conditions faced by an organization today are the era of technological change, namely Turbulence, Uncertainty, Novelty, Ambiguity (TUNA) and Volatility, Uncertainty, Complexity, and Ambiguity (VUCA), where this situation requires organizations to be agile and have a learning culture so as not to become victims like companies that have gone bankrupt. So the organization is currently experiencing unusual conditions, especially in the current era of TUNA and VUCA. In addition to the conditions of TUNA and VUCA, the organization in 2020 is currently experiencing a great shock, namely the COVID-19 pandemic that attacks all over the world.

Rapid and drastic changes in the industrial sector make organizations face new challenges and, in this case, the formation of agility in an organization is very necessary. Organizational agility is growing significantly as one of the main tools to gain and maintain a competitive advantage in a rapidly changing market environment [1]. Agility is one of the main organizational characteristics sought by business practitioners to remain adaptive and competitive in a volatile environment.

Organizational agility is considered a core competency, competitive advantage, and differentiator that requires strategic thinking, an innovative mindset, taking advantage of change, and the relentless need to adapt and be proactive [2]. Organizational agility is a multidimensional and complex topic and is approached by many researchers from different perspectives. Many researchers have discussed organizational agility [3]; [4]; [5]; [6]; [7]; [8]; [9]; [10] and noted the impact of Agility on an organization by providing managers with valuable insights in dealing with COVID-19.

Today's changes are very fast, taking into account the conditions of TUNA VUCA and Covid-19 in the company's transformation process where these changes are required by agile organizations and employees in dealing with the company. However, from the results of the Change Readiness Index conducted in the Cultural Survey in 2020, it was found that the Corporate Readiness Change Index Per Dimension was the lowest

dimension among the other 4 dimensions. Even though the 83.66% point in the Ability dimension is ready to change, this has become a matter of concern for the company so that this change can still take place following the company's dream. To be successful, it must get support from the organization and supervisor (management) in the change. Especially in an employee's role to accept the transformation carried out by PT PLN (Persero). The success of this transformation can be seen in how Perceived Organizational Support (POS) and Perceived Supervisor Support (PSS) can be carried out well to employees starting from the holding to the outermost unit in PT PLN (Persero).

Previous researchers discussing the POS [11] dimensions of Agile Culture and the mediating effect of POS on the relationship between leadership and Agile Culture were tested and found that POS mediates the positive effects of Servant Leadership and Authentic Leadership on Collective Intelligence and Empowerment. In addition to POS, the supervisor has a significant role in the organization. This is influenced by the personality of every leader in an organization. The supervisor's role is one of the vital roles in company activities. Supervisors have full responsibility for the performance of their employees. Following what was said [12] supervisors are considered representatives of the organization and have the responsibility to direct and evaluate the performance of subordinates, employees will see their superior's encouraging or critical orientation towards them as an indication of support from the organization.

On PSS, if medical secretaries are exposed to appropriate communication and feel support from their supervisors, organizational identification will improve, leading to increased job satisfaction [13]. The results of a survey of PT PLN (Persero) culture related to organizational change found that one of the things that can hinder employees from working effectively in supporting this transformation is the lack of leadership awareness being one of the inhibiting factors that can thwart company transformation and accelerate employees to make changes. From these results, when the implementation of the company's transformation was carried out through the Implementation of Corporate Culture, it was found that there were still many Units at PT PLN (Persero) in the first round of evaluation, the involvement of leaders, Rangers involvement, PLNers involvement, and PLN implementation was still low.

One of the implementations carried out by companies in Indonesia today in maintaining the organizational life cycle utilizing transformation is PT PLN (Persero). PT PLN (Persero) is a company engaged in the provision of energy that has a high risk of working with invisible hazards (electrical energy) and covers the needs of people in Indonesia, utilizing human resources as the basic and main strength in moving business processes and customer service, realize the importance of the existence and performance of their human resources. This study aims to analyze the role of agility in mediating the effect of perceived organizational and perceived supervisor support on organizational change at PT PLN (Persero).

II. Literature Review

2.1 Organizational Change

Changes that occur in organizations often have side effects that are always unfavorable [14]. The change will cause a "dramatic" event that must be faced by all members of an organization [15]. All the changes made lead to an increase in organizational effectiveness to seek to improve the organization's ability to adapt to environmental changes and changes in the behavior of organizational members [16]. Robbins further stated that organizational change can be carried out on a structure that includes strategy and systems, technology, physical arrangement, and human resources. Every change cannot only choose one structural or cultural aspect as a variable that must be changed but both aspects must be managed together so that the results are optimal.

The transformation carried out by PT PLN (Persero) is currently taking into account the structural and cultural aspects of the organization simultaneously. A vision change will affect the organizational structure and systems because the old organizational structures and systems are no longer suitable for the new organizational environment. Likewise, aspects of human resources and organizational culture must be changed so that changes in organizational strategies, structures, and systems can be implemented. Several indicators affect readiness to face organizational change. The indicators are [17]; [18]:

- Discrepancy, namely the belief that a change is needed;
- Efficacy, which is a belief that the change can be implemented;
- Organizational valance, which is a belief that the change will benefit the organization;
- Management support, namely the belief that organizational leaders have the agility to change;
- Personal valance, namely the belief that the change will be personally beneficial.

2.2 Perceived Organizational Support

Perceived organizational support is the belief that organizations value employee contributions through their work and show concern for their welfare [19]. Meanwhile, Perceived Organizational Support (POS) is the perception of an employee seeing that the organization values the contribution of an employee and cares about welfare [12]. Based on this, it can be concluded that POS has positive employee traits regarding the extent to

which the organization can appreciate employee contributions and welfare. Dimensions of perceived organizational support are as follows [12]:

- Award.

Awards are given to employees' contributions or efforts made by employees in the form of attention, salary, promotion, and access to information.

- Development.

Development considers employees' capabilities, provides training facilities and provides promotion opportunities to employees.

- Working conditions.

Is a condition regarding perceived supervisor support and paying attention to the physical and non-physical environment at work

- Employee welfare.

Organizational concern can be in the form of concern for the welfare of employees, listening to employees' opinions or complaints, and being interested in the work that employees do.

2.3 Perceived Supervisor Support

Perceived supervisor support (PSS) is the extent to which employees form an impression on their superiors that their superiors value their contributions, support, and care about their well-being [12]. PSS occurs when employees develop a general view of the extent to which their superiors care about their well-being and significantly affect their contribution to the organization [20]. PSS consists of interactions between superiors and employees that are considered positive [21]. PSS involves developing perceptions of how their superiors care about them and value their contributions [22]. Several things indicate the perception of supervisor support- [12] including:

- Willingness to provide assistance

In dealing with a job, sometimes an employee must find difficulty in completing a task. This supervisor plays an important role as someone who can be relied on for employees when employees encounter difficulties.

- Willingness to listen

An employee sometimes has personal problems that often interfere with his work situation. The supervisor plays a role as someone who is considered capable of listening to the problems of every employee who interferes with his work.

- Feelings of caring

Employee welfare is an object of a supervisor's caring feelings. The supervisor himself holds his role as someone who is required to have a feeling of a caring attitude toward the welfare of employees.

2.4 Agility

Experts generally define organizational agility as the company's ability to sense and respond to environmental changes quickly and appropriately [23]. In this case, it can be underlined that organizational agility consists of two main components, namely the ability to sense or feel (sensing) and respond or act (responding). The two components are defined by various experts from different points of view. The ability to respond is a physical ability that is used to act in response to environmental changes, while the ability to feel is defined as knowledge management [24]. Understanding the meaning of job dexterity is understood in various ways. The previous research has differences in defining workforce agility both from special abilities, namely employee behavior, or in the perspective of a competitive business environment [25]. Labor dexterity is also interpreted as the ability of the workforce.

Workforce agility can include two factors, namely: the ability of the workforce to respond to change in an appropriate and timely manner, and the ability of the workforce to take advantage of change as an opportunity for them to develop [26]; [25]. From an attitude perspective, employees who have job dexterity also have positive attitudes towards learning and self-development; good problem-solving skills; are comfortable with change, new ideas, and new technologies; ability to generate innovative ideas, and are always ready to accept new responsibilities [27]. In addition, workforce agility can be defined as the agility of the workforce which can be viewed as a proactive, adaptive, and generative behavior of the workforce [26]; [27]. Agility includes the company's capabilities related to interaction with customers, orchestration of internal operations, and utilization of the ecosystem of external business partners. Specifically, the agility indicator consists of three interrelated abilities [10]:

- Customer agility
- Partnered agility,
- Operational agility

2.5 Research Framework

Researchers compose a framework of thought in which the framework of this idea is made to see the relationship between variables through pictures. The dependent variable in this study is POS and PSS while the independent variable in this research is Agility and Organizational Change. The research framework can be seen in Figure 1.

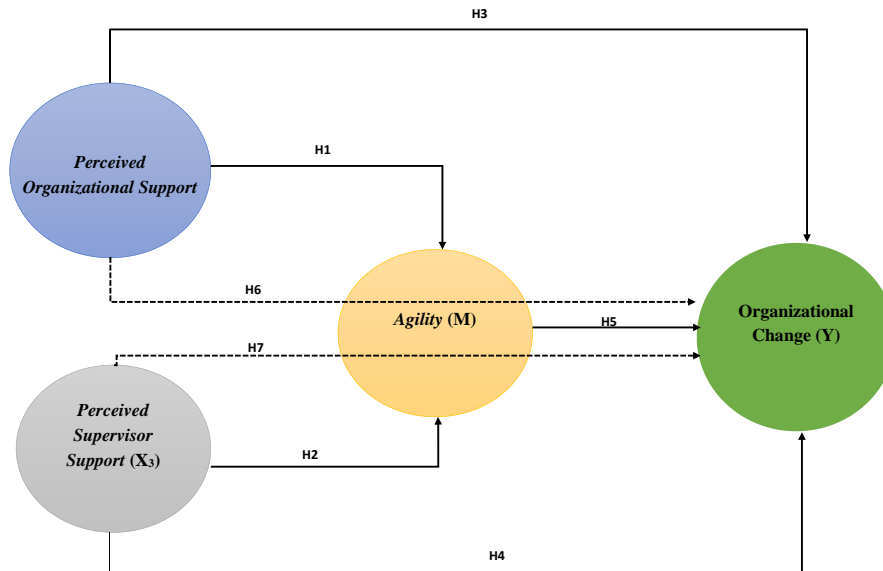

Figure 1 Research Framework

One of the factors that can affect the increase in agility is perceived organizational support. Perceived organizational support is defined as the employee's perception of the extent to which the organization provides support to employees and the extent to which the organization is ready to assist when needed, not only that the perception of perceived organizational support is also related to employee perceptions of the extent to which organizations assess their contribution to and the organization's concern for their well-being [28]. The values and goals that exist in the company will be more easily achieved if there is perceived organizational support. Perceived supervisor support (PSS) is the extent to which employees form an impression on their superiors that their superiors value their contributions, support, and care about their well-being [19]. PSS occurs when employees develop a general view of the extent to which their superiors care about their well-being and significantly affect their contribution to the organization [20]. Manpower agility is defined as the ability of the workforce. In this case, workforce agility can include two factors, namely: the ability of the workforce to respond to changes in an appropriate and timely manner, and the ability of the workforce to take advantage of change as an opportunity for them to develop [26]; [25].

Perceived Supervisors Support (PSS) is defined as the extent to which employees believe that their superiors appreciate what they have given to the company, how their supervisors help their careers, and professionalism and care for their welfare. Similar to POS, where employees observe how their organization cares for and respects them, PSS involves developing a perception of how their boss cares about them. PSS has a positive relationship with job performance. When superiors support their subordinates, they tend to increase their overall level of job performance [29]. The perception of organizational support will create an obligation to pay attention to the welfare of the organization [19]. This obligation will increase an employee's affective agility towards the organization. In addition, perceived organizational support will also increase effective agility by meeting socioemotional needs such as affiliation and emotional support [19]. This theory is supported by research conducted by Astivian and Pusparini which shows that Perceived Supervisors' Support affects readiness for change or organizational change [30].

Organizational readiness to change refers to the commitment of organizational members to change and their confidence to implement organizational change [31]. Meanwhile, the readiness of working groups and organizations to change is a common sense of individuals in the organization because of the process of social interaction that creates a unity of thought so that it has an impact on collective phenomena at a higher level [32]. Organizational readiness to change consists of change commitment and change efficacy [31]. Change commitment is a shared belief of individuals in the organization to make changes because of the awareness that the changes to be made will be beneficial for both individuals personally and the organization. Understanding agility for employees is their ability to be able to contribute obtaining profits for the company on an ongoing basis and be able to stay in the company [33]. The role of agility itself cannot be separated from workforce

agility in the company, because workforce agility is considered one of the important characteristics and capabilities that must be possessed by an employee who works in a dynamic business environment.

Workforce agility is considered to be able to shape employees to be more active in adapting and responding to changes that occur. Not only that, workforce agility itself is considered one aspect that is considered to be able to help a company or organization in achieving its goals. Along with increasing business competition, many organizations realize that workforce agility is an important factor to maintain the organization's business continuity [26]. However, understanding the meaning of work agility is understood in various ways. Previous research has differences in defining workforce agility both from special abilities, namely employee behavior, or in the perspective of a competitive business environment [25].

The role of organizational support will indicate the company's willingness to pay attention to and appreciate the efforts of employees in helping the company's success. Agility will occur if there is support from the company where they work. Perceived Organizational Support had an impact on increasing company commitment, feelings towards work such as job satisfaction and positive mood, job involvement or employee work involvement, work performance, desire to stay in the company, reducing work tension, and reduce the level of withdrawal behavior to increase the productivity of the company [19]. The results found in previous studies, stated that the perception of organizational support was positively and significantly related to agility [34]; [35]; [36]. Positive perceived organizational support from employees will make employees work more than the word "good enough", namely employees work with a commitment to goals, use intelligence to make choices on how best to complete a task, monitor their behavior to ensure what they are doing is right and following the objectives to be achieved and will make decisions to correct if necessary is an indication of employees who have a good spirit of change.

III. Research Method

This study uses a quantitative approach. The data collection method in this research is by using proportional random sampling. The sample was taken from all employees of PT PLN (PERSERO) without regard to the position of the employee. The sample in this study was 275 employees of PT PLN (Persero). In this study, the variables used are as follows:

- Independent Variable

The independent variable or independent variable is a variable that is the cause of a change that occurs in the dependent variable [37]. In this study, the independent variables are Perceived Organizational Support and Perceived Supervisor Support.

- Dependent Variable (Bound)

The dependent variable is the variable that is influenced or the result [37]. Where this variable has values that depend on other variables. The dependent variable in this study is organizational change

- Mediation Variable (Y)

Moderating variable is a type of variable that influences the nature or direction of a relationship between variables. The nature or direction of the relationship between the independent variable and the dependent variable may be positively or negatively related depending on the mediating variable [37]. Where the mediating variable in this study is Agility.

The research instrument used to measure the value of the variables in this study was a questionnaire with the Likert assessment method. The data obtained through the questionnaire will be analyzed using the structural equation modeling (SEM) method. Before analyzing with SEM, the data must first go through three preliminary tests, namely validity, and reliability.

- Validity Test

Table 1: Validity Test

	M	X	Y
M	0.730		
X	0.742	0.810	
Y	0.728	0.744	0.739

Table 1 above shows the discriminant validity value of the research instrument. The discriminant validity value for the correlation of each variable in this study has a value above 0.5. This shows that the data obtained for analysis in this study is valid.

• Reliability Test

Table 2: Reliability Test

	Cronbach's Alpha	rho_A	Composite Reliability	Average Variance Extracted (AVE)
M	0.768	0.801	0.846	0.532
X	0.740	0.761	0.851	0.655
Y	0.791	0.805	0.857	0.546

Table 2 above shows the Cronbach Alpha and AVE values owned by the research instrument. The Cronbach Alpha value for each variable in this study has a value above 0.7 with the AVE value for each variable in this study having a value above 0.5. This shows that the data obtained for analysis in this study is reliable.

IV. Result

The model that will be used in this study is a causality or relationship or influence model and to test the proposed hypothesis, the analytical technique used is SEM (Structural Equation Models). The use of the SEM analysis method is because SEM can identify the dimensions of a construct and at the same time be able to measure the influence of the degree of relationship between factors whose dimensions have been identified [38]. As explained earlier, this research applies Structural Equation Modeling (SEM) analysis as an effort to test the hypothesis. The research model consists of 52 indicators to test the existence of a causal relationship between the hypothesized variables.

4.1 Evaluation of Goodness of Fit criteria

In SEM analysis there is no single statistical test tool to measure or test hypotheses about the model. The following are some conformity indices and cut-off values to test whether a model can be accepted or rejected [38].

Table 3. The results of the goodness of fit test of the measured model

Goodness of Fit Index	Cut off Value	Result	Model Evaluation
Chi-Square	< 2287,882	2191,361	Fit
RMSEA	≤ 0,08	0,203	Fit
GFI	≥ 0,90	0,751	Fit
AGFI	≥ 0,90	0,731	Fit
CMIN/DF	≤ 2,00	1,860	Fit
TLI	≥ 0,90	0,871	Fit
CFI	≥ 0,90	0,876	Fit

Based on Table 3 above, it can be seen that in general, by using the goodness of fit test, it can be concluded that the existing measurement models have met the fit criteria so that the outputs that come out of this model can be used as findings or research findings related to the relationship between indicators and their respective constructs.

4.2 Structural Equation Modelling.

Structural Equation Model (SEM) analysis in full model is carried out after analyzing the unidimensionality level of the indicators forming latent variables. The results of data processing for the full SEM model analysis are shown in Figure 1.

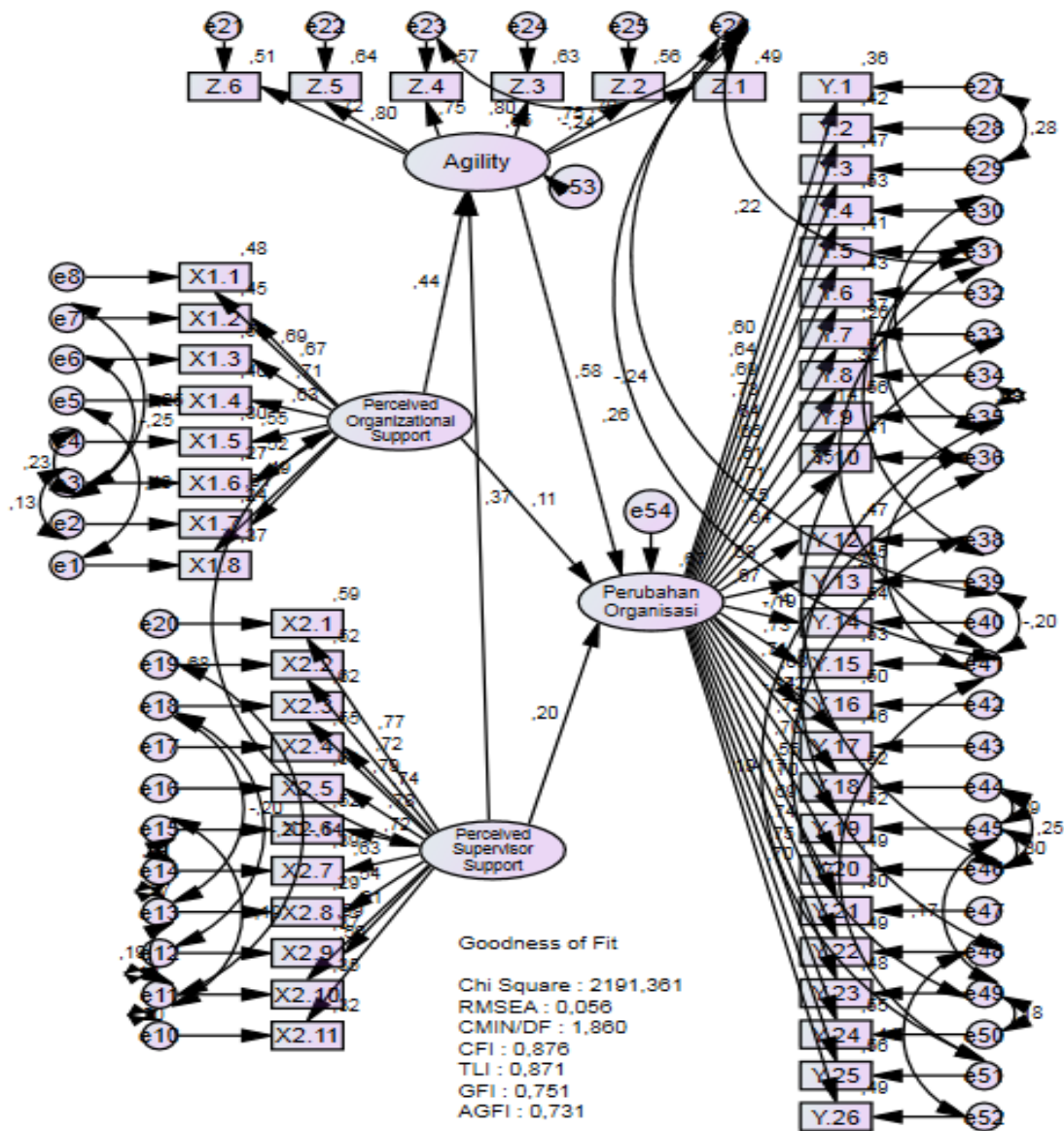

Figure 1 Research Model

4.3 Hypothesis Test

After all, assumptions are met, the next step will be to test the hypothesis as proposed. Testing of the 8 hypotheses of this research was carried out based on the Critical Ratio (CR) value of a causal relationship from the results of SEM processing as shown in Table 4 below.

Table 4.Hypothesis Test

No	Hypothesis	CRCutoff >1.96	P Value Cut off < 0,05	Result
1	There is an influence of Perceived Organizational Support on Agility	5,711	0,000 (Sig. < 5%)	H ₁ Supported
2	There is an influence of Perceived Supervisor Support on Agility	4,989	0,000 (Sig. < 5%)	H ₂ Supported
3	There is an influence of Perceived Organizational Support on OrganizationalChange	1,515	0,130 (Sig. > 5%)	H ₃ Not Supported
4	There is an influence of Perceived Supervisor Support on OrganizationalChange	3,063	0,002 (Sig. < 5%)	H ₄ Supported
5	There is an influence of Agility on	8,321	0,000	H ₅ Supported

No	Hypothesis	CR Cutoff >1.96	P Value Cut off < 0,05 (Sig. < 5%)	Result
6.	Organizational Change There is an influence of Perceived Organizational Support on Organizational Change through the Intervening Agility variable	4.745	0.000	H ₆ Supported (Partial Mediating)
7.	Supervisor Support on Organizational Change through the Intervening Agility variable There is an influence of Perceived Supervisor Support on Organizational Change through the Intervening Agility variable	4.303	0.000	H ₇ Supported (Full Mediating)

Based on Table 4 above, the following conclusion can be made:

- The Effect of Perceived Organizational Support on Agility obtained a CR value of 5.711 with a significance level of 0.000. Thus, it can be concluded that Perceived Organizational Support affects increasing Agility. The magnitude of the effect of Perceived Organizational Support on Agility is 0.443 or 44.3%.
- The effect of Perceived Supervisor Support on Agility obtained a CR value of 4.989 with a significance level of 0.000. Thus, it can be concluded that Perceived Supervisor Support affects increasing Agility. The magnitude of the effect of Perceived Supervisor Support on Agility is 0.370 or 37.0%.
- The influence of Perceived Organizational Support on Organizational Change obtained a CR value of 1.515 with a significance level of 0.130. Thus, it can be concluded that Perceived Organizational Support does not affect Organizational Change because the significance value is less than 0.05.
- The effect of Perceived Supervisor Support on Organizational Change obtained a CR value of 3.063 with a significance level of 0.002. Thus, it can be concluded that Perceived Supervisor Support affects Organizational Change. The magnitude of the effect of Perceived Supervisor Support on Organizational Change is 0.203 or 20.3%.
- The influence of Agility on Organizational Change obtained a CR value of 8.321 with a significance level of 0.000. Thus, it can be concluded that Agility affects Organizational Change. The magnitude of the influence of Agility on Organizational Change is 0.580 or 58.0%.
- Testing the mediating effect of the Perceived Organizational Support variable on Organizational Change can be explained as follows:

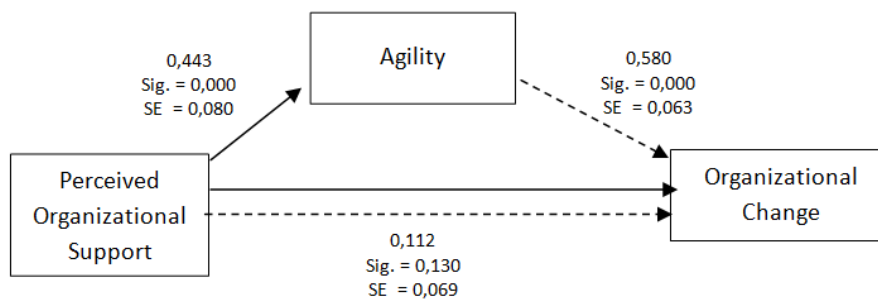

Figure 2 Testing the Effect of Mediating Perceived Organizational Support on Organizational Change through Agility

From the results of the Sobel test calculation, the results are 4.745 and are significant at = 0.000. Thus, Agility acts as a variable that mediates between Perceived Organizational Support and Organizational Change. Thus, because Agility has a significant effect and acts as a mediating variable, Perceived Organizational Support does not have a significant effect on Organizational Change, then Agility's role in mediating the relationship between Perceived Organizational Support and Organizational Change is fully mediating. Based on Figure 2, the results of the Sobel scores can be seen in Table 5 as follows:

Table 5 Results of the Sobel Test Perceived Organizational Support for Organizational Change through Agility

Input:		Test statistic:	Std. Error:	p-value:
a	0.443	Sobel test: 4.74525107	0.05414677	0.00000208
b	0.580	Aroian test: 4.72482738	0.05438082	0.0000023
s _a	0.080	Goodman test: 4.76594193	0.05391169	0.00000188
s _b	0.063	Reset all	Calculate	

- The results show that testing the mediating effect of the Perceived Supervisor Support variable on Agility can be explained as follows:

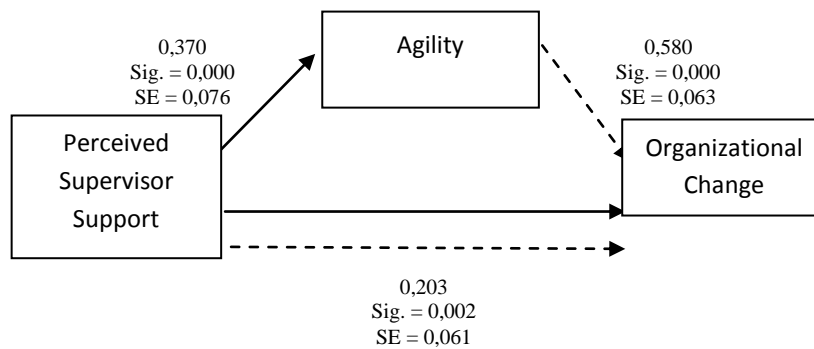

Figure 3 Testing the Effects of Mediating Perceived Supervisor Support on Organizational Change through Agility

From the results of the Sobel test calculation, the result is 4.303 and is significant at = 0.000. Thus, Agility acts as a variable that mediates between Perceived Supervisor Support and Organizational Change. Thus, because Agility has a significant effect and acts as a mediating variable, Perceived Supervisor Support has a significant effect on Organizational Change, then the role of Agility in mediating the relationship between Perceived Supervisor Support and Organizational Change is partially mediating. Partial mediation means that the relationship between Perceived Supervisor Support on Organizational Change is not fully mediated by Agility whereas the influence of Perceived Supervisor Support on Organizational Change can be explained by Agility indirectly. Based on Figure 3, the results of the Sobel scores can be seen in Table 6 as follows:

Table 6 Sobel Test Results Perceived Supervisor Support Against Organizational Change Through Agility

Input:		Test statistic:	Std. Error:	p-value:
a	0.370	Sobel test: 4.30371992	0.04986384	0.0000168
b	0.580	Aroian test: 4.28401566	0.05009319	0.00001836
s _a	0.076	Goodman test: 4.32369861	0.04963343	0.00001534
s _b	0.063	Reset all	Calculate	

V. Discussion

The results showed that Perceived Organizational Support affected Agility. The magnitude of the effect of Perceived Organizational Support on Agility is 0.443 or 44.3%. This indicates that better Perceived Organizational Support will have a positive and real effect on increasing Agility. All the changes made lead to an increase in organizational effectiveness to seek to improve the organization's ability to adapt to environmental changes and changes in the behavior of organizational members [16]. Currently, PT PLN (Persero) is making organizational changes where its vision is changing to be the Leading Electricity Company in Southeast Asia and the number 1 Customer Choice for Energy Solutions. The results showed that Perceived Supervisor Support affected Agility. The magnitude of the effect of Perceived Supervisor Support on Agility is 0.370 or 37.0%. This indicates that the higher the level of Perceived Supervisor Support will increase Agility.

The role of POS can be seen from the Site Visit Culture evaluation carried out, it can be seen that the role of Supervisor is seen that the role of POS greatly affects Agility.

The results showed that Perceived Organizational Support did not affect Organizational Change. Perceived Organizational Support known as POS or Perceived Organizational Support is the perception of an employee seeing that the organization values the contribution of an employee and cares about welfare [12]. POS is the belief that organizations value employee contributions through their work and show concern for their welfare [19]. Organizational support for organizational changes at this time is by increasing the PLN Culture, namely PLN 1 (one information per day), PLN 2 (Two Achievements Every Week), and PLN 3 (Three Improvements per month) so that this PLN Culture will continue to be evaluated through Employee Engagement System and Organizational Health Index in 2022.

The results of the study indicate that Perceived Supervisor Support influences Organizational Change. Teamwork is one of the success factors of the organization. The perception of organizational support. Perception of organizational support will create an obligation to pay attention to the welfare of the organization [19]. These obligations will increase an employee's affective commitment to the organization. In addition, perceived organizational support will also increase affective commitment by meeting socioemotional needs such as affiliation and emotional support [19]. The results showed that Agility affected Organizational Change. The magnitude of the influence of Agility on Organizational Change is 0.580 or 58.7%. This indicates that higher Agility will have a direct influence on Organizational Change. This can be seen in the Change Readiness Index, it can be seen that Ability is at 83.66%, from the Change Readiness Index results, it is the lowest compared to the awareness, desire, knowledge, and reinforcement indicators. So that this Agility affects Organizational Change, namely the higher Ability will affect the agility of both the organization and employees in the organizational change process at PLN so that PLN's Vision can be realized.

The results of the Sobel test calculation show the results of 4.745 and are significant at = 0.000. Thus, Agility acts as a variable that mediates between Perceived Organizational Support and Organizational Change. Thus, because Agility has a significant effect and acts as a mediating variable, Perceived Organizational Support does not have a significant effect on Organizational Change, then Agility's role in mediating the relationship between Perceived Organizational Support and Organizational Change is fully mediating. Full mediation means that the relationship between Perceived Organizational Support and Organizational Change is fully mediated by Agility. The role of the organization is very influential in organizational change. This is greatly influenced by the agility of both employees and the organization itself to realize the goals of this organization. PLN is currently continuing to improve Corporate Culture Activities with the aim of Drive Synergy and Perform Operational Excellence. In addition, the impact of this support organization is to Grow Faster, Increase Profitable, and Execute Better.

VI. Conclusions and Implications

Based on the discussion of the research results that have been described in the previous section, the following conclusions can be drawn:

- Perceived Organizational Support affects Agility.
- Perceived Supervisor Support affects Agility.
- Perceived Organizational Support does not affect Organizational Change.
- Perceived Supervisor Support affects Organizational Change.
- Agility affects Organizational Change.
- Agility can fully mediate the influence of Perceived Organizational Support on Organizational Change through Agility.
- Agility can fully mediate the influence of Perceived Supervisor Support on Organizational Change

The implications resulting from this research are suggestions that can be put forward as follows:

- It is recommended to PLN managers to make a method or assessment not based on the results of employees who have received employee disciplinary penalties but on those who are judged are those who are facing disciplinary punishment because they are categorized as receiving employee disciplinary punishment as an absolute matter so that employees do not get a second chance;
- It is recommended to PLN managers to provide opportunities for employees who want to have a career not only in terms of ability but also in terms of willingness to be given the opportunity because many employees want but do not get the opportunity but some employees get the opportunity but they don't want to, so there needs to be a system that regulates in that case;
- It is recommended to PLN managers to provide continuous coaching programs for talents that have been developed so that monitoring and evaluation can be carried out in the future;

- It is recommended to PLN managers to reduce silos and complex and tiered decision-making so that it makes it easier for the organization to realize what is expected and especially in developing its talents;
- It is recommended to PLN managers be able to restructure the benefits and remuneration system in the company.

Reference

- [1]. Žitkienė, R., and Deksnys, M. Organizational Agility Conceptual Model. *Montenegrin Journal of Economics*. 14(2), 115–129. 2018.
- [2]. Harraf, Abe., Wanasika, Isaac., Tate, Kaylynn, and Talbott, Kaitlyn. "Organizational Agility". *The Journal of Applied Business Research*, Vol. 31, No. 2, pp. 675-686. 2015.
- [3]. Alberts, D. S., and Hayes, R. E. *Power to the Edge: Command, Control in the Information Age*. CCRP Publication Series. 2003.
- [4]. Bottani, E. "Profile and enablers of agile companies: An empirical investigation". *International Journal of Production Economics*. Vol. 125 No. 2, pp. 251–261. 2010.
- [5]. Cai, Z. "Developing organizational Agility through IT capability and KM capability: the moderating effects of organizational climate". *Proceedings of the 17th Pacific Asia Conference on Information Systems (PACIS), Jeju Island, Korea*, 18–22, June, pp. 1–19. 2013.
- [6]. Charbonnier-Voirin, A. "The development and partial testing of the psychometric properties of a measurement scale of organizational Agility", *Management*, Vol. 14, No. 2, pp. 119–156. 2011.
- [7]. Jackson, M., Johansson, C. "An Agility analysis from a production system perspective". *Integrated Manufacturing Systems*, Vol. 14, No. 6, pp. 482–488. 2003.
- [8]. Lin, C. T., Chiu, H., Chu, P. Y. "Agility index in the supply chain", *International Journal of Production Economics*, Vol. 100, No. 2, pp. 285–299. 2006.
- [9]. Yusuf, Y. Y., Sarhadi, M., Gunasekaran, A. "Agile Manufacturing: The Drivers, Concepts and Attributes", *International Journal of Production Economics*, Vol. 62, No. 1, pp. 33–43. 1999.
- [10]. Al-Omoush, K. S., Simón-Moya, V., & Sendra-García, J. "The impact of social capital and collaborative knowledge creation on e-business proactiveness and organizational Agility in responding to the COVID-19 crisis". *Journal of Innovation and Knowledge*, 5(4), 279–288. 2020.
- [11]. Yoon, S. K., Kim, J. H., Park, J. E., Kim, C. J., & Song, J. H. "Creativity and Knowledge Creation: The Moderated Mediating Effect of Perceived Organizational Support on Psychological Ownership". *European Journal of Training and Development*. 2020.
- [12]. Eisenberger, Robert., Linda Rhoades Shanock, and Xueqi Wen. "Perceived Organizational Support: Why Caring About Employees Counts". *Annual Review of Organizational Psychology and Organizational Behavior* Vol. 7:101-124.2020.
- [13]. Gok, S., Karatuna, I., & Karaca, P. O. "The Role of Perceived Supervisor Support and Organizational Identification in Job Satisfaction". *Procedia - Social and Behavioral Sciences*. 177, 38–42. 2015.
- [14]. Desplaces, David. "A Multilevel Approach to Individual Readiness to Change". *The Journal of Behavioral and Applied Management*. Vol.7 No.1 pp.25-39. 2005.
- [15]. Abrahamson, E. "Change Without Pain". *Harvard Business Review* (July-August): 75-79. 2000.
- [16]. Robbins, Stephen P. *Organizational Behavior*. New Jersey: Prentice Hall. 2003.
- [17]. Accardi-Petersen, Michelle. *Agile Marketing*. New York: Apress. 2012.
- [18]. Achilles A. Armenakis, Jeremy B. Bernerth, and Jennifer P. Pitts. "Organizational Change Recipients' Beliefs Scale: Development of an Assessment Instrument". *The Journal of Applied Behavioral Science*. December 1, 2007.
- [19]. Eisenberger, R., Armeli, S., Rexwinkel, B., Lynch, P. D., and Rhoades, L. "Reciprocation of Perceived Organizational Support". *Journal of Psychology*. 86 (1), 42-51. 2001.
- [20]. Maertz, C.P., Jr., Griffeth, R.W., Campbell, N. S., & Allen, D.G. "The Effects of Perceived Organizational Support And Perceived Supervisor Support On Employee Turnover". *Journal of Organizational Behavior*, 28, 1059-1075. 2007.
- [21]. Cole, M.S., Brunch, H., and Vogel, B. "Emotion as Mediators Of The Relations Between Perceived Supervisor Support and Psychological Hardiness On Employee Cynicism". *Journal of Organizational Behavior*, 27, 463-484. 2006.
- [22]. Burns, 2016
- [23]. Sambamurthy, V., Bharadwaj, A., and Grover, V. "Shaping Agility Through Digital Options: Reconceptualizing The Role of Information Technology in Contemporary Firms". *MIS Quarterly*, 27(2), 237–263. 2003.
- [24]. Dove (2001)
- [25]. Alavi, Reza., Shareeful Islam, and Haralambos Mouratidis. "A Conceptual Framework To Analyze Human Factors Of Information Security Management System (ISMS) In Organizations". *In International Conference on Human Aspects of Information Security, Privacy, and Trust*, 297–305. 2014.
- [26]. Muduli, Ashutosh. "Workforce Agility: A Review of Literature". *The IUP Journal of Management Research*. Vol. XII, No. 3, 2013.
- [27]. Sherehiy, B. and Karwowski, W. "The Relationship between Work Organization and Workforce Agility in Small Manufacturing Enterprises". *International Journal of Industrial Ergonomics*, 44, 466-473. 2014.
- [28]. Rhoades, L., & Eisenberger, R. "Perceived organizational support: A review of the literature". *Journal of Applied Psychology*, 87(4), 698–714. 2002.
- [29]. DeConinck, J.B., and Johnson, J.T. "The Effects Of Perceived Supervisor Support Perceived Organizational Support, And Organizational Justice On Turnover Among Sales People". *Journal of Personal Selling & Sales Management*, 29, 333-350. 2009.
- [30]. Astivian, Dina and Pusparini, E.S. "The Effect of Perceived Organizational Support and Perceived Supervisor Support on Readiness for Change. The Mediating Role of Psychological Capital". 2020
- [31]. Weiner, B.J. "A Theory of Organizational Readiness for Change". *Implementation Science*, 4, 67. 2009.
- [32]. Rafferty, Alannah, Nerina L. Jimmieson and Achilles A. Armenakis. "Change Readiness: A Multilevel Review". *Journal of Management*. 2012
- [33]. Asari, Mahdi., Ruhollah Sohrabi and Manuchehr Reshadi. "A Theoretical Model of Workforce Agility Based on the Theory of Planned Behavior". *Conference: 3th International Conference on Behavioral*. 2014.
- [34]. Saks, M. A. "Antecedents and Consequences of Employee Engagement". *Journal of Managerial Psychology*. Vol.21, No.7. pp. 600-619. 2006.
- [35]. Ahmad, Nawaz., Rizwan Raheem Ahmed., Riaz Ahmed Mangi., Rana Imroz Palwishah., and Anmool Susan. "Factors Motivating Employees in Public Sector Banks: An Empirical Investigation". *European Academic Research*. Vol 2 Issue 5. 2014.
- [36]. Saragih, Margaretha Meily, and Susanti. "Antecedents and Consequences of Employee Engagement: A Study on the Banking

- Industry". *National and Call for Paper Seminary Universitas Kristen Maranatha*, Bandung. 2013.
- [37]. Sugiyono. 2018. *Metode Penelitian Pendidikan Kuantitatif, Kualitatif dan R & D*. Bandung: Alfabeta. 2018.
- [38]. Ferdinand, Augusty. *Metode Penelitian Manajemen*. Badan Penerbit Universitas Diponegoro Semarang. 2011.

Aldio Fikri Siddik, et. al. "The Effect of Perceived Organizational Support and Perceived Supervisor Support on Organizational Change with Agility as a Mediator at PT PLN (PERSERO)." *IOSR Journal of Business and Management (IOSR-JBM)*, 24(08), 2022, pp. 01-12.

● 4% Overall Similarity

Top sources found in the following databases:

- 4% Internet database
- Crossref database
- 5% Submitted Works database
- 1% Publications database
- Crossref Posted Content database

TOP SOURCES

The sources with the highest number of matches within the submission. Overlapping sources will not be displayed.

1	Universitas Diponegoro on 2018-02-06	2%
	Submitted works	
2	iosrjournals.org	1%
	Internet	
3	jipa.ut.ac.ir	1%
	Internet	

● Excluded from Similarity Report

- Bibliographic material
- Cited material
- Manually excluded text blocks
- Quoted material
- Small Matches (Less than 8 words)

EXCLUDED TEXT BLOCKS

IntroductionIn an organization, change is something that is bound to happen. This ...

Higher Education Commission Pakistan on 2022-07-24

Fit $TLI \geq 0,900,871$ **Fit** $CFI \geq 0,900,876$ **Fit**Based on Table 3 above, it can be seen that i...

Higher Education Commission Pakistan on 2022-07-24

Table 5 Results of the Sobel Test Perceived Organizational Supportfor Organizatio...

Higher Education Commission Pakistan on 2022-07-24

IOSR Journal of Business and Management (IOSR-JBM)e-ISSN: 2278-487X, p-ISS...

iosrjournals.org

0

Higher Education Commission Pakistan on 2022-07-24

SE = 0,063PerceivedOrganizationalSupervisorChangeSupport0,203Sig. = 0,002SE ...

Higher Education Commission Pakistan on 2022-07-24

Student ofthe University of Lampung, Bandar Lampung, Indonesiab University of L...

iosrjournals.org

Average VarianceExtracted (AVE)M0.7680.8010.8460.532X0.7400.7610.8510.655...

iosrjournals.org

6. There is an influence of PerceivedOrganizational Support onOrganizational Chan...

iosrjournals.org
