

PAPER • OPEN ACCESS

Damping Harmonic Oscillator (DHO) for learning media in the topic damping harmonic motion

To cite this article: I Festiana *et al* 2019 *J. Phys.: Conf. Ser.* **1157** 032062

View the [article online](#) for updates and enhancements.

You may also like

- [Weak pseudo-bosons](#)
F Bagarello
- [Demonstration of the universality of molecular structures in prolate deformed nuclei](#)
R Canavan and M Freer
- [On the absence of a positive sound dispersion in the THz dynamics of glycerol: an inelastic x-ray scattering study](#)
Alessandro Cunsolo



ECS The Electrochemical Society
Advancing solid state & electrochemical science & technology

242nd ECS Meeting

Oct 9 – 13, 2022 • Atlanta, GA, US

Early hotel & registration pricing ends September 12

Presenting more than 2,400 technical abstracts in 50 symposia

The meeting for industry & researchers in

BATTERIES
ENERGY TECHNOLOGY
SENSORS AND MORE!

 Register now!

  **ECS Plenary Lecture featuring M. Stanley Whittingham,**
Binghamton University
Nobel Laureate –
2019 Nobel Prize in Chemistry



Damping Harmonic Oscillator (DHO) for learning media in the topic damping harmonic motion

I Festiana^{1,2*}, K Herlina³, L S Kurniasari⁴ and S S Haryanti³

¹Program Studi Pendidikan Ilmu Pengetahuan Alam, Sekolah Pascasarjana Universitas Pendidikan Indonesia, Jl. Dr. Setiabudi No. 229, Bandung 40154, Indonesia

²Universitas Nahdlatul Ulama Lampung, Jl. Hanafiah Lintas Timur, Mataram Marga, Kabupaten Lampung Timur 34394, Indonesia

³Program Studi Pendidikan Fisika, Universitas Lampung, Jl. Sumantri Brojonegoro No. 1, Gedung Meneng, Rajabasa, Kota Bandar Lampung 35145, Indonesia

⁴SMA Negeri 1 Kalianda, Jl. Kol. Makmun Rasyid No 149, Kalianda, Kabupaten Lampung Selatan 35513, Indonesia

*ikefestiana@student.upi.edu

Abstract. This study aims to 1) design and create a damped harmonic oscillator as a learning media for damped harmonic oscillation, 2) to know the effect of the displacement on the number of waves formed and the wave period until the oscillation is stopped. The method used in this research is Design and Development Research (DDR). The specific phase of development consists of analysis, design, development, and evaluation. This research was conducted at one of the universities in Lampung. The subjects were 57 physics education students who taught the wave course. The damped harmonic oscillator consists of two systems: the first system consists of a paper drive system and the second system consists of pendulum and spring. The research results are: 1) DHO was made as a learning media on the topic of oscillation. 2) the value of displacement given affected the amplitude and wavelength as well as its period, but only slightly affected the damping coefficient 3) based on the results of usability test given to 57 students it showed that DHO is "good" to be used for teaching the subject of damped harmonic oscillations.

1. Introduction

In our life there are many examples of oscillation. Some examples of oscillation are the vibrating strings of the picked guitar, the vibrating vocal cords while people are speaking, the pendulum of the clock swinging from right to left, and the bungee jumping game also applies the oscillation principle [1]. Oscillations can occur when the system is disturbed from its stable equilibrium position, and the characteristic of the famous oscillation is the periodic motion, i.e. repetitive [2]. Vibration is the back and forth motion (oscillation) of a system that can be a continuous, regular, and repetitive or it can also be an irregular or random [3]. The motion consists of simple harmonic motion and damped harmonic motion. Simple harmonic motion and damped harmonic motion are fundamental topics of physics and are also very useful in engineering [4].

The requirement of a simple harmonic motion is when the acceleration of the object is directly proportional and its direction is opposite to its displacement [2]. A simple harmonic oscillator example is the motion of a mass object bound to a spring [5]. Study about a spring–mass system as one of the



most important examples of simple harmonic motion [6]. However, the spring or pendulum that oscillates over time will stop oscillating (damped). When the mechanical energy of the oscillation motion decreases with time, the object will stop moving and is said to be damped.

In a spring or pendulum system, one of harmonic vibration quantity obtained is period. Period (T) is the time needed by an object to perform one vibration (a vibration is when the object moves from the point where it starts to move and returns to that point) while frequency is the number of vibrations made by an object in one second. In addition to period and frequency, there is also amplitude. Amplitude is the maximum displacement from the equilibrium point.

There has been very little research on damped harmonic motion [4,7,8], therefore, a tool is needed to simulate this subject. The tool to be developed is called damping harmonic oscillation (DHO). DHO was designed and developed with the aims: 1) to describe the graph of the damped harmonic motion so as to see the energy lost in the motion. 2) to know the effect of the displacement on the number of waves formed and the wave period.

2. Method

This research used Design and Development Research (DDR) method [9]. DDR has two types, namely: type one is product and tool research and type two is the development of learning models. The specific phase of product development consists of analysis, design, development, and evaluation (see figure 1).

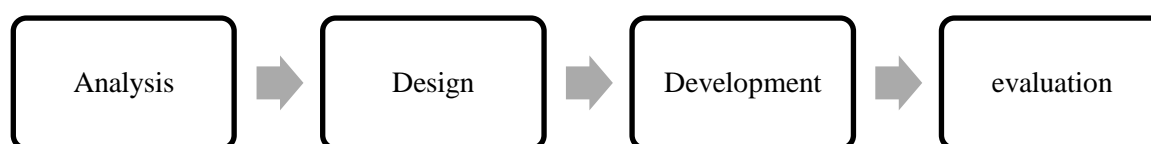

Figure 1. Specific project phases Design and Development Research (DDR).

In the analysis phase, we analyzed the need of teaching aids to teach the topic of physics on the subject course of wave. The result of the analysis showed that the teaching aids for damped harmonic motion were very few. Therefore teaching aids for the topic of damped harmonic motion were needed. The damped harmonic motion teaching aid we developed is called damping harmonic oscillation (DHO). DHO is here to assist students in understanding the subject of damped harmonic oscillations. Design stage is done by designing DHO and listing the tools used in the process of its making. Development stage is the process of making DHO. The evaluation stage is performed to find out the usability aspects of DHO.

3. Result and discussion

3.1. Design of DHO

DHO consists of two systems. The first system consists of a paper drive system and the second system consists of a pendulum and spring. Tools and materials required in the manufacture of DHO are wood, paper, nuts and bolts in various types, iron rod as paper rollers, nails, glue, 0.2 mm kraft paper, hacksaw, drilling machine, AC cord, switch, slow motor 33 rpm, iron plate, marker, spring, rail, wheel, PCB board, PVC pipe, iron rods with different diameter, weight from scrap metal. The first step in the process of making the tool is to make the sketch of the tool (see figure 2).

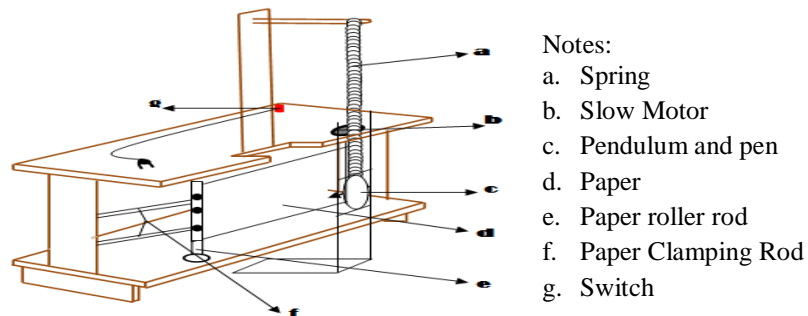

Figure 2. Design of DHO.

The second step is to prepare 2 pieces of paper rolling rods to a lathe workshop with a length of 30 cm and a diameter of 1.5 cm. The third step is to make the load using the wood and scrap metal and the pen slot retained with the iron plate and put the wheels at the right and left end (all these components are called loads and try to have 250 grams of mass) (see figure 3). The fourth step is to create a load rail using a curtain rail with a length of 50 cm and width of 14.5 cm (see figure 4). The fifth step is to create a paper support using a PCB board with a wheel (the wheels are fitted with a small bolt) (see figure 5) and connected with a thin steel iron made from a hacksaw.



Figure 3. Pendulum.



Figure 4. Rail.



Figure 5. Stopped paper.

Step six is to install the slow motor above the paper roller on the right then connect it using the switch along with the AC cord to connect to the electricity. The seventh step is to install the paper roll on the paper roller then to connect it to the axle connected to the slow motor. After that put a paper support made of a PCB board that has been wheeled. Assemble all the parts as in Figure 6.



Figure 6. Damped Harmonic Oscillator (DHO).

3.2. Experiment results

From observation, the following data were obtained on Table 1 and the results of OHT can be seen in the figure 7 with displacement 5 cm and Figure 8 with displacement 10 cm.

Table 1. Experiment with Displacement

Displacement	Experiment	Time (s)	Wave Length (cm)
5 cm	1	3.95	9.8
5 cm	2	3.90	10.2
5 cm	3	3.61	10.6
10 cm	1	6.63	17.5
10 cm	2	5.94	17.5
10 cm	3	5.85	18.5

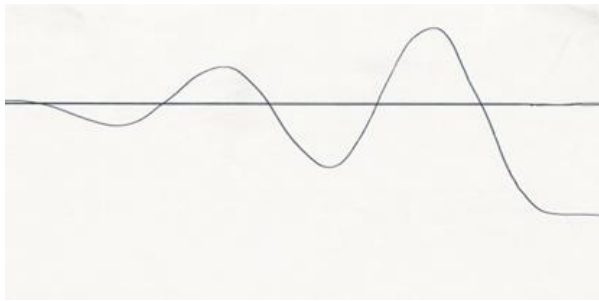

Figure 7. Experiment with displacement 5 cm.

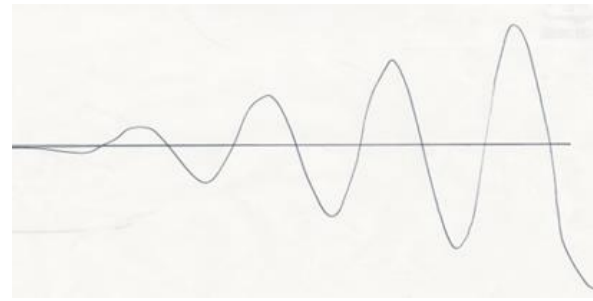

Figure 8. Experiment with displacement 10 cm.

Harmonic oscillation is the movement of an object that produces waves. To prove the existence of waves formed on the sprouted spring we made one tool called damping harmonic oscillator (DHO). This tool consists of two systems, the first system is a place for paper rolling and the second system is for spring drive.

The first system is a paper roller, where the paper will move rolling at a constant speed using a slow motor. The power needed for the slow motor is AC. Inside the slow motor there are small and big gears which are interconnected. Small gears have 10 teeth while big gears have 150 teeth. This is due to the ratio between small gears and big gears is 1:15. Initial rotation generated by the slow motor is 1,485 revolutions per minute. Since small gears and big gears are interconnected, the small gear will rotate the big gears when electric current flows. The big gear will rotate another big gear so that the resulting output rotation is 33 revolutions per minute.

It is the above rotation that we use to rotate the paper in system 1. The rotation of the slow motor is considered sufficient to rotate the paper constantly and well since the approximate swing of the pendulum in system 2 is about 20 revolutions per minute. With such ratio it is expected that the wave resulted can be well formed.

In order to roll the paper, slow motor is connected with lathed iron rod that serves as the base where the paper rolls. There are two lathed iron rods, the first lathed iron rod connected to the slow motor, while the second iron rod follows rotation of the first rod. Like the movement on a motorcycle, the front wheels follow the rear wheel motion. The slow motor is also connected to the switch that can control the current in the slow motor. As the slow motor uses AC then slow motor can move back and forth. What is desired is the paper rotates to the right, so when the slow motor moves towards the left, slow motor is turned off, then turned on again until it moves towards the right. The moving or rolling paper to the right is the base where the tip of the marker shows the waves formed later when all the systems work.

The second system is where the spring moves, for the wave to be visible. The moving spring is hung on an iron mounted horizontally and attached to the retaining timber attached to the first system. At the

spring a load is added with a mass of 250 grams which consists of a load made of steel piece attached to a round wood, and a marker that is fixed with a holder, this marker will draw the wave form. In order that the spring does not move in any direction, a rail is provided which is made of the rail commonly used on the curtain. On the wood load is given a small iron with a wheel end. The wheels are on the rail track. The use of this rail is to minimize friction and to remain constant or not moving away.

After all the system is well-arranged and interconnected, the data is taken with the control variable of the displacement provided. Repeated three times, the data are recorded for each displacement. This repetition is done so that the data obtained is valid.

The data obtained are as follows: with 5 cm displacement, first data was obtained. The system generated two waves with a wavelength of 9.8 cm in 3.95 seconds. In the second experiment with the same displacement, two waves of 10.2 cm in 3.9 seconds were obtained, and in the third experiment it generated two waves of 10.5 cm wavelength in 3.61 seconds.

In addition to using the 5 cm displacement we also used 10 cm displacement. By experimenting with the same steps above data are obtained as follows: the first experiment generated four waves with a wavelength of 17.5 cm in 6.63 seconds. The second experiment generated four waves with a wavelength of 18.1 cm in 5.94 seconds. The last experiment with the same displacement of 10 cm generated four waves with a wavelength of 18.5 cm in 5.85 seconds. All data were obtained when it started releasing the spring until the spring stopped swinging, and the pen no longer drew waves but straight lines, or in other words damping occurs.

As this experiment uses a spring, it is necessary to know the constant of the spring. The spring constant is found by experimenting i.e. by hanging a load with different mass variables, then calculate the displacement. The difference in the length of the spring before being loaded with a mass and the length of the spring after being loaded with the mass (Δx) is used in the next calculation. By using the principle of Hooke, $F = k \Delta x$, so $k = (m g) / \Delta x$ then the spring constant is known.

To determine the spring constant the experiment was repeated 4 times with mass 1 = 100 gram; mass 2 = 200 grams; mass 3 = 250 grams and mass 4 = 500 grams. After taking the data and calculating using Hooke's formula and assuming that the local gravitation acceleration is 9.8 m/s^2 then the average spring constant we used in the experiments is known to be 0.064 N/m .

The differences in time, and the number and length of waves formed in the experiment were caused by the lack of precision in turning on and off the stopwatch when experimenting.

Then we made calculation again to find out the damping coefficient (b) by using the formula $b = 2m\sqrt{(k / m - (2\pi / T)^2)}$. Before calculating the damping coefficient, first we had to find out the wave period because the wave period is used in the calculation of damping coefficient. The wave period is calculated by using the formula $T = t / n$. By using the formula we obtained $T_1 = 1.975$ second; $T_2 = 1.95$ seconds; $T_3 = 1.805$ seconds at 5 cm displacement. While at the displacement of 10 cm $T_1 = 1.65$ seconds; $T_2 = 1.48$ seconds; $T_3 = 1.46$ seconds. After the wave period is known then the damping coefficient can be calculated. Result of calculation hence obtained $b_1 = 1.56 \text{ i}$; $b_2 = 1.59 \text{ i}$; and $b_3 = 1.72 \text{ i}$ for spring with 5 cm displacement while for displacement 10 cm then we obtained $b_1 = 1.8 \text{ i}$; $b_2 = 2.1 \text{ i}$; and $b_3 = 2.3 \text{ i}$.

3.3. Usability test result

The usability aspect consists of four: usefulness, ease of use, ease for learning, and satisfaction. Usability is useful for giving recommendation of DHO tools and evaluates the interaction between user and the system [10]. The result of usability test given to the students can be seen in figure 9.

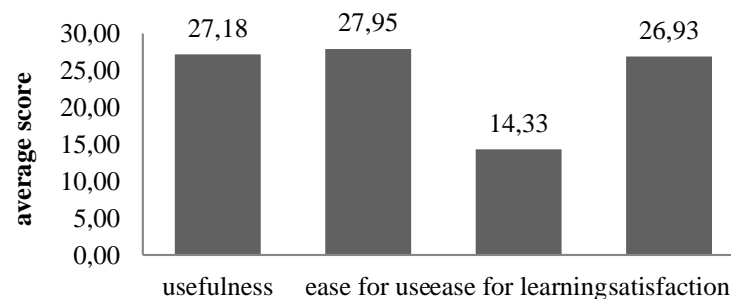

Figure 9. Usability Test Result of DHO.

Usability is necessary to be given to students so that DHO can be used as a teaching aid to explain the topic of damped harmonic motion. Questionnaires were given to 57 students using a scale of 1-5. Usability consists of usefulness aspect which has 7 questions, ease for use with 8 questions, ease for learning with 4 questions, and satisfaction with 7 items of questions. The questionnaire calculation takes into account the number of items, minimum and maximum score, median and standard deviation so that it can be categorized into very good, good, fair, or poor. Based on the results of the calculation of the four aspects of usability DHO fell into the “good” category so it can be concluded that the tool can be used properly as a teaching media in the topic of damped harmonic motion.

4. Conclusion

Based on the research, it can be concluded that DHO with usability test result "good" can be used to explain the subject of damped harmonic motion. The magnitude of the given displacement affects the amplitude and wavelength and its period but affects only slightly the damping coefficient.

Acknowledgments

Acknowledgments are conveyed to all parties who assist in the collection of research data. Secondly, to the Ministry of Research and Technology and the Ministry of Finance of the Republic of Indonesia through LPDP who gave scholarships BUDI-DN to the authors during the study.

References

- [1] Cutnell and Johnson K W 2009 *Physics 8th edition* (Colombus: John Willey and Sons, INC)
- [2] Tipler P A 1991 *Fisika untuk Sains dan Teknik edisi ketiga jilid 1* (Jakarta: Erlangga)
- [3] Mahmud M S 2001 Analisis Getaran pada Balok Baja dengan Peredam Struktur *Majalah Ilmiah Al-Jibra* **12** 41
- [4] J Poonyawatpornkul and P Wattanakasiwich 2012 High-speed video analysis of damped harmonic motion *IOP science* **48** 6
- [5] Susilo A, Yuniyanto M and Varianti V I 2012 Simulasi Gerak Harmonik Sederhana dan Osilasi Teredam pada Cassy-E 524000 *Indonesian Journal of Applied Physics* **2** 2
- [6] Triana C A and Fajardo F 2012 The influence of spring length on the physical parameters of simple harmonic motion *Eur. J. Phys.* **33**
- [7] Shamim S, Zia W and Anwar M S 2010 Investigating viscous damping using a webcam *Am. J. Phys.* **78** 433
- [8] Gonz´alez M I and Bol A 2006 Controlled damping of a physical pendulum: experiments near critical conditions *Eur. J. Phys.* **27** 257
- [9] Richey R C and Klein J D 2007 *Design and development research* (Mahwah NJ: Lawrence Erlbaum Associates Publisher)
- [10] Chai C S and Chen D 2004 A review on usability evaluation methods for instructional multimedia: an analytical framework *Retrieved from Instructional Journal of Multimedia* **31** 3