

BUKTI KORESPONDING PENULIS DENGAN
REVIEWER DAN PENGELOLA JURNAL

**Procedia Environmental Science, Engineering and
Management**

JURNAL INTERNASIONAL BEREPUTASI

Q3 PADA SCIMAGO JR DAN Q4 PADA SCOPUS

**Judul Paper : CONTROLLED ELECTRICAL CONDUCTIVITY (EC) OF
TOFU WASTEWATER AS A HYDROPONIC NUTRITION**



Procedia

Environmental Science, Engineering and Management

P - ESEM

[Home](#) [About this journal](#) [Issues](#) [Editorial Board](#) [Journal ethics](#) [Instructions for authors](#)

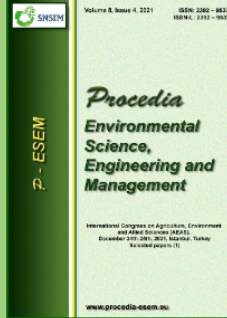

ISSN: 2392 - 9537
ISSN-L: 2392 - 9537
eISSN: 2392 - 9545

[Full cover](#)

[Current issue](#)

About

Procedia Environmental Science, Engineering and Management (P - ESEM) is a journal focusing on publishing papers selected from high quality conference proceedings, with emphasis on relevant topics associated to environmental science and engineering, as well as to specific management issues in the area of environmental protection and monitoring.

P - ESEM facilitates rapid dissemination of knowledge in the interdisciplinary area of environmental science, engineering and management, so conference delegates can publish their papers in a dedicated issue. This journal will cover a wide range of related topics, such as: environmental chemistry; environmental biology; ecology geoscience; environmental physics; treatment processes of drinking water and wastewater; contaminant transport and environmental modeling; remediation technologies and biotechnologies; environmental evaluations, law and management; human health and ecological risk assessment; environmental sampling; pollution prevention; pollution control and monitoring etc.

We aim to carry important efforts based on an integrated approach in publishing papers with strong messages addressed to a broad international audience that advance our understanding of environmental principles. For readers, the journal reports generic, topical and innovative experimental and theoretical research on all environmental problems. The papers accepted for publication in P - ESEM are grouped on thematic areas, according to conference topics, and are required to meet certain criteria, in terms of originality and adequacy with journal subject and scope.

Procedia Environmental Science, Engineering, and Management is covered by:

SCOPUS
EBSCO
INDEX COPERNICUS
GOOGLE SCHOLAR

BUKTI KORESPONDENSI PROCEEDIA

Procedia Environmental Science, Engineering and Management

Judul : Controlled Electrical Conductivity (Ec) Of Tofu Wastewater As A Hydroponic Nutrition

- SUBMIT (21 Juli 2019)
- REVISI 1 (6 Agustus 2019)
- REVISI 2 (5 September 2019)
- TERBIT DI PROCEEDIA (21 Desember 2019)

Daftar Lampiran

	Halaman
1. Indeks scopus	4
2. Indeks scimago	5
3. Undangan dan jadwal konferensi secara online	6
4. Submit jurnal	8
5. Pemberitahuan editor untuk memperbaiki naskah tahap 1	8
6. Balasan author bahwa naskah telah direvisi tahap 1	10
7. Pemberitahuan editor untuk membayar tagihan	10
8. Balasan author tagihan sudah dibayar	12
9. Pemberitahuan editor untuk memperbaiki naskah tahap 2	14
10. Balasan author bahwa naskah telah direvisi tahap 2	15
11. Naskah jurnal yang sudah direvisi tahap 1	16
12. Naskah jurnal yang sudah direvisi tahap 2	26
13. Sertifikat participant	35

Source details

[Feedback](#) >
 [Compare sources](#) >

Procedia Environmental Science, Engineering and Management

Scopus coverage years: from 2014 to Present
 Publisher: National Society of Environmental Science and Engineering (SNSIM)
 ISSN: 2392-9537 E-ISSN: 2392-9545
 Subject area: [Environmental Science: General Environmental Science](#)
 Source type: Journal

[View all documents](#) >
 [Set document alert](#)
[Save to source list](#)

CiteScore 2021	1.0
SJR 2021	0.409
SNIP 2021	0.525

[CiteScore](#)
[CiteScore rank & trend](#)
[Scopus content coverage](#)

Improved CiteScore methodology
 CiteScore 2021 counts the citations received in 2018-2021 to articles, reviews, conference papers, book chapters and data papers published in 2018-2021, and divides this by the number of publications published in 2018-2021. [Learn more](#) >

CiteScore **2021**
 $1.0 = \frac{248 \text{ Citations 2018 - 2021}}{247 \text{ Documents 2018 - 2021}}$
 Calculated on 05 May, 2022

CiteScoreTracker 2022
 $1.1 = \frac{274 \text{ Citations to date}}{259 \text{ Documents to date}}$
 Last updated on 05 November, 2022 - Updated monthly

CiteScore rank 2021

Category	Rank	Percentile
Environmental Science		
General Environmental Science	#173/228	24th

[View CiteScore methodology](#) >
 [CiteScore FAQ](#) >
 [Add CiteScore to your site](#)

About Scopus

- [What is Scopus](#)
- [Content coverage](#)
- [Scopus blog](#)
- [Scopus API](#)
- [Privacy matters](#)

Language

- [日本語版を表示する](#)
- [查看简体中文版本](#)
- [查看繁體中文版本](#)
- [Просмотр версии на русском языке](#)

Customer Service

- [Help](#)
- [Tutorials](#)
- [Contact us](#)

Procedia Environmental Science, Engineering and Management

Country [Romania](#) - [SJR Ranking of Romania](#)

Subject Area and Category [Environmental Science](#)
[Environmental Science \(miscellaneous\)](#)

Publisher [National Society of Environmental Science and Engineering \(SNSIM\)](#)

Publication type [Journals](#)

ISSN [23929545, 23929537](#)

Coverage [2014-ongoing](#)

3

H Index

Scope Procedia Environmental Science, Engineering and Management (P - ESEM) is a journal focusing on publishing papers selected from high quality conference proceedings, with emphasis on relevant topics associated to environmental science and engineering, as well as to specific management issues in the area of environmental protection and monitoring. P - ESEM facilitates rapid dissemination of knowledge in the interdisciplinary area of environmental science, engineering and management, so conference delegates can publish their papers in a dedicated issue. This journal will cover a wide range of related topics, such as: environmental chemistry; environmental biology; ecology geoscience; environmental physics; treatment processes of drinking water and wastewater; contaminant transport and environmental modeling; remediation technologies and biotechnologies; environmental evaluations, law and management; human health and ecological risk assessment; environmental sampling; pollution prevention; pollution control and monitoring etc. We aim to carry important efforts based on an integrated approach in publishing papers with strong messages addressed to a broad international audience that advance our understanding of environmental principles. For readers, the journal reports generic, topical and innovative experimental and theoretical research on all environmental problems. The papers accepted for publication in P - ESEM are grouped on thematic areas, according to conference topics, and are required to meet certain criteria, in terms of originality and adequacy with journal subject and scope.

[Homepage](#)

[How to publish in this journal](#)

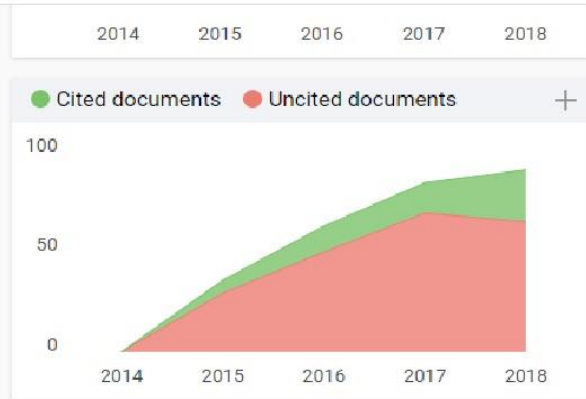
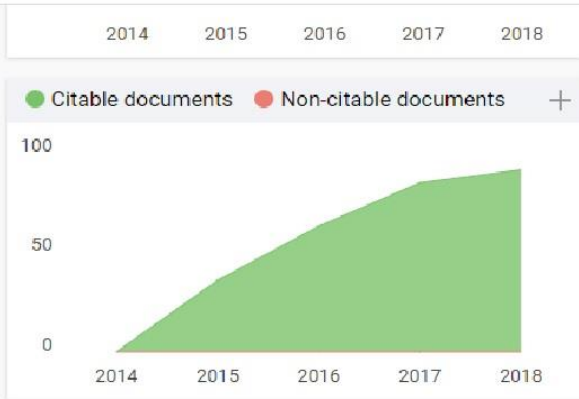

Procedia Environmental Science, Engineering and...

Q3 Environmental Science (miscellaneous) best quartile

SJR 2018 0.22

powered by scimagojr.com

← Show this widget in your own website

Just copy the code below and paste within your html code:

```
<a href="https://www.scimagojr.com" style="display: inline-block; border: 1px solid black; padding: 2px 5px;">https://www.scimagojr.com
```

Environmental Innovations online Conference. Agenda and Test play

Andrey Kuzmin <andrey.kuzmin@triacon.org>
Kepada: environment@triacon.org

17 September 2019 12.44

Dear Colleagues.

On Monday, September 23, 2019, our event will start.

The Agenda of the Conference published on the website <http://environment.triacon.org/gcal.html>

The Agenda was prepared in Google Calendar, so you can see the schedule in your local time.

Nevertheless, there is a PDF file attached to this email with Agenda in the time of UTC 0, so that you can check if all the time points are correct.

Each of the records in the Agenda on the website is clickable, so you can see additional details in it, including the end of the presentation, full author list and an abstract.

The schedule is almost completed, only little corrections can be made during the next couple of days. If this happens I send all of you an updating note.

We have participants from over the world. The "first" of you live in the UTC+7 (Far East), the opposite participants live in the UTC-7 :-). Nevertheless, we could collect altogether.

Thus, we are the champions! :-))

Organization issues.

All of you should prepare the presentation in the PowerPoint format.
All the presentations should be sent to me directly by email.

Please, title them with your Name, similar to the schedule, i.e., Yudakov_et_al.ppt.
If you have a few presentations during the conference, add a number to the name: Yudakov_et_al_01.ppt

Please, do not use any animations and/or movies in the presentations. For now, the system doesn't support animations.

Oral presentations take 15 minutes of the speaking and 5 minutes of the discussion.
We recommend using around 15 slides for this.

Poster presentations, in general, take around 1+ hour.
It can contain 1-3 slides of Power Point format.

Since the system allows magnifying the presentation you can put into the Poster slide a lot of small details. At the same time, we do not recommend using that approach for Oral presentations, because of the time limit.

Communications.

Since the bandwidth/speed of the Internet is not good for some of participants, we decided to restrict using the web-cameras during the conference. Only Headphones and Microphones for Presenters are allowed in time of their Presentation.

During the oral meetings all the microphones of the listeners will be muted by our moderators, except the current presenter. All the discussion after the presentation will be made by the chat in the main window. Please, do not use common chat during presentation.

You can use private chat with the person you want.
For Poster presentation each presenter will be a moderator and can control all other participants. Of course, our system moderators

will help you in any case.

Oral presentations will be scheduled in one web-room in sequence.

Poster presentations will be scheduled in a few separated parallel web-rooms for each of the presentations.

A list of the poster web-rooms will be sent to you before the conference starts. The process of the Poster presentation is the same,
like Oral ones

We recommend adding one blank slide to the Poster presentation for using it as a white board.

For now, a final gift for all of you:

<http://education.triacon.org/b/adm-yzw-vju>

<http://education.triacon.org/b/adm-vdy-n2u>

The links above are for test web-rooms.

Both identical.

You can "play" with them for this week without any limitation.

No registration need for the test rooms.

Just type your name and go ahead

Of course, please be careful and respectful to each other :-)))

You can upload your presentation, navigate it, using drawing tools, mute/unmute microphones - no limits. Please, only, do not use a

recording button. All your records will be deleted anyway.

Wish you good luck

Sincerely yours,

Dr. Andrey V.Kuzmin

Faithfully Yours

Dr.Andrey V.Kuzmin

tel: +380(95)5222222

e-mail: andrey.kuzmin@triacon.org

Skype: triacon

LinkedIn: <https://www.linkedin.com/in/andrey-kuzmin-653b2b1>

 **agenda.pdf**
84K

RE: DESIGN OF AUTOMATIC ELECTRICAL CONDUCTIVITY (EC) CONTROL SYSTEM FOR TOFU LIQUID WASTE AS HYDROPONIC NUTRIENT

17 pesan

Andrey Kuzmin <andrey.kuzmin@triacon.org>
Kepada: "Dr. Mareli Telaumbanua" <marelitelaumbanua@gmail.com>

26 Juli 2019 17.04

Dear Dr. Mareli Telaumbanua,

Thank you very much for allowing us to consider you such an interesting paper for our event.

I have carried out a preliminary review of your paper.
The general editorial opinion - your paper can be included in the Conference presentation pool.
However, major amendments are required before further consideration.

The main reason and the main amendment is following.
Your paper has been written from the point of view of electronic scheme solution.
It is a very good solution.

However, our conference and publications have a main topic "Environmental issues". Not the quality of the electronic design.

Thus, I recommend you to do the following.

You state in the paper that electrical conductivity of the tofu waste is an important parameter for the hydroponic nutrition.
However, it is not clear, why it is so important?
You should make a special focus on this explanation and proving.

It would be best if you could show how exactly change in electrical conductivity influences hydroponic nutrition or quality of the tofu liquid waste.
You should also add a description how this problem (control EC or quality of the fertilizer,) is solved at the moment.
Thus, your development will become actual.

Objective and Tasks of the research

The **Objective** of your research in this case will not be a Design, but to provide the quality of the fertilizer (or to provide the stable work of hydroponic nutrition system, or something other - you know better, why you need in the system you developed)

Then the **Tasks** will become to Design control system for reaching the abovementioned **Objective**.

The results:

The focus of them should be shifted, again, to reaching the Objective.

Thus, you should omit the detailed description of the electronic scheme design and its specifics.

Figure 3 and its description can be omitted.

Verification and Calibration results should be shortened to mention similar to this: Temperature sensor and EC sensor of the system were tested and their data were verified. Some of the verification results presented in the figures (not all the figures needed) It can be seen there is a good match between the sensors data and etalon sensor data. The calibration procedures for sensors developed were performed and correlations were got between the sensor data (mV) and the measured parameter (t, [°C]; EC, [mS/cm]). The maximal approximation error deviation is xxx% for temperature sensor and yyy% for EC sensor.

It would be better if you could add some results for the subject of how the developed system *improves/allows to reach the Objective*

Conclusions

No any details about accuracy, etc. Now your results are regarded to electronic solution, not to the Environmental issues.
After correction Objective and results, you can make Conclusion of the getting new control system which allows improving/reaching the **Objective**

Finally, after completing this corrections, you have to rewrite your Abstract with focus on the Environmental issues :-))) It can be close to Conclusion, but with other words.

Some minor corrections.

- Your equations are pictures, not equations. This is due to conversion the file from docx to doc. You should rewrite them in the Microsoft Equation Editor instead of MathType (default editor in MS Word 7+), and then save as doc file. This should help to correct.
- Please also describe all the abbreviations before they first mention in the text. Do not use any abbreviations in Abstract.
- Please use decimal points instead of decimal comma for decimal separator, and space instead of point in thousands separator: 6.374,55 ----> 6 374.55
- Please read the final text of the manuscript before submission. It would be better to check it with a native speaker.

I hope you understood me.

Please, do not hesitate to contact me if you have any question.

Please, also, write me a fast reply, will you correct your paper, or decide to withdraw?

It is important for me to understand if we can reply on you.

Looking forward to your reply soon

Best regards,
Andrey

From: Dr. Mareli Telaumbanua [mailto:marelitelaumbanua@gmail.com]

Sent: Sunday, July 21, 2019 5:56 PM

To: environment@triacon.org

Subject: New submission | Environment | DESIGN OF AUTOMATIC ELECTRICAL CONDUCTIVITY (EC) CONTROL SYSTEM FOR TOFU LIQUID WASTE AS HYDROPONIC NUTRIENT

Form Submission from <http://environment.triacon.org/submit.html>

Title : Dr. (PhD)

Name : Mareli Telaumbanua

Inst. : University of Lampung, Bandar Lampung, Indonesia

Web : <https://www.unila.ac.id/>

Phone : +6285261066502

Email : marelitelaumbanua@gmail.com

IP : 103.3.46.126

Paper Title :

DESIGN OF AUTOMATIC ELECTRICAL CONDUCTIVITY (EC) CONTROL SYSTEM FOR TOFU LIQUID WASTE AS HYDROPONIC NUTRIENT

Text :

This study applies the design of an automatic control system based on a microcontroller to control the Electrical Conductivity (EC) of tofu liquid waste to become suitable for plant growth, replacing hydroponic nutrient. The design of this automatic control device uses a variety of components, such as Arduino Uno microcontroller, EC sensor module, temperature sensor, relay, RTC, micro SD card, LCD, power supply, and pump. After the tool was designed, the temperature sensor and EC sensor will be calibrated and validated. The calibration results of the temperature sensor on the calibrator show a strong relationship with r-value = 99.92% so that the temperature equation is obtained. The results of the temperature sensor validation with the calibrator produce 0.16 of error value on the RMSE test. The EC calibration with the temperature sensor shows a strong relationship with the r-value = 99.22%, calibration of the EC sensor on the calibrator also shows a strong relationship with the r-value = 99.83%, but the calibration of the EC sensor on the pH sensor shows a weak relationship with the r-value = 14.63%. So that the function used to make equations into EC sensors. The result of the EC sensor validation on the calibrator produces 0.028 of error value on the RMSE test. The actuator performance test result shows an accuracy of 89.4%,

Keywords: Arduino uno, electrical conductivity, microcontroller, tofu liquid waste

Kepada: Febryan Kusuma Wisnu <febryankusumawisnu@gmail.com>

[Kutipan teks disembunyikan]

Mareli Telaumbanua <marelitaumbanua@gmail.com>
Kepada: Febryan Kusuma Wisnu <febryankusumawisnu@gmail.com>

26 Juli 2019 18.57

ini papernya...coba edit dr sini ya...

[Kutipan teks disembunyikan]

 **Procedia Mareli Telaumbanua_2019_Juli.doc**
1815K

Mareli Telaumbanua <marelitaumbanua@gmail.com>
Kepada: Andrey Kuzmin <andrey.kuzmin@triacon.org>

26 Juli 2019 19.19

thankyou very much for correction. i will correction it less then 48 hours, and send it to andrey.kuzmin@triacon.org

Thankyou

[Kutipan teks disembunyikan]

Mareli Telaumbanua <marelitaumbanua@gmail.com>
Kepada: Andrey Kuzmin <andrey.kuzmin@triacon.org>

6 Agustus 2019 05.40

Sory to late...

This is revised of our paper.

we have revised this paper as requested

The title "**CONTROLLED ELECTRICAL CONDUCTIVITY (EC) OF TOFU WASTEWATER AS A HYDROPONIC NUTRITION**"

Thank you

[Kutipan teks disembunyikan]

 **Procedia Mareli Telaumbanua edit_1.doc**
867K

Andrey Kuzmin <andrey.kuzmin@triacon.org>
Kepada: Mareli Telaumbanua <marelitaumbanua@gmail.com>

6 Agustus 2019 12.38

Excellent!

For now this paper content is much close to the conference and journal!

Thank you fo a good job.

Now only couple corrections.

1. Your manuscript is typed in the MS Word of version 2007+ which has a native format - docx. You have converted the manuscript to the doc format. Thank you. However as a result of those conversion all the equations in your paper became pictures.

I would like to ask you to make following:

Please, retype all the equations in you DOCx manuscript with use Microsoft Equation Editor, instead of MathType, which is used by default in the nevest versions of the Ms Word

As all your formulas will be retyped in Equation Editor format there won't be errors at the conversion paper from DOCx to DOC. All of them will be equations as well in DOC paper.

2. The next ask is regarded to figures.

Figures 1 and 2 has poor qualtiy. I would be grateful, if you could send me them in high quality. To be sure the picture is a good qualty please make its width at least 1417 px. (it corresponds to 12 cm width of 300 dpi)

In addition, you add Figure 9 (Hydroponic Installation). But it doesn't have Caption. Also all the numbers in the table Information would be great to indicate in the Figure ;-)

That is all.

You paper is accepted with those corrections.

Payment

Please, use Western Union money transfer for this.

I will keep **140\$** fee for you till wednesday, 07 August 2019.

After that day it will be increased to 170\$ + 2\$ for each day after 04 August (we have this payment scheme)

You can find WU agent location near you by the link:

<https://www.westernunion.com/ID/en/find-locations.html>

The recipient's data for the transfer are following

Receiver's country:	Ukraine
Receiver's city (if need):	Dnipro
Send amount:	140\$
Receive amount:	140\$
How does your receiver want the money?	Cash at WU location
Receiver's name:	Andrey Kuzmin
Receiver's phone (if need)	+380 (97) 602 5538
Additional information can be need	
Institution:	National Academy of Sciences in Ukraine
Address:	Ukrainska str., 13/15, apt. 2 Dnipro Ukraine

After completing the money transfer, please, send me by email the following information:

1. **MTCN** – money transfer control number
2. **Sent amount** in USD
3. **Full Name** of the sender
4. **Country** from where the money was transferred.

Looking forward for your reply soon

Please, do not hesitate to contact me if you have any questions

Sincerely yours,

Andrey

From: Mareli Telaumbanua [mailto:marelitelaumbanua@gmail.com]

Sent: Tuesday, August 06, 2019 1:40 AM

To: Andrey Kuzmin

Subject: Re: DESIGN OF AUTOMATIC ELECTRICAL CONDUCTIVITY (EC) CONTROL SYSTEM FOR TOFU LIQUID WASTE AS HYDROPONIC NUTRIENT

[Kutipan teks disembunyikan]

Mareli Telaumbanua <marelitelaumbanua@gmail.com>
Kepada: Febryan Kusuma Wisnu <febryankusumawisnu@gmail.com>

7 Agustus 2019 10.43

----- Forwarded message -----

Dari: **Andrey Kuzmin** <andrey.kuzmin@triacon.org>

[Kutipan teks disembunyikan]

[Kutipan teks disembunyikan]

Febryan Kusuma Wisnu <febryankusumawisnu@gmail.com>

7 Agustus 2019 13.23

Kepada: Mareli Telaumbanua <marelitaumbanua@gmail.com>

Proceeding MAJU JAYA

[Kutipan teks disembunyikan]

 **Procedia Mareli Telaumbanua edit.docx**
504K

Mareli Telaumbanua <marelitaumbanua@gmail.com>
Kepada: Andrey Kuzmin <andrey.kuzmin@triacon.org>

7 Agustus 2019 19.49

Thank you for the notification.
I will tidy up the writing and send it in a few moments

I have made a payment of 140 USD.
in the name of Febrian. Febrian is one of the authors of this journal.
here is proof of delivery.

Thank you very much

[Kutipan teks disembunyikan]



IMG-20190807-WA0068.jpg
109K

Andrey Kuzmin <andrey.kuzmin@triacon.org>
Kepada: Mareli Telaumbanua <marelitaumbanua@gmail.com>

7 Agustus 2019 21.30

Dear Dr. Mareli,

Thank you very much for your information.
Unfortunately, there is some problems with your transfer - it cannot be received due to some incorrect information was filled.
I don't know what exactly. In addition, this caused triple for last month (since the 06 July). It seems, we will break our agreement with WU.

Please, do the following
Your Sender Febrian should go to the location from where he sent money and ask to REFUND transfer.
After that, please, let me know.
We try to use Moneygram.
However, we did not work with that system yet.
I ask you to do the MoneyGram transfer after the WU will Refund transfer.
The requisites are the same.
The procedure is very close.
<http://global.moneygram.com/id>

Only instead of "Cash at WU location" - should be **Cash at MoneyGram location.**

Sorry for that happend :-)

Yours,
Andrey

From: Mareli Telaumbanua [mailto:marelitelaumbanua@gmail.com]

Sent: Wednesday, August 07, 2019 3:49 PM

[Kutipan teks disembunyikan]

[Kutipan teks disembunyikan]

Mareli Telaumbanua <marelitelaumbanua@gmail.com>
Kepada: Andrey Kuzmin <andrey.kuzmin@triacon.org>

7 Agustus 2019 22.20

Oh..oke..

I will try to refund it , tommorow,,because, in my country, this time is night.
After refund it, i try to send using monaygram.
I will telling to you, if payment success.

Thank you for information .

[Kutipan teks disembunyikan]

Andrey Kuzmin <andrey.kuzmin@triacon.org>
Kepada: Mareli Telaumbanua <marelitelaumbanua@gmail.com>

7 Agustus 2019 22.22

Thank you, dear

[Kutipan teks disembunyikan]

Andrey Kuzmin <andrey.kuzmin@triacon.org>
Kepada: Mareli Telaumbanua <marelitelaumbanua@gmail.com>

12 Agustus 2019 12.52

Dear Dr. Mareli,

Could you, please, make payment again as soon as possible.
Since we have to go ahead with the Conference publications.
Please, use MoneyGram service, **DO NOT USE WesternUnion**

Sincerely yours,
Andrey

From: Andrey Kuzmin [mailto:andrey.kuzmin@triacon.org]

Sent: Wednesday, August 07, 2019 6:22 PM

To: Mareli Telaumbanua

[Kutipan teks disembunyikan]

[Kutipan teks disembunyikan]

Andrey Kuzmin <andrey.kuzmin@triacon.org>
Kepada: Mareli Telaumbanua <marelitelaumbanua@gmail.com>

12 Agustus 2019 13.10

<http://global.moneygram.com/id/moneygram-lokasi>

Find location near you
Requisites:

Receiver's country:	Ukraine
Receiver's city (if need):	Dnipro
Send amount:	140\$
Receive amount:	140\$
How does your receiver want the money?	Cash
Receiver's name:	Andrey Kuzmin
Receiver's phone (if need)	+380 (97) 602 5538
Additional information can be need	
Institution:	National Academy of Sciences in Ukraine
Address:	Ukrainska str., 13/15, apt. 2 Dnipro Ukraine

After completing the money transfer, please, send me by email the following information:

1. **Reference Number** – money transfer control number
2. **Sent amount** in USD
3. **Full Name** of the sender
4. **Country** from where the money was transferred.

From: Andrey Kuzmin [mailto:andrey.kuzmin@triacon.org]
Sent: Monday, August 12, 2019 8:53 AM
To: 'Mareli Telaumbanua'
Subject: RE: DESIGN OF AUTOMATIC ELECTRICAL CONDUCTIVITY (EC) CONTROL SYSTEM FOR TOFU LIQUID WASTE AS HYDROPONIC NUTRIENT
Importance: High

Dear Dr. Mareli,

Could you, please, make payment again as soon as possible.
Since we have to go ahead with the Conference publications.
Please, use MoneyGram service, **DO NOT USE WesternUnion**

Sincerely yours,
Andrey

From: Andrey Kuzmin [mailto:andrey.kuzmin@triacon.org]
Sent: Wednesday, August 07, 2019 6:22 PM
To: Mareli Telaumbanua
[Kutipan teks disembunyikan]

[Kutipan teks disembunyikan]

Andrey Kuzmin <andrey.kuzmin@triacon.org>
Kepada: Mareli Telaumbanua <marelitelaumbanua@gmail.com>

5 September 2019 11.43

Dear Dr. Mareli,

I hope all is well.
We have found some issue with your equations.
They are pictures
Could you, please, correct them asap?
They should be type in the Equation Editor (not MathType)
p.5

Sincerely yours,

Andrey



28.Telaumbanua.doc
872K

Mareli Telaumbanua <marelitelaumbanua@gmail.com>
Kepada: Febryan Kusuma Wisnu <febryankusumawisnu@gmail.com>

5 September 2019 11.54

----- Forwarded message -----

Dari: **Andrey Kuzmin** <andrey.kuzmin@triacon.org>

[Kutipan teks disembunyikan]

[Kutipan teks disembunyikan]



28.Telaumbanua.doc
872K

Mareli Telaumbanua <marelitelaumbanua@gmail.com>
Draf

24 September 2022 19.16

[Kutipan teks disembunyikan]



DESIGN OF AUTOMATIC ELECTRICAL CONDUCTIVITY (EC) CONTROL SYSTEM FOR TOFU LIQUID WASTE AS HYDROPONIC NUTRIENT*

Mareli Telaumbanua^{1**}, Sugeng Triyono¹, Agus Haryanto¹, Febryan Kusuma Wisnu¹

¹*Department of Agricultural Engineering, Faculty of Agriculture, University of Lampung*

Abstract

This study applies the design of an automatic control system based on a microcontroller to controls the Electrical Conductivity (EC) of tofu liquid waste to become suitable for plant growth, replacing hydroponic nutrient. The design of this automatic control device uses a variety of components, such as Arduino Uno microcontroller, EC sensor module, temperature sensor, relay, RTC, micro SD card, LCD, power supply, and pump. After the tool was designed, the temperature sensor and EC sensor will be calibrated and validated. The calibration results of the temperature sensor on the calibrator show a strong relationship with r-value = 99.92% so that the temperature equation is obtained. The results of the temperature sensor validation with the calibrator produce 0.16 of error value on the RMSE test. The EC calibration with the temperature sensor shows a strong relationship with the r-value = 99.22%, calibration of the EC sensor on the calibrator also shows a strong relationship with the r-value = 99.83%, but the calibration of the EC sensor on the pH sensor shows a weak relationship with the r-value = 14.63%. So that the function used to make equations into EC sensors. The result of the EC sensor validation on the calibrator produces 0.028 of error value on the RMSE test. The actuator performance test result shows an accuracy of 89.4%,

Keywords: Arduino uno, electrical conductivity, microcontroller, tofu liquid waste

1. Introduction

In Indonesia, the tofu industry has provided employment and economic benefit as their positive value. On the other hand, the negative side of this industry is the environmental pollution from residual waste which wasn't managed properly (Sadzali, 2010). Table 1 shows the value of COD and BOD from tofu and soybean industrial waste.

* Selection and peer-review under responsibility of the EIAETM

** Corresponding author: mareli.telaumbanua@fp.unila.ac.id and marelitelaumbanua@gmail.com

Table 1. Characteristic of tofu and tempe liquid waste

Parameter	Tofu Liquid Waste	Tempe Liquid Waste
COD (mg/L)	6.374,55	14.459,95
BSD (mg/L)	3.912,27	6.218,42

Source : Said, et.al. (1999)

The tofu liquid waste has produced by filtered soybean essence from protein clumping process. This liquid waste contains organic materials such as protein, fat, and carbohydrate, along with inorganic materials like Ca, Fe, Cu, Na, N, P, K, Cl, and Mg (Tabel 2) (Ernawati, 2014). The protein content from the liquid waste will release N compound if they were decomposed by soil microbes, then the N compound can be absorbed by the plant roots (Asmoro, et al., 2008). This process shows that tofu liquid waste has the potential to become an organic fertilizer (Rosalina, 2008).

Table 2. Nutrient content in tofu and commercial fertilizers

Parameter	Tofu Solid Waste	Solid Compost of Green Valley	Tofu Liquid Waste	Commercial Liquid Fertilizer Tristan
N (%)	1,24	1,44	0,27	0,42
P2O5 (ppm)	5,54	2,37	2,85	0,28
K2O (%)	1,34	3,03	0,29	0,08
Protein (%)	7,72	-	1,68	-

Source : Asmoro et al. (2008)

The utilization of waste to become organic fertilizer is an effort to resolve the environmental pollution problem. The organic content of this waste can be the organic nutrient for microbes growth. Novita (2009) shows that 25% concentrate of tofu liquid waste provides the best value for all Sawi (*Brassica juncea L.*) growth parameter with once a week sprinkling. The utilization of 20% tofu liquid waste concentration from 1 kg of soil can triple the production of Petsai (*Brassica chinensis*), but this research was held on soil media (Asmoro et al., 2008).

On the hydroponic system, nutrition and water were dissolved for the plant growth. Hydroponic nutrition is vulnerable from EC (Electrical Conductivity) and pH EC changes. Electrical conductivity is influenced by the thickness of the nutrient solution. The higher thickness value of nutrients provides the greater EC value, and vice versa. Furthermore, the EC changes were influenced by environmental factors such as temperature, sunlight intensity, wind, and humidity (Untung, 2000 ; Suhardiyanto, 2009). But, the temperature factor has the most significant effect to increase EC value. Uncontrollable EC will interrupt the plant growth, which is needed to be controlled by a system that can adjust EC value according to the plant needs. One of the control system application to control EC is to use a microcontroller. A microcontroller has an output pin and an input pin that can be used as a signal receiver and a voltage supply to other objects (Telaumbanua, et al., 2018). The ATmega 328 microcontroller used in this study is a minicomputer inside a chip that can be programmed to control sensors and actuators for EC value control (Telaumbanua, et al., 2014).

2. Objectives

This study aims to apply a design of the Electrical Conductivity (EC) control system of tofu liquid waste on hydroponic media. The EC of tofu liquid waste is controlled to be suitable for plant growth, replacing hydroponic nutrition. To design this system, sensors that have high accuracy are needed. To get the sensor validation value and the high accuracy of the sensor control system, the effect of temperature on the conductance value is considered in the calibration process. High-temperature accuracy affects the level of electrical conductivity (EC) in tofu wastewater. If the EC value is too high, the plant will be poisoned. While too low EC value causes nutrient deficiencies that inhibit plant growth.

3. Outline of the work

This study divided in four main parts :

- Tool design
- Calibration and Validation Procedure of Temperature Sensor
- Calibration and Validation Procedure of EC Sensor
- Performance test

4. Materials and methods

This research was held at the Agricultural Engineering Department of the University of Lampung. The tools used in this study are:

1. The control system component is an Arduino Uno ATmega 328 microcontroller, Arduino Uno shield, EC meter sensor module with a measurement range of 1mS /cm - 20 mS /cm, DS18B20 temperature sensor, Real-Time Clock (RTC) type DS1307, Micro SD card module, 4 channel relay module and 2 channels, 6 single socket, jumper cable, 20 x 4 LCD, laptop, power supply, regulator, transistor, resistor, PCB board, breadboard, EC meter Jenway model 4510.
2. Hydroponic components consist of 2 nutrient storage tanks, waste buckets, water buckets, 6 aquarium pumps, aerators, and pipes.
3. AB mix, water, and tofu liquid waste.

4.1. Tool Design

Arduino Uno microcontroller has connected with supporting components such as EC sensor module, temperature sensor, relay, RTC, micro SD card, LCD, power supply, and pump. Then the command program is entered into the Arduino IDE software which has been specifically designed for automatic EC control. The EC sensor is integrated with a microcontroller (Arduino) (figure 1). Next, the microcontroller is integrated with an actuator pump to control the EC value. In the design, the output pin on the EC module is connected to the analog pin A0, and the pump is connected with a digital pin 3 on Arduino UNO 328. The design block diagram can be seen in Figure 2.

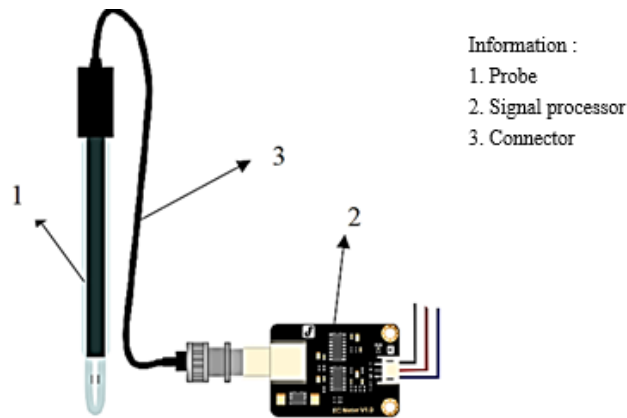

Information :
 1. Probe
 2. Signal processor
 3. Connector

Figure 1. EC sensors are integrated into the microcontroller

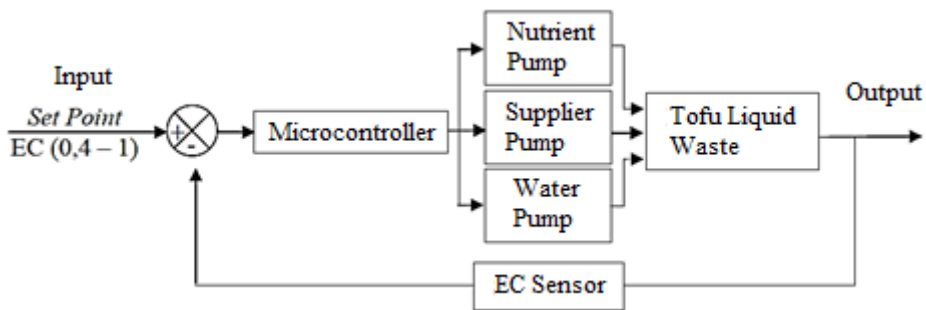

Figure 2. Block Diagram of Control System Design

4.2. Design Criteria

This study was designed to control EC in susceptible 0.4 mS / cm - 1.0 mS / cm. The EC value is obtained from the sensor placed on the surface of the nutrient solution, then the value is sent to the microcontroller. The microcontroller will execute according to the EC sensor output value by giving an order to the actuator, namely the water pump and tofu liquid waste pump. If the EC value is less than vulnerable (<0.4 mS/cm), the tofu liquid waste pump will light up, but if it is more than vulnerable (> 1.0 mS/cm), the water pump will turn on and enter the nutrient storage tub until the EC value returns to vulnerable.

4.3. Calibration and Validation Procedure of Temperature Sensor

Temperature sensor calibration is calculated by inserting the sensor and calibrator into the distilled water solution which is heated at 40°C. Then the readable output values on the sensor and temperature calibrator are recorded every one minute for one hour. The calibration results are made relationship graphs and regression analysis to obtain the equation functions that will be included in the Arduino IDE software. Validation is calculated to prove the suitability of the sensor output value and the calibrator. The procedure of the validation process is almost the same as calibration, the difference is that the output value from the sensor is the result of the equation function obtained from the regression analysis.

4.4. Calibration and Validation Procedure of EC Sensor

EC sensor calibration is calculated by the dependent EC variables and independent variable relation (temperature, mV, and pH). Initially, the EC sensor and EC kalibrator are inserted into the same AB mix solution. The calibration process was calculated using 4

samples of EC values, which are 1 mS/cm, 2 mS/cm, 3 mS/cm, and 4 mS/cm, then each sample was heated using a hot plate at 28°C, 31°C, 33°C, and 35°C. After that, the sensor output values and the calibrator are recorded then grouped into variable temperature (oC), EC meter, EC sensor (mV), and pH meter. The calibration results are entered into the regression analysis to find the equation values that will be used in the research into the Arduino IDE program. The validation process is almost the same as the calibration stage, but what distinguishes it is the output value of the sensor is in units of mS / cm ready compared to the calibrator. Afterward, both the RMSE test and the temperature sensor and EC sensor are used to see the sensor error value for the calibrator.

$$RMSE = \sqrt{\frac{1}{n} \sum_{i=1}^n (O_i - P_i)^2}$$

- N = amount of data
- O_i = observation data
- P_i = prediction data (Sugiyono, 2007).

3.5. Performance Test

Performance tests are performed to find the value of accuracy, average control time, system response, and system stability. Accuracy values are sought with equations (2.1), (2.2), and (2.3).

$$\text{Inaccuracy} = \frac{\bar{X}}{SP} \times 100 \% \dots\dots\dots (2.1)$$

$$\bar{X} = \frac{\sum_{i=1}^n |SP - NA_i|}{n} \dots\dots\dots (2.2)$$

Information :

- \bar{X} = average value
- SP = setting point value
- NA = actual value
- n = amount of data

$$\text{Accuracy} = 100\% - \text{Inaccuracy (in \%)} \dots\dots\dots (2.3)$$

The average control time is observed to find out how fast the device can control the value for the desired vulnerability.

5. Results and discussion

5.1. Tool Design

The design of this automatic control device (Figure 3) uses a variety of components, such as Arduino Uno microcontroller, EC sensor module, temperature sensor, relay, RTC, micro SD card, LCD, power supply, and pump.

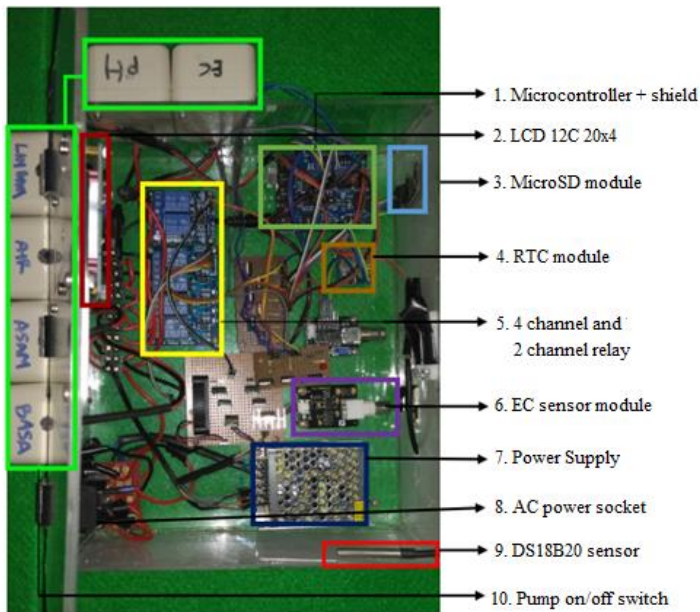

Figure 3. Set of Tools

The microcontroller is connected with components that have their respective functions. Arduino Uno microcontroller serves as the brain to process all activities that take place. The Arduino Uno microcontroller can operate at 5V-12V voltage. The function of the temperature sensor and EC are to read the temperature of the solution and the EC value of the solution. RTC is used to record the time (hours, minutes, seconds) of each process that occurs during the process of the microcontroller. The microSD card module stores all data from the process that occurs, both data from sensors and RTC. The function of LCD functions is to display signal output from the sensor and RTC. The power supply has the function to change the AC current from PLN to a 12V voltage DC current as a microcontroller voltage source. Relay has the function as an automatic I/O switch for pumps according to the input signal from sensor readings. The pump has the function as an actuator to drain tofu liquid waste according to the command signal from the microcontroller.

5.2. Calibration and Validation of Temperature Sensor

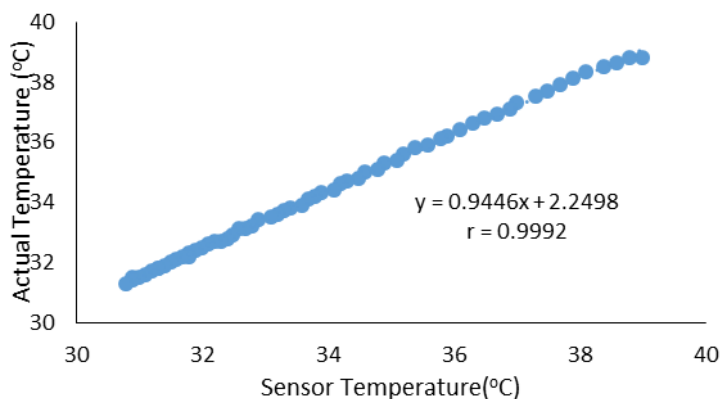

Figure 4. Calibration of Temperature Sensor

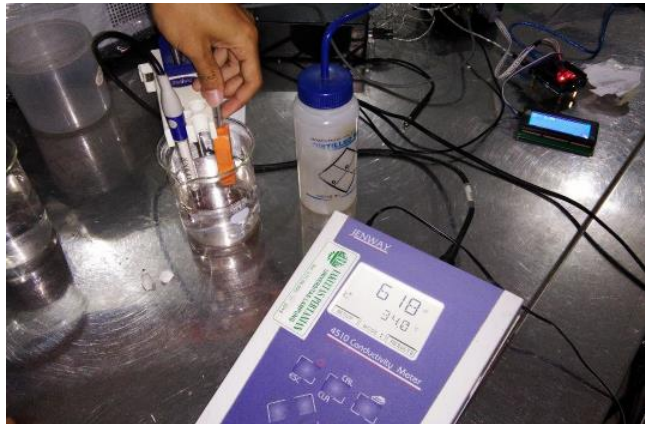

Figure 5. Calibration Process of EC Sensor

The DS18B20 temperature sensor is a digital sensor so that the output value is displayed in Celsius degrees. Temperature calibration result shows a coefficient r-value of 0.9992 which indicates that both relations are strong. From Figure 4, the y equation is used as a temperature sensor correction factor, i.e. :

$T = (0.9446 * \text{temperature sensor}) + 2,2498$. Next step is the validation process.

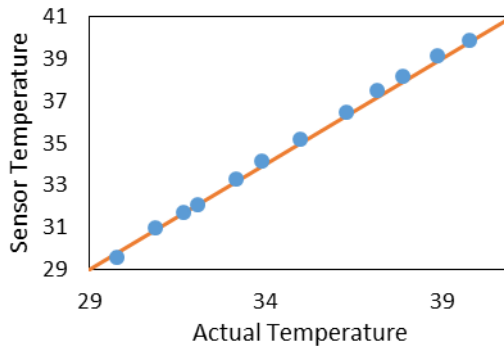

Figure 6. Validation of Temperature Sensor

The temperature sensor validation shows good results because it is in the diagonal line forming a 45 ° angle (Figure 6). The error value of the temperature sensor obtained from the RMSE test is 0.16. The EC sensor calibration process with an EC meter calibrator can be seen in Figure 5.

5.3. Calibration and Validation of EC Sensor

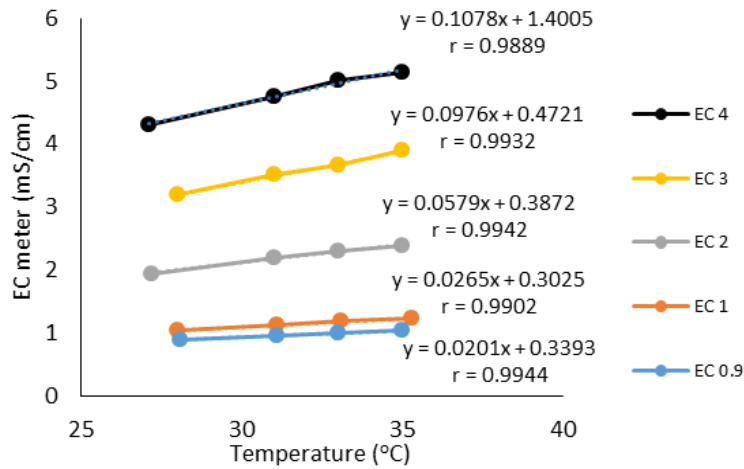

Figure 7. EC and Temperature Calibration

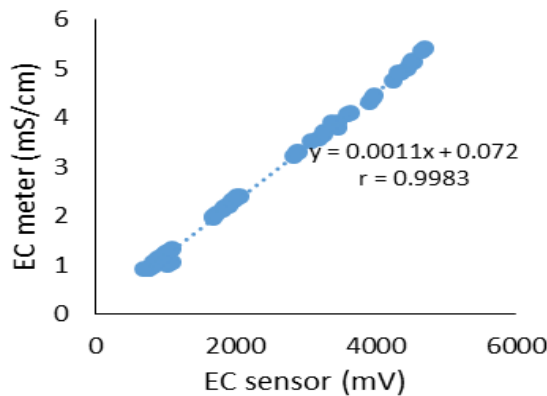

Figure 8. Calibration of EC Sensor and Calibrator

From the EC calibration process, it is obtained that the influential independent variables are temperature and EC (mV) sensor, seen from the r-value coefficient is close to 1, while the pH shows a weak or has no relationship effect because the r-value coefficient is far from 1. Then the temperature and EC variables (mV) are included in the regression analysis, so that the equation is obtained as a correction factor, i.e.

$$EC = (0.0015328 * \text{temperature}) + (0.0054178 * \text{mV}) + 0.024268.$$

Next step is the validation of EC sensor. Calibration values can be seen in figure 7-9.

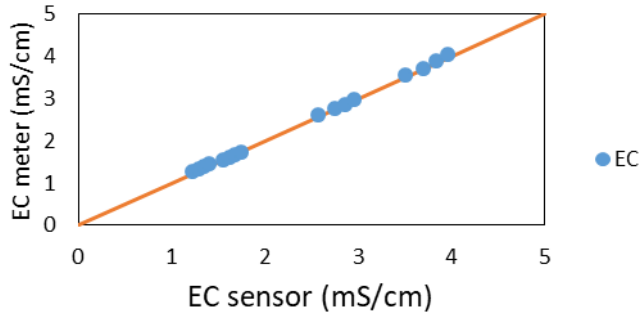

Figure 9. EC Sensor Validation

Figure 9 shows the output value of the sensor is very good, because it is on the diagonal line. The error value of the EC sensor is obtained from the RMSE test which is 0.028.

5.4. Performance Test Result

The results of tool performance are very important to determine the suitability of the tool against the design criteria. Test results for accuracy performance, average control time, system response, and system stability. Accuracy is calculated from equation (2.1), (2.2), (2.3)

Calculates the accuracy of the actuator that exceeds the upper limit.

$$\frac{\bar{X}}{SP} \times 100 \%$$

$$\bar{X} = \frac{\sum_{i=1}^n |SP - N_{Ai}|}{n}$$

$$\bar{X} = 0,194 \quad SP = 1$$

$$\text{Inaccuracy} = \frac{0,194}{1} \times 100 = 19,4\%$$

$$\text{Accuracy} = 100\% - 19,4\% = 80.6\%$$

Calculates the accuracy of the actuator that crosses the lower limit.

$$\bar{X} = 0,004 \quad SP = 0,4$$

$$\text{Inaccuracy} = \frac{0,004}{0,4} \times 100 = 1\%$$

$$\text{Accuracy} = 100\% - 1\% = 99\%$$

$$\text{Average Accuracy} = \frac{80,6 + 99}{2} = 89,40 \%$$

Tabel 3. Accuracy test

Information	(%)
Accuracy of actuator on SP (>1)	80.6
Accuracy of actuator on SP (< 0,4)	99
Average accuracy	89,40

Based on Table 3, the accuracy of the actuator in controlling the EC value that crosses the limit is considered good, because the average calculated result is 89.40%.

6. Conclusion

Based on this research that has been done, the following conclusions are obtained:

- The automatic EC control system works well because it matches the specified design criteria.

- The calibration results of the temperature sensor on the calibrator show a strong relationship with r-value = 99.92% so that the temperature equation is obtained, $T = (0.9446 * \text{sensor temperature}) + 2.2498$.
- The results of the temperature sensor validation with the calibrator produce 0.16 of error value on the RMSE test.
- The EC calibration with the temperature sensor shows a strong relationship with the r-value = 99.22%, calibration of the EC sensor on the calibrator also shows a strong relationship with the r-value = 99.83%, but the calibration of the EC sensor on the pH sensor shows a weak relationship with the r-value = 14.63%. So that the function used to make equations into EC sensors, which is from temperature and mV $EC = ((0.0015328 * \text{temperature}) + (0.0054178 * \text{mV}) + 0.024268$.
- The result of the EC sensor validation on the calibrator produces 0.028 of error value on the RMSE test.
- The actuator performance test result shows an accuracy of 89.4%.

7. References

- Asmoro, Y., Suranto, and D. Sutoyo. 2008. The Utilization of Tofu Waste for Petsai (Brassica Chinensis) improvement. *Journal of Biotechnology*. 5 (2): 51-55.
- Ernawati, D. 2014. *The Effect of Tofu Liquid Waste on Hydroponic Tomato (Lycopersicum Esculentum Mill) Vegetative Growth*. Faculty of Biology. Muhammadiyah University. Semarang.
- Novita, F.D. 2009. The Effect of Frequency and Concentration of Tofu Liquid Waste on Sawi Plant Growth. *Thesis*. Department of Biology. Faculty of Science and Technology. Malang State Islamic University. Malang.
- Rosallina, Nur. 2008. The Effect of Concentration and Frequency of Tempe Liquid Waste as Organic Fertilizer for Growth and Tomatoes (Lycopersicum esculentum Mill.) Result. *Thesis*. Malang: Biology Department Malang State Islamic University. Poor.
- Rosallina, Nur. 2008. Pengaruh Konsentrasi dan Frekuensi Penyiraman Air Limbah Tempe sebagai Pupuk Organik terhadap Pertumbuhan dan Hasil Tomat (*Lycopersicum esculentum* Mill.). *skripsi*. Malang: Jurusan Biologi Universitas Islam Negeri Malang. Malang.
- Sadzali, I. 2010. The Potential of Tofu Waste as Biogas. *Journal of University of Indonesia for the Nation Series of Health*. Science and Technology 1 (1): 64–65.
- Said, N, I., Indriatmoko, H., Raharjo, N., and Herlambang, A. 1999. Technology of Processing Tofu-Tempe Waste by Anaerobic and Aerobic Biofilter Processes. BPPT. Jakarta.
- Suhardiyanto, H. 2009. Hydroponic Technology for Plant Cultivation. Department of Agricultural Engineering. Faculty of Agricultural Technology IPB. Bogor.
- Telaumbanua, M., B. Purwantana, and L. Sutiarmo. 2014. Design and Construction of Actuators for Micro Climate Control in Greenhouses for Sawi (*Brassica rapa* Var. *Parachinensis* L.) Cultivation. *J. Agritech*. 34 (2): 213-222.
- Telaumbanua, M., Anggraini, R., Sasongko, F.I., Fitri, A, Sari, R. F. M., Waluyo, S (2018). Control System Design for Rat Pest Repellent in the Rice Field Using a Modified ATmega328 Microcontroller Modified with Ultrasonic Sound Wave. *International Journal of Engineering Inventions*. 7(8) : 22-28.
- Untung, O. 2000. *Hidroponik Sayuran System NFT (Nutrient Film Tehknique)*. Penebar Swadaya. Jakarta.



CONTROLLED ELECTRICAL CONDUCTIVITY (EC) OF TOFU WASTEWATER AS A HYDROPONIC NUTRITION*

Mareli Telaumbanua^{1**}, Sugeng Triyono¹, Agus Haryanto¹, Febryan Kusuma Wisnu¹

¹*Department of Agricultural Engineering, Faculty of Agriculture, University of Lampung*

Abstract

Tofu wastewater has the potential to become an organic fertilizer because of its protein content. The utilization of tofu wastewater into organic fertilizer is an effort to resolve the environmental pollution issue. This study used tofu wastewater obtained from local tofu producer in the city of Bandar Lampung, Indonesia. Tofu wastewater is diluted using clean water in a ratio of 1:5, 1:10, and 1:20. Electrical conductivity (EC) settings are carried out using an automatic control system based on a self-assembled microcontroller. Controlling the EC will be beneficial because a hydroponic system depends on the minerals and ions content of the nutrient solution. EC can deliver electric ions from the nutrient solution to the plant roots. The EC value would affect the photosynthesis speed rate, enzyme activities, and ion absorption of the plant roots. This study applies the design of an automatic control system based on a microcontroller that controls the EC of tofu wastewater to become suitable for plant growth in a hydroponic system. The results showed that the best dilution of distilled water and tofu wastewater for Mustard greens in a hydroponic system are using a 1:20 ratio with an EC value of 0.57 mS/cm.

Keywords: Electrical conductivity, microcontroller, tofu wastewater

1. Introduction

In Indonesia, tofu industries have provided employment and economic benefit from their positive value. On the other hand, the negative side of this industry is environmental pollution from residual waste, which has not appropriately managed (Sadzali, 2010). Table 1 shows the value of COD and BOD from tofu and soybean industrial waste.

* Selection and peer-review under responsibility of the EIAETM

** Corresponding author: mareli.telaumbanua@fp.unila.ac.id and marelitelaumbanua@gmail.com

Table 1. Characteristic of tofu and tempe liquid waste

Parameter	Tofu Wastewater	Tempe Wastewater
COD (mg/L)	6 374,55	14 459,95
BSD (mg/L)	3 912,27	6 218,42

Source : Said, et.al. (1999)

The tofu wastewater was produced by filtered soybean essence from the protein clumping process. This liquid waste contains organic materials such as protein, fat, and carbohydrate, along with inorganic materials like Ca, Fe, Cu, Na, N, P, K, Cl, and Mg (Tabel 2) (Ernawati, 2014). The protein content from the liquid waste will release N compound if soil microbes decomposed them, then the N compound can be absorbed by the plant roots (Asmoro et al., 2008). This process shows that tofu wastewater has the potential to become an organic fertilizer (Rosalina, 2008).

Table 2. Nutrient content in tofu and commercial fertilizers

Parameter	Tofu Solid Waste	Solid Compost of Green Valley	Tofu Wastewater	Commercial Liquid Fertilizer Tristan
N (%)	1,24	1,44	0,27	0,42
P2O5 (ppm)	5,54	2,37	2,85	0,28
K2O (%)	1,34	3,03	0,29	0,08
Protein (%)	7,72	-	1,68	-

Source : Asmoro et al. (2008)

The utilization of waste to become organic fertilizer is an effort to resolve the environmental pollution problem. The organic content of this waste can be the organic nutrient for microbes growth. Novita (2009) shows that 25% concentrate of tofu liquid waste provides the best value for all Mustard greens (*Brassica juncea* L.) growth parameter with once a week sprinkling. The utilization of 20% tofu liquid waste concentration from 1 kg of soil can triple the production of Petsai (*Brassica Chinensis*), but this research was held on soil media (Asmoro et al., 2008).

On the hydroponic system, nutrition and water dissolved for the plant growth. Hydroponic nutrition is vulnerable from EC (Electrical Conductivity) and pH EC changes. EC influenced by the thickness of the nutrient solution. The higher thickness value of nutrients provides the more excellent EC value, and vice versa. Furthermore, the EC changes influenced by environmental factors such as temperature, sunlight intensity, wind, and humidity (Untung, 2000; Suhardiyanto, 2009). However, the temperature factor has the most significant effect of increasing EC value. Uncontrollable EC will interrupt the plant growth, which is needed to be controlled by a system that can adjust EC value according to the plant needs. One of the control system application to control EC is to use a microcontroller. A microcontroller has an output pin and an input pin that can be used as a signal receiver and a voltage supply to other objects (Telaumbanua et al., 2018). The ATmega 328 microcontroller used in this study is a minicomputer inside a chip that can be programmed to control sensors and actuators for EC value control (Telaumbanua et al., 2014).

2. Objectives

Using tofu wastewater as hydroponic nutrition can be done by adjusting the EC value contained in the mixture of wastewater and distilled water. Tofu wastewater and distilled water volume variation were carried out to obtain optimal plant yields. This study applies a design of the EC control system of tofu wastewater on hydroponic media. The EC of tofu liquid waste is controlled to be suitable for plant growth. To design this system, sensors that have high accuracy are needed. The effect of the temperature on the conductance value obtained from the calibration process, then this value can determine the sensor validation value and the high accuracy of the sensor control system.

In general, domestic tofu industry in the city of Bandar Lampung will directly stream the wastewater to sewers and rivers without going through the waste processing first. The purpose of this study is to utilize the wastewater produced by domestic tofu industries containing high organic pollutants as hydroponic nutrition.

3. Materials and methods

This research was held at the Agricultural Engineering Department of the University of Lampung. The tools used in this study are:

1. The control system component is an Arduino Uno ATmega 328 microcontroller, Arduino Uno shield, EC meter sensor module with a measurement range of 1mS /cm - 20 mS /cm, DS18B20 temperature sensor, Real-Time Clock (RTC) type DS1307, Micro SD card module, 4 channel relay module and 2 channels, 6 single socket, jumper cable, 20 x 4 LCD, laptop, power supply, regulator, transistor, resistor, PCB board, breadboard, EC meter Jenway model 4510.
2. Hydroponic components consist of 2 nutrient storage tanks, waste buckets, water buckets, 6 aquarium pumps, aerators, and pipes.
3. Mustard greens (*Brassica Juncea* L.), AB mix, distilled water, and tofu liquid waste.

3.1. Design of automatic control system

Arduino Uno microcontroller has connected with supporting components such as EC sensor module, temperature sensor, relay, RTC, micro SD card, LCD, power supply, and pump. Then the command program is entered into the Arduino IDE software which has specially designed for automatic EC control. The EC sensor integrated with a microcontroller (Arduino) (Figure 1). Next, the microcontroller is combined with an actuator pump to control the EC value. In the design, the output pin on the EC module connected to the analog pin A0, and the pump connected with a digital pin three on Arduino UNO 328. Figure 2 shows the block diagram design.

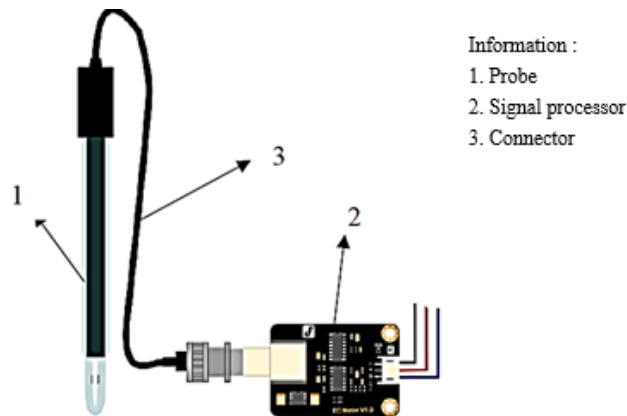

- Information :
1. Probe
 2. Signal processor
 3. Connector

Figure 1. EC sensors are integrated into the microcontroller

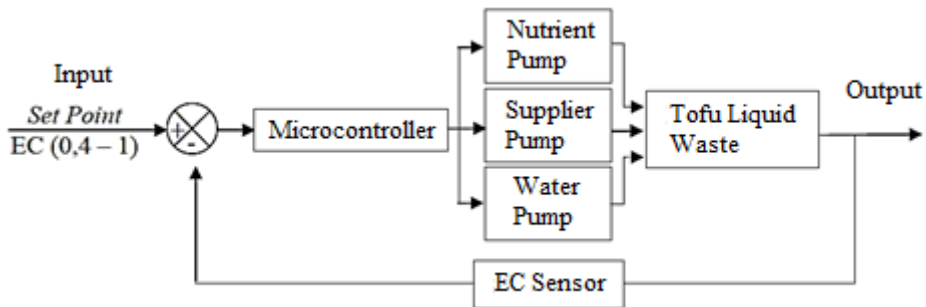

Figure 2. Block Diagram of Control System Design

This study was designed to control EC in susceptible 0.4 mS/cm - 1.0 mS/cm. The EC value is obtained from the sensor placed on the surface of the nutrient solution, then the value is sent to the microcontroller. The microcontroller will execute according to the EC sensor output value by giving an order to the actuator, namely the water pump and tofu liquid waste pump. If the EC value is less than vulnerable (<0.4 mS/cm), the tofu liquid waste pump will light up, but if it is more than vulnerable (> 1.0 mS/cm), the water pump will turn on and enter the nutrient storage tub until the EC value returns to vulnerable.

3.2. Calibration and Validation Procedure of Temperature Sensor

Temperature sensor calibration is calculated by inserting the sensor and calibrator into the distilled water solution which is heated at 40°C. Then the readable output values on the sensor and temperature calibrator are recorded every one minute for one hour. The calibration results are made relationship graphs and regression analysis to obtain the equation functions that will be included in the Arduino IDE software. Validation is calculated to prove the suitability of the sensor output value and the calibrator. The procedure of the validation process is almost the same as calibration, the difference is that the output value from the sensor is the result of the equation function obtained from the regression analysis.

3.3. Calibration and Validation Procedure of EC Sensor

EC sensor calibration is calculated by the dependent EC variables and independent variable relation (temperature, mV, and pH). Initially, the EC sensor and EC kalibrator are inserted into the same AB mix solution. The calibration process was calculated using 4

samples of EC values, which are 1 mS/cm, 2 mS/cm, 3 mS/cm, and 4 mS/cm, then each sample was heated using a hot plate at 28°C, 31°C, 33°C, and 35°C. After that, the sensor output values and the calibrator are recorded then grouped into variable temperature (oC), EC meter, EC sensor (mV), and pH meter. The calibration results are entered into the regression analysis to find the equation values that will be used in the research into the Arduino IDE program. The validation process is almost the same as the calibration stage, but what distinguishes it is the output value of the sensor is in units of mS / cm ready compared to the calibrator. Afterward, both the RMSE test and the temperature sensor and EC sensor are used to see the sensor error value for the calibrator.

$$RMSE = \sqrt{\frac{1}{n} \sum_{i=1}^n (O_i - P_i)^2}$$

- N = amount of data
- O_i = observation data
- P_i = prediction data (Sugiyono, 2007).

3.5. Performance Test

Performance tests are performed to find the value of accuracy, average control time, system response, and system stability. Accuracy values are sought with equations (2.1), (2.2), and (2.3).

$$\text{Inaccuracy} = \frac{\bar{X}}{SP} \times 100 \% \dots\dots\dots (2.1)$$

$$\bar{X} = \frac{\sum_{i=1}^n |SP - NAi|}{n} \dots\dots\dots (2.2)$$

Information :

- \bar{X} = average value
- SP = setting point value
- NA = actual value
- n = amount of data

$$\text{Accuracy} = 100\% - \text{Inaccuracy (in \%)} \dots\dots\dots (2.3)$$

The average control time is observed to find out how fast the device can control the value for the desired vulnerability.

3.6. Hydroponic installation

The EC control system has been made to be able to work continuously in hydroponic media. Two sensors placed in a nutrition storage tank, which are DS18B20 temperature sensor and EC sensor. Each sensor will sense the temperature and EC nutrients. The sensor readings are sent to the microcontroller and then displayed on the LCD and stored on a Micro SD card. The value of the EC reading will be the main factor for giving action from the microcontroller to the relay so that the pump is "active" or "turned off." When the sensor measures the EC value <0.4 mS/cm, the tofu wastewater pump will be activated, if the EC value > 1 mS/cm then the water pump will be activated, then if the EC value is at 0.4-1 mS/cm or in the value range, then the nutrition pump will be active and then sent to the pH control container. The pump on the pH container will send nutrients to the hydroponic installation. After going through the hydroponic installation, the nutrients are fed back into the EC container, and the microcontroller will repeat the process from start to finish.

3.7. Utilization of tofu wastewater

The nutrients used in this study were made from a mixture of fermented tofu wastewater and distillate water with EC value of the nutrient concentration is 0.57 mS/cm. Determination of the concentration of the nutrient solution obtained from trials on Mustard greens plants aged 10 DAP (days after planting). The trial was conducted by preparing three Mustard greens plants and three solution samples with a ratio of tofu and water liquid waste of 1: 5, 1:10, and 1:20 (in liters).

4. Results and discussion

4.1. Characteristic of tofu wastewater

Tofu wastewater is acidic. Therefore, before the waste is processed, it is necessary to check the pH and add a buffer solution to achieve an optimal pH (BPPT, 1997). The initial pH of tofu wastewater is between 4-5, for this purpose fermentation is carried out on the waste in a pre-research trial to increase the pH value to suit the growth requirements of Mustard greens (*Brassica Juncea L.*) plants, which ranges from 5.5 to 6.5.

4.2. Design of automatic control system

The design of this automatic control device (Figure 3) uses a variety of components, such as Arduino Uno microcontroller, EC sensor module, temperature sensor, relay, RTC, micro SD card, LCD, power supply, and pump.

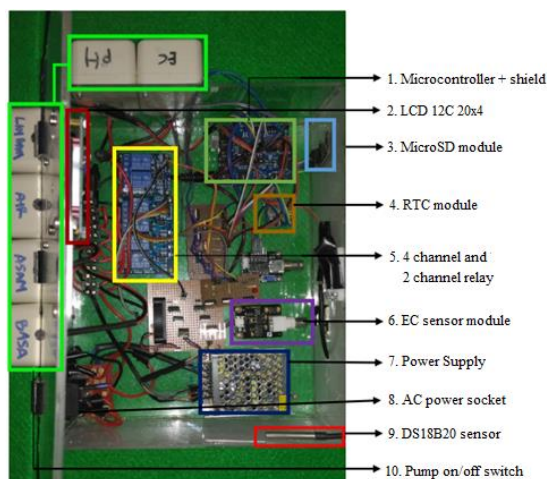

Figure 3. Set of Tools

The microcontroller connected with components that have their respective functions. Arduino Uno microcontroller serves as the brain to process all activities that take place. The Arduino Uno microcontroller can operate at 5V-12V voltage. The function of temperature sensor and EC are to read the temperature and EC value of the solution. RTC is used to record the time (hours, minutes, seconds) of each process that occurs during the process of the microcontroller. The microSD card module stores all data from the process that occurs, both data from sensors and RTC. The function of LCD functions is to display signal output from the sensor and RTC. The power supply has the function to change the AC current from PLN to a 12V voltage DC current as a microcontroller voltage source. Relay has the function as an automatic I/O switch for pumps according to the input signal from sensor readings. The pump has the function as an actuator to drain tofu wastewater according to the command signal from the microcontroller.

4.3. Calibration and Validation of Temperature Sensor

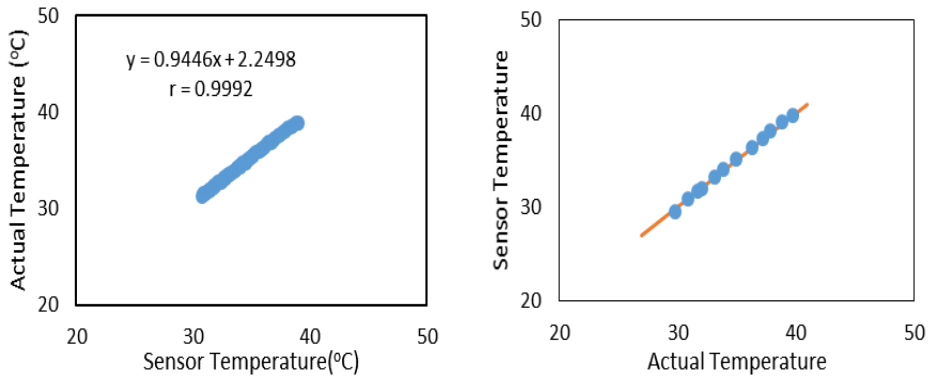

Figure 4. Calibration and validation of temperature sensor

The DS18B20 temperature sensor is a digital sensor so that the output value displayed in Celsius degrees. Temperature calibration result shows a coefficient r-value of 0,9992 which indicates that both relations are strong. From Figure 4, the y equation is used as a temperature sensor correction factor, i.e. :

$T = (0,9446 * \text{temperature sensor}) + 2,2498$. Next step is the validation process.

The temperature sensor validation shows good results because it is in the diagonal line forming a 45 ° angle (Figure 6). The error value of the temperature sensor obtained from the RMSE test is 0,16. The EC sensor calibration process with an EC meter calibrator shows in Figure 5.

4.4. Calibration and Validation of EC Sensor

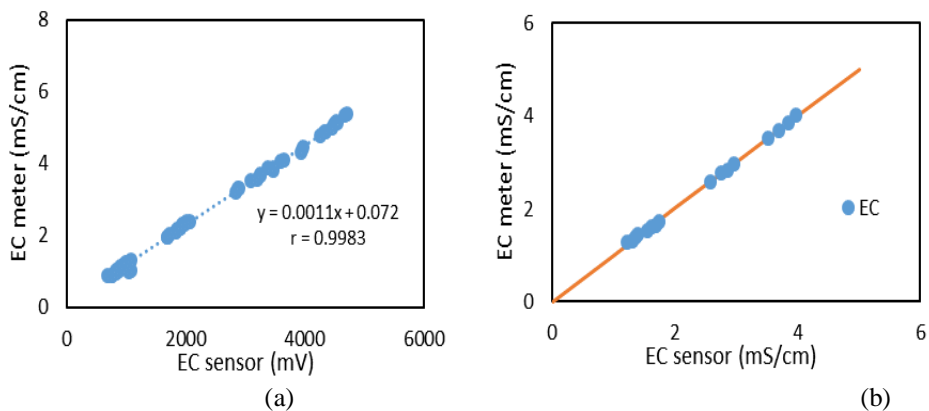

Figure 8. (a) Calibration of EC sensor with calibrator, (b) Validation of EC sensor

From the EC calibration process, obtained that the influential independent variables are temperature and EC (mV) sensor, seen from the r-value coefficient is close to 1, while the pH shows a weak or has no relationship effect because the r-value coefficient is far from 1. Then the temperature and EC variables (mV) are included in the regression analysis, so that the equation is obtained as a correction factor, i.e.

$EC = (0,0015328 * \text{temperature}) + (0,0054178 * \text{mV}) + 0,024268.$

Next step is the validation of EC sensor. Calibration values show in figure 7-9. Figure 9 shows the output value of the sensor is very good, because it is on the diagonal line. The error value of the EC sensor obtained from the RMSE test which is 0,028.

4.5. Hydroponic Installation

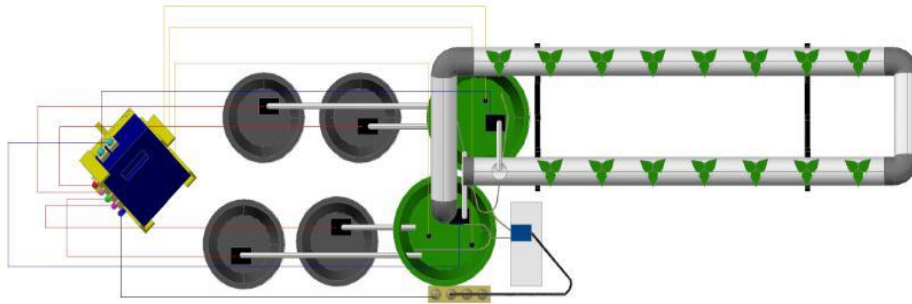

Information:

- | | |
|--------------------------|------------------------------|
| 1. Hydroponic pipe | 6. Microcontroller |
| 2. Nutrition pump cable | 7. Water container |
| 3. Water pump cable | 8. Wastewater container |
| 4. Wastewater pump cable | 9. Nutrition container |
| 5. Aerator | 10. EC sensor cable |
| | 11. Temperature sensor cable |

The value of the EC setting point used in this hydroponic system was set at 0.57 mS/cm. Hydroponic system testing will be turning on the pump when EC conditions are outside the setting point. When passing the upper limit, the water pump lights up to drain the water from the water bucket to the nutrition container for 2 seconds, while the EC value passes the lower limit, the tofu wastewater pump is lit and fed to the nutrition bath for 2 seconds. Water and tofu wastewater flow through an aquarium hose. For 2 seconds the pump turns on, the amount of water or liquid wastewater that comes out is 21 mL and 9 mL respectively. So, during the 48 hours of research running, the total volume of water added was 3 864 mL, and tofu wastewater was 324 mL.

4.6. Utilization of tofu wastewater

Tofu wastewater diluted with distilled water by turning 1:5, 1:10, and 1:20 then poured into the roots of Mustard greens. After two days, the optimal results produced by the plants that are entitled to a ratio of 1:20 and an EC value of 0.57 mS/cm. Greener leaf color and stem size of Mustard greens plants which are larger than the results of growth in mixed variations of 1: 5 and 1:10 are the indicator that in this hydroponic system, the optimal result has been shown by the mixture of 1:20 ratio.

The hydroponic system with a capacity of 200 Mustard greens plants yields 60kg, each kilogram of plants requires 80% of nutrients per day (in liters) because in 1 kilogram of Mustard greens plants need 0.8 liters of nutrients. For this reason, a hydroponic system requires 48 liters of nutrients, with a contribution of 1:20 so in 1 day this system can use 2.4 liters of tofu liquid wastewater.

5. Conclusion

The hydroponic system in this study uses nutrients consisting of a mixture of tofu wastewater and distilled water by controlling the EC value contained in the solution to fit the growth needs of Mustard greens (*Brassica juncea* L.). The best results are shown by Mustard greens plants which were given a mixture of solutions with a 1:20 ratio. By controlling the EC value of 0.57 mS/cm, tofu liquid waste can be used as a nutrient of Mustard greens plants in hydroponic media. The higher the capacity of the hydroponic media used, the higher the use of wastewater from tofu that can be utilized.

6. References

- Asmoro, Y., Suranto, and D. Sutoyo. 2008. The Utilization of Tofu Waste for Petsai (*Brassica Chinensis*) improvement. *Journal of Biotechnology*. 5 (2): 51-55.
- Ernawati, D. 2014. *The Effect of Tofu Liquid Waste on Hydroponic Tomato (*Lycopersicum Esculentum* Mill) Vegetative Growth*. Faculty of Biology. Muhammadiyah University. Semarang.
- Novita, F.D. 2009. The Effect of Frequency and Concentration of Tofu Liquid Waste on Mustard greens Plant Growth. *Thesis*. Department of Biology. Faculty of Science and Technology. Malang State Islamic University. Malang.
- Rosallina, Nur. 2008. The Effect of Concentration and Frequency of Tempe Liquid Waste as Organic Fertilizer for Growth and Tomatoes (*Lycopersicum esculentum* Mill.) Result. *Thesis*. Malang: Biology Department Malang State Islamic University. Poor.
- Rosallina, Nur. 2008. Pengaruh Konsentrasi dan Frekuensi Penyiraman Air Limbah Tempe sebagai Pupuk Organik terhadap Pertumbuhan dan Hasil Tomat (*Lycopersicum esculentum* Mill.). *skripsi*. Malang: Jurusan Biologi Universitas Islam Negeri Malang. Malang.
- Sadzali, I. 2010. The Potential of Tofu Waste as Biogas. *Journal of University of Indonesia for the Nation Series of Health*. Science and Technology 1 (1): 64–65.
- Said, N, I., Indriatmoko, H., Raharjo, N., and Herlambang, A. 1999. Technology of Processing Tofu-Tempe Waste by Anaerobic and Aerobic Biofilter Processes. BPPT. Jakarta.
- Suhardiyanto, H. 2009. Hydroponic Technology for Plant Cultivation. Department of Agricultural Engineering. Faculty of Agricultural Technology IPB. Bogor.
- Telaumbanua, M., B. Purwantana, and L. Sutiarmo. 2014. Design and Construction of Actuators for Micro Climate Control in Greenhouses for Mustard greens (*Brassica rappa* Var. *Parachinensis* L.) Cultivation. *J. Agritech*. 34 (2): 213-222.
- Telaumbanua, M., Anggraini, R., Sasongko, F.I., Fitri, A, Sari, R. F. M., Waluyo, S. 2018. Control System Design for Rat Pest Repellent in the Rice Field Using a Modified ATMega328 Microcontroller Modified with Ultrasonic Sound Wave. *International Journal of Engineering Inventions*. 7(8) : 22-28.
- Untung, O. 2000. *Hidroponik Sayuran System NFT (Nutrient Film Tehknique)*. Penebar Swadaya. Jakarta.



Certificate of Participation

Environmental innovations:

ADVANCES IN ENGINEERING, TECHNOLOGY AND MANAGEMENT

23-27 September, 2019

International Online Conference

Dr. Mareli Telaumbanua
University of Lampung, Indonesia

Chairman

Prof. Aleksander Yudakov

Chairman

Prof. Dean Vucinic

Chairlady

Prof. Valeriya Pinchuk

Scientific Editor

Dr. Andrey Kuzmin