

PAPER NAME

**5171\_Artikel\_Polimesin\_Arif\_Irza\_Aug20  
22.pdf**

AUTHOR

**Irza Sukmana**

WORD COUNT

**4181 Words**

CHARACTER COUNT

**21200 Characters**

PAGE COUNT

**6 Pages**

FILE SIZE

**1.0MB**

SUBMISSION DATE

**Oct 23, 2022 8:08 AM GMT+7**

REPORT DATE

**Oct 23, 2022 8:08 AM GMT+7****● 5% Overall Similarity**

The combined total of all matches, including overlapping sources, for each database.

- 3% Internet database
- 4% Publications database
- Crossref database
- Crossref Posted Content database
- 2% Submitted Works database

**● Excluded from Similarity Report**

- Bibliographic material
- Cited material
- Manually excluded sources

#### Article Info

Received : 2022-06-04 Accepted : 2022-07-04  
Revised : 2022-07-04 Available online : 2022-08-31

## Finite Element Analysis of Magnesium AZ31B Materials for Biodegradable Bone Screw Application

Mahruri Arif Wicaksono, and Irza Sukmana\*

Department of Mechanical Engineering, Faculty of Engineering,  
University of Lampung, Bandar Lampung, 35143, Indonesia

\*Corresponding author: irza.sukmana@gmail.com

### Abstract

The bone implant functions for the load bearing and aims to support the integration of fractured bone. It may increase the strength of the broken bones and also at the same time support bone regeneration and integration. Bone screws are usually attached to the implant plate and bonded to the surface of the fractured bone by screwing the bone screws through the bone structure. In its implementation, a non-degradable implant needs a second operation for the patient to take out the implant. Currently, biomedical researchers are trying to produce bone implants that are degradable or bioresorbable materials. Magnesium (Mg) alloy is a potential biomaterial for bone implants, as Mg is a degradable material. Mg is one of the elements needed and harmless to the human body. This study focuses on finite element analysis (FEA) for the bone screw design of Magnesium alloy that has been well known as a potential candidate for biodegradable bone screw and plate application. The three dimensions (3D) design was done by using Solidworks software, and finite element analysis was performed using ANSYS by calculating the moment, pullout, and force bending received by bone screws. The validation results of the design carried out with several analytical tests before the production of bone screws is proposed. The FEA simulation of bone screws pullout has a total deformation of 0.028 mm and a von Mises stress of 134.25 MPa for a pullout load of 1100 N. The bone screws torsion with a torque of 883 N.mm, the total deformation is 0.988 mm and for bone screws bending with a total deformation of 5.4352 mm has a von Mises stress of 25.706 MPa. AZ31B bone screws, based on the design, are safe and capable of handling the maximum load and deformation during the implantation. In vitro biocompatibility and in vivo studies is needed for further assessment of the design.

### Keywords:

Magnesium AZ31B, Bone Screws, FEA, Pullout, Torsion, Bending.

### Introduction

Bone screws are used to increase strength and resistance to failure in the healing process of bone cracks. Many studies use numerical simulation in combination with optimization algorithms to optimize the design, which reduces the destructive effect and increases the efficiency of the implant. One of the primary purposes of implant components is to strengthen bones and reduce damage using the Taguchi and finite element method to optimize the design and engineering of bone screws [1]. In research conducted previously by Tilton [2] mechanical testing and

simulation of elements to increase the bending strength of tibia bone screws, titanium, and stainless steel, which are still often used but have the disadvantage of doing a second operation.

Magnesium is one of the potential candidate materials for biodegradable implant. The mechanical properties of magnesium and alloys have a low density ( $1.74-2.0 \text{ g/cm}^3$ ) and a modulus of elasticity (41-45GPa). Finite Element Analysis (FEA) is one of the techniques that has been used to test and validate the desired characteristics for biodegradable Mg-based support threads. The characteristics of interest include the maximum tensile resistance possible to hold the bone segment firmly, the torsional ability to tighten [3].

Approaching the bone modulus, the biodegradability of magnesium and its alloys in the human body avoids a second operation for temporary implants [4]. The mechanical properties of AZ31B magnesium material will decrease because it's degradation process. Therefore the degradation rate of the magnesium implant should fit with the bone fracture recovery. The percentage of elements in magnesium alloys greatly affects the mechanical properties and biocompatibility magnesium [5]. The design of the bone screws refers to the Depuy Synthes Instruments and implants catalog, with specifications, sizes, and materials [6].

The biomaterials are not only used in the body but something that helps or is in contact with the human body aims to cure a malfunction of the body in humans such as cracked bone healing aids (bone screws-plates), stroke disease therapy tools [7], prosthetic models compliant anklefoot [8] and ankle foot orthosis (AFO) is an orthopedic device that is attached to the foot to improve the structure of the foot and help the user to return to normal running [9].

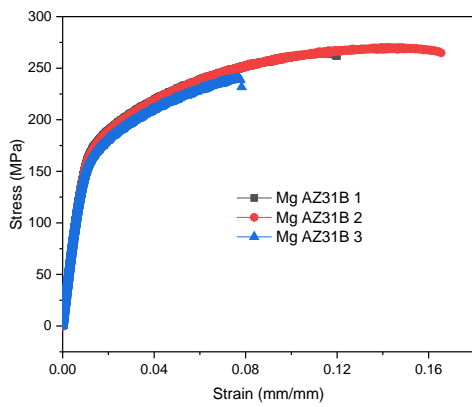
Optimizations is done to get an effective bone screws design according to the application. The design is carried out from the specific thread, bone screws length, bone screws diameters and bone screws material. This research is conducted to design and analyze with the finite element analysis method on bone screws based on material Magnesium AZ31B. Study of the corrosion and biodegradation study is not included in this paper.

### 1.1 Materials and Methods

The research was conducted in March - August 2022, the design process and simulation of bone screws were carried out at the Structural Mechanics Laboratory of the Department of Mechanical Engineering, the University of Lampung under the catalog of Depuy Synthes Instruments and implants, then using magnesium AZ31B material in the form of a rigid cylinder with an initial diameter of 10 mm and a length of 130 mm. After preparing the tools and materials first carry out a 3-dimensional design process using Solidworks then the FEA analysis process is carried out. The analysis process is carried out using Ansys software with procedures as follow: input data engineering, import geometry, static structural, meshing, boundary conditions, pullout bone screw, torsion and bending testing, to get FEA results in the form of total deformation and von Mises stress.

### 2 Materials

Magnesium material is a light metal with a density of about  $1.77 \text{ g/cm}^3$ . The use of the material in the FEA simulation of cortical bones is assumed to be normal cortical bones with a density of  $1.61 \text{ g/cm}^3 - 1.77 \text{ g/cm}^3$  [10], and the modelling is for material elastic-plastic. Mg-based biomaterials have more excellent toughness than ceramic and polymer-based biomaterials because their elastic modulus is about 45 GPa and The tensile test graph and mechanical properties of magnesium material AZ31B with the cortical bone are as follows in fig. 1.



**Fig. 1** Tensile test graph of stress vs strain

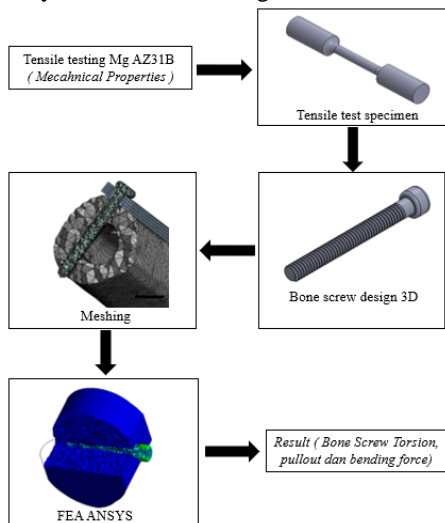
The modulus of elasticity of magnesium metal material has characteristics that are almost close to the nature of the modulus of elasticity of human bones, which is about 7-25 GPa [11] while bone screws are made of Ti-6Al-4V material with modulus young and poisson ratios of 113 GPa and 0.3 [12]. This study used magnesium material AZ31B extrude rod with a diameter of 10 mm with a length of 130 mm. Magnesium AZ31B was purchased at the manufacturing company Xi'an Yuechen Metal Products Co., Ltd, Using production technology in accordance with international standards and product specifications SGS BV model number AZ31B-H24 specifically for production using ASTM B107/B107M-13 standards.

**Table 1.** Mechanical properties Mg AZ31B and cortical bone

No	Materials	Parameter	
1	Mg AZ31B	Yield Strength	153,15 MPa
		Modulus young	44,28 GPa
		Density	1,77 g/cm <sup>3</sup>
		Poisson Ratio	0,35
		Ultimate	258,44 MPa
2	Cortical bone	Modulus Young	20 GPa
		Density	1,7 g/cm <sup>3</sup>
		Poisson Ratio	0,25

### 2.1 Analysis Methods

Development and production in bone screws engineering where this research is expected to be in accordance with standard procedures and can be commercialized. The method used to analyze the Ansys software is like fig. 2.



**Fig. 2.** Flowchart of simulation methods

In the method carried out the analysis process, conduct tensile testing (ASTM B557) to determine the ultimate tensile strength

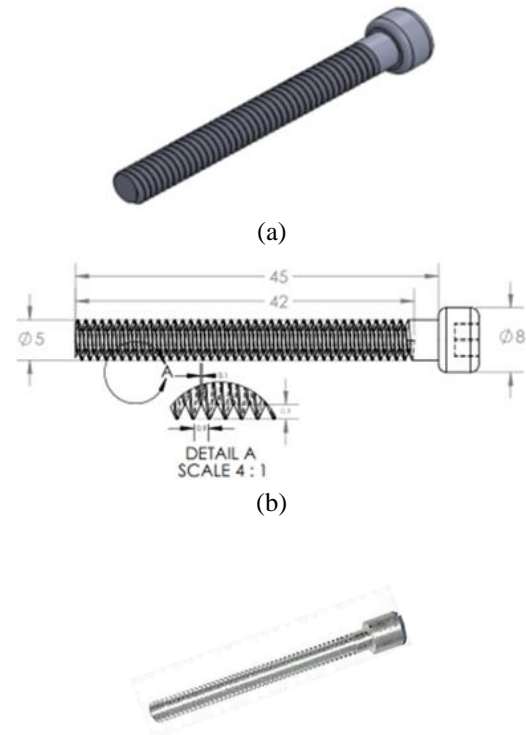
and modulus young, enter engineering data from the results of tensile testing of magnesium material AZ31B then simulate FEA static structural bone screws torsion, bone screws pullout and bone screws bending then carry out mesh convergence. In the analysis with FEA, the results of total deformation, von Mises stress and linearized von Mises stress were obtained.

### 3 Results and Discussion.

The results and discussions in the research that has been carried out are through several stages such as CAD design (Solidworks), input engineering data (ultimate tensile strength, Poisson ratio, density), determination of meshing, boundary conditions (bone screws torsion, bone screws pullout, bone screws bending testing force), solve and result (total deformation and von Mises stress) are as follows:

#### 3.1 Geometry CAD

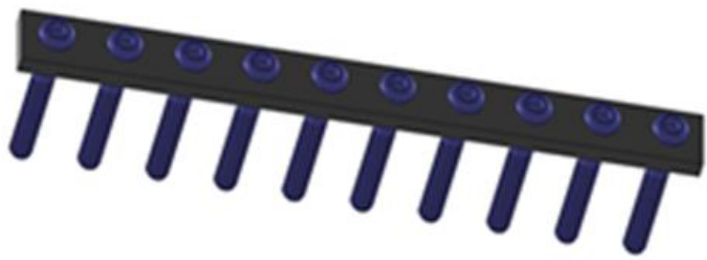
Bone screws with a diameter of 5 mm, length of 40 mm, and pitch of 1 mm is the geometric dimensions of the cortical bone screws to be used. The bone screws in previous studies were modified to provide design factors such as pitch length, primary diameter, thread profile, and geometry variations. In Biswas's research [12], 84 FE models were developed with seven pitch lengths (1, 1.5, 2, 2.5, 3, 3.5 and 4 mm). Tetteh and McCullough [13] focused on the thread profile and thread shape effect on the transfer of stress distribution in the bone using finite element analysis. It was concluded that bone screws with a trapezoidal threaded shape could transfer higher stress to surface contact in cortical bones. Zain's research [14] studied the orthopedic stress distribution of screws implants in trabecular bones, which are very porous with biological tissues. In this study, the shape of the screws the profile of the thread, and its details are presented in fig. 3.



**Fig. 3.** (a) 3D geometry of bone screws, (b) Geometry of 2-D bone screws, (c) Manufacturing of bone screws

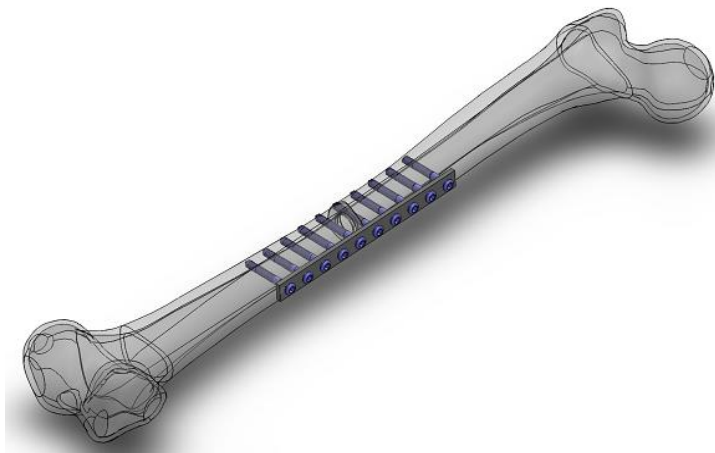
The geometric dimensions of bones are adjusted to human bones in general. For the step to be carried out, first make a hole with a hole diameter of 5 mm produced by drilling in the middle

part of the bone prepared in so that the upper and lower parts of the bone can be drilled in the same direction. The process of combining the bone screws and bone plates with being attached can be described in fig. 4.

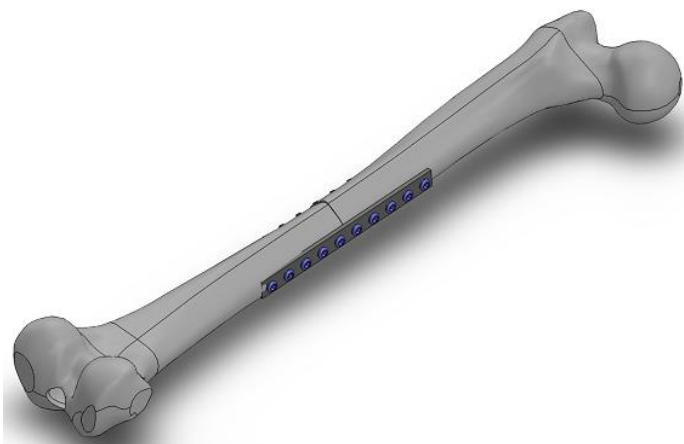


**Fig. 4.** Assembly screws and bone plates

While in the geometry assembly of bone screws, bone plates, and cortical bones, there will be contact with surfaces such as plate contact with cortical bone, bone plate with bone screws, and bone screws with the cortical bone. For bone plate assembly, bone screws and cortical bone, as shown in fig. 5.



(a)



(b)

**Fig. 5.** Assembly of bone screws, (a) bone plates, and (b) cortical bones

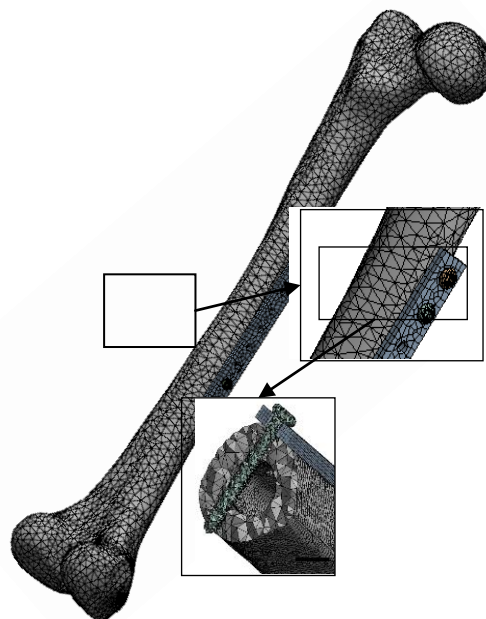
### 3.2 Meshing

Meshing is performed to divide the model parts into small element parts. Meshing helps determine the distribution of a given stress. There are several types of elements such as hexahedron (simple components), tetrahedron and polyhedron (complex geometry details). The type of mesh used uses tetrahedron elements because it is a type of meshing that is entirely accurate for fairly complex geometry details. In the study, there were three parts, namely bone screws, bone screws assembly, and bone plates with cortical bones, as shown in table 2 and fig. 6.

**Table 2.** Mesh Convergence

Simulasi FEA	Element Size (mm)	Element	Total Deformasi (mm)	Von Mises Stress (MPa)
Bone Screws Torsion	1.5	230.247	0,988	16.984
Bone Screws Pullout	1.25	401.119	0,028	134,25
Bone Screws Bending	1.5	230.247	5,4352	25.706

Assembly element meshing (Fig. 6)



**Fig. 6.** Assembly element meshing

For meshing, a 4-noded tetrahedron element is used and convergence analysis is performed by resetting the element size until an error of less than 3% from eksperiment [15]. Meanwhile, the research conducted by Mau et al. [16] carried out meshing with tetrahedral elements as many as 140298 elements with an element size of 0.8 mm with almost the same design dimensions geometry.

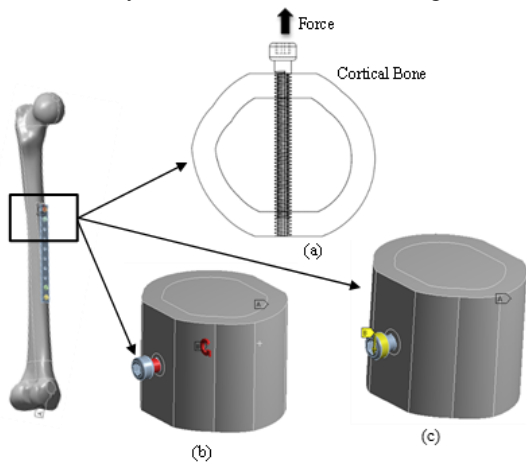
### 3.3 Boundary Conditions

Boundary conditions were performed on FEA simulations of bone screws to determine the limit conditions to be accepted by the predetermined bone screws design. Contact surface used "frictional" because the bone screw will cause friction between the bone plate with bone screw, bone screw with cortical bone then bone screw receive tensile and bending loads so that it will cause widening of the bone screw with bone screw holes. (gap open/close, sliding and friction). Bboundary conditions are performed on bone screws with torsion conditions, pullout bone screws and bending bone screws. In the boundary conditions of bone screws pullout, FEA simulations use variations in the load that is assumed to be the

weight body of humans of various ages, namely 700 N (71,38 kg), 800 N (81.57 kg), 900 N (91.77 kg), 1000 N (101.97 kg) and 1100 N (112.16 kg) [17]. With FEA simulation, it can find out the location of the maximum stress and deformation on the bone screws. In the FEA simulation, boundary conditions have been carried out with fixed support on the bone while the force is given

in the direction of the bone screws axis with tensile load conditions. While the Boundary conditions is carried out with bone assembly and screws with engineering data according to the actual condition of both bone material and Mg AZ31B material.

The torsion FEA simulation test was given moments of 883 N.mm [18], 706.9 N.mm, 651.1 N.mm, 628.9 N.mm [19] clockwise and in bone screws bending boundary. fixed condition support was given to the bone then loading by displacement against the axis perpendicular to the bone screws. In the FEA simulation research that has been carried out, namely the x-axis: 5 mm, the y-axis: free and the z-axis: free. There is a series in carrying out boundary conditions, which is like fig. 7.

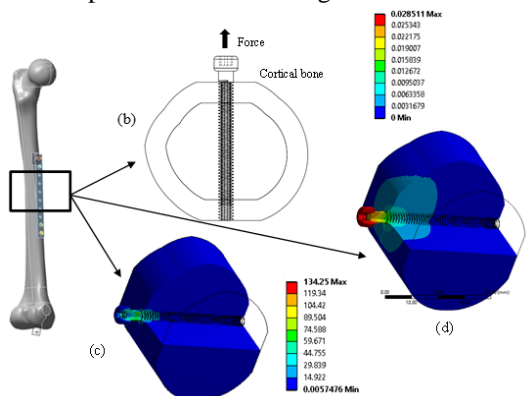


**Fig. 7.** Boundary conditions assembly bone plate screws, (a) Bone screws pullout, (b) Bone screws torsion, (c) Bone screws bending

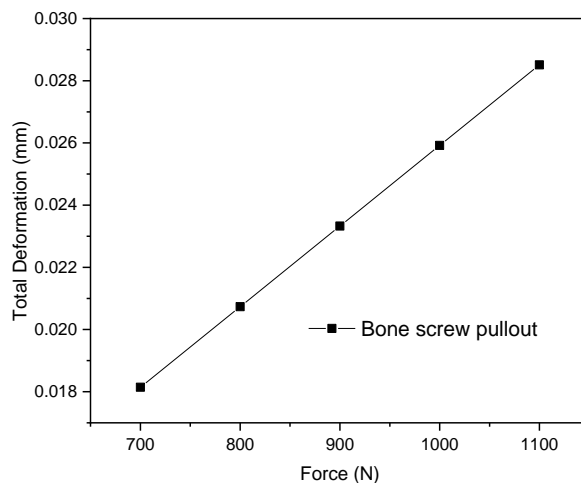
### 3.4 Bone Screws Pullout

Bone screws pullout testing is a test with FEA simulation to determine the deformation and maximum load that a screw can receive on a load in the direction of the bone screws. Then after FEA simulations were carried out on bone screws pullouts total deformation of 0.028 mm and von Mises stress of 134.25 MPa against pullout loads of 1100 N in FEA simulations, In the test the greater the load given by pullouts, the greater the deformation produced.

The research conducted by Keshtiban [20] was obtained with a cortical screw FEA von Mises stress of 449 MPa and total deformation of 0.0624 mm with Ti6Al4V material. In FEA simulations the greater the pullout tensile load, the greater the deformation the bone screws produce against the cortical bone. The pullout load on the normal cortical bone is 1450 N [21] while at a load of 1100 N with a total deformation of 0.2 mm it is made of stainless steel [22]. The bone screws pullout image is like fig. 8. The bone screws pullout chart is like fig. 9.

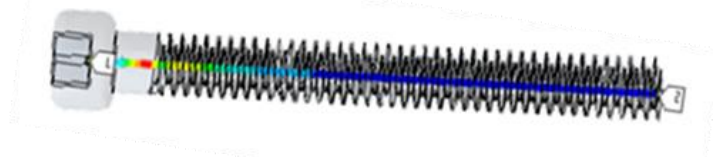


**Fig. 8.** (a). Cortical bone (b). Pullout schematic, (c) Von Mises stress, (d) Total deformation

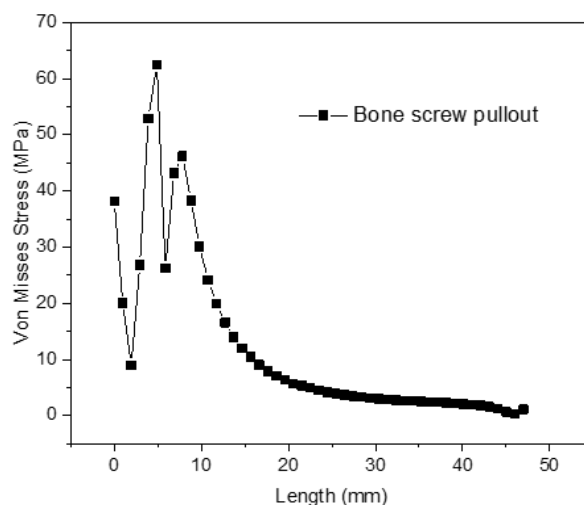


**Fig. 9.** Graph of total deformation to force variations

In addition, to know the load given to the total deformation and von Mises stress obtained, it is also necessary to know the stress distribution of bone screws in pullout conditions. This condition is carried out in order to be able to find out the stress distribution that occurs on the length of the bone screws. The linearized von Mises stress condition against the length of the screws is as fig. 10-11.



**Fig. 10.** Linearized equivalent stress bone screws pullout



**Fig. 11.** Linearized von Mises stress bone screws pullout graph

A graph of stress distribution over bone screws length was then obtained (fig. 11). The stress distribution that occurs, namely on the screws head of 2.9376 mm, the stress occurs at 26,852 MPa then on the screws rod 4.896 mm experiences maximum stress of 62,538 MPa, then the farther from the pullout condition, the stress drops more and lower at a distance of 46.023 mm has the lowest stress of 0.26643 MPa.

### 3.5 Bone Screws Torsion

After the boundary conditions are carried out, the results of the FEA simulation of total deformation will be obtained. FEA moment simulation testing is carried out to determine the maximum moment given by the screws until bone damage occurs. The research of Moldovan and Bataga [23] determined the optimal

torque, refers to the graph of the torque variation curve such as threshold torque, peak clamping torque, and peak failure torque. There appears to be damage to the bone resulting at the moment given. The chart is like fig. 12-13.

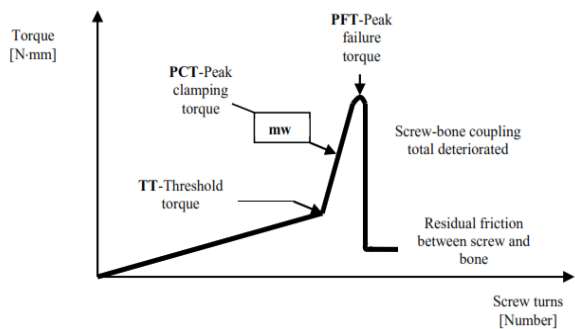


Fig. 12. Variations in the torque conditions [23]

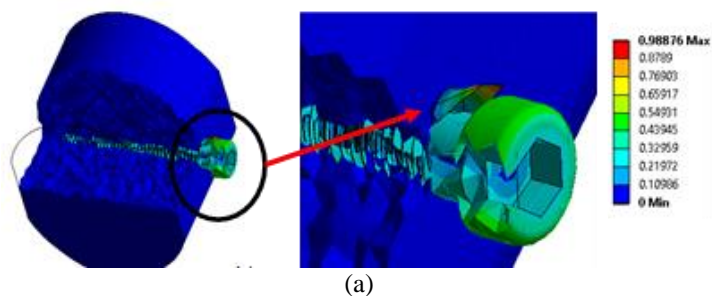


Fig. 13. Total deformation (a). FEA, (b). Experimental [23]

### 3.6 Bone Screws Bending

In bone screws bending testing aims to determine the maximum load that the screws assembly and bone can receive with a longitudinal loading perpendicular to the bone screws. From the boundary conditions given, then a FEA simulation is carried out, it will find out the deformation of the stress. Then bone screws bending is given a conditions on the path along the screws to determine the stress distribution to the length of the bone screws. The results of the FEA simulation are like fig. 14 as follows.

In a FEA simulation, the bone screws deform when receiving the maximum load. The part of the bone screws that receives tension in the bone screws display is known to be linearized von Mises stress. The graph of the stress that occurs along the bone screws is in fig. 16. The results of linearized equivalent stress bone screws bending are as fig. 15.

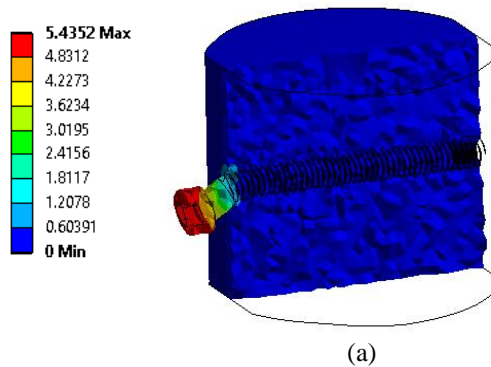


Fig. 14. (a). Total deformation, (b). Von Mises stress

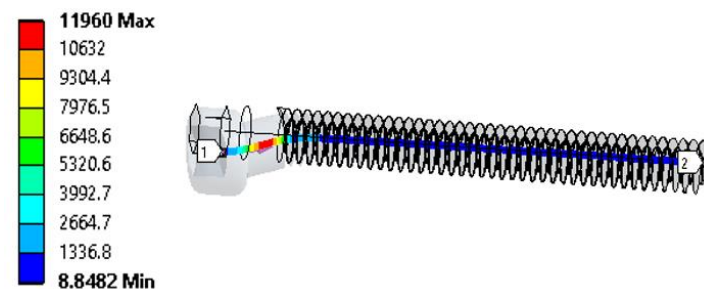


Fig. 15 Linearized equivalent stress bone screws bending

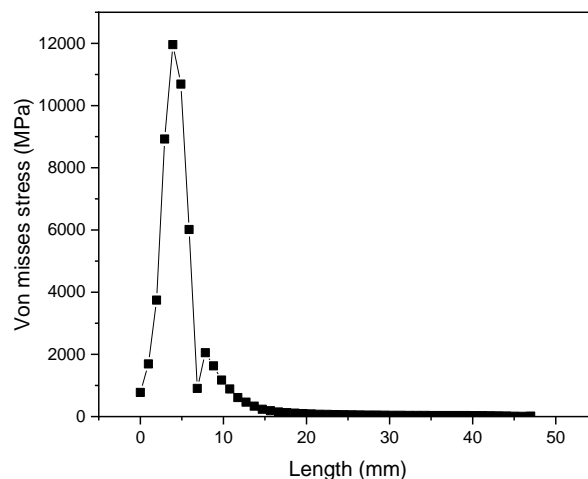


Fig. 16. Stress graph along with bone screws

From a linearized graph of von Mises stress along with bone screws that receive the load. The stress distribution that occurs, namely in the screws head of 2.9376 mm, the stress occurs at 8924.8 MPa (8.9248 GPa) then in the screws rod 4.896 mm it experiences maximum stress of 11960 MPa (11,960 GPa), The farther from the bending condition, the stress drops further at a distance of 46,023 mm and has the lowest stress of 8.8482 MPa.

#### 4 Conclusions

This research design and analysis of bone screw, simulation results were obtained using the finite element analysis (FEA) method in the form of pullout bone screw, torsion bone screw and bending bone screw have been done. It can be concluded that in the bone screw test that with the design of the screw that at a load of 1100 N the pullout deformation only occurs at 0.028 mm then the torsion bone screw at 883 N.mm is damaged in the bone screw hole and is declared unsafe or has already been damaged.

#### Acknowledgement

This is to acknowledge the support of Kemendikbudristek under the grant scheme Hibah Penelitian Tesis Magister (PTM) contract no.: 114/E5/PG.02.00.PT/2022.

#### References

- [1] Stahel, P.F., Alfonso, N.A., Henderson, C., Baldini, T. Introducing The “ Bone-Screw-Fastener ” For Improved Screw Fixation In Orthopedic Surgery: A Revolutionary Paradigm Shift, *Patient Saf Surg.* 11 1–8. Doi:10.1186/S13037-017-0121-5. November 2017.
- [2] Tilton, M., Armstrong, A.D, Wee, H., Hast, M.W., Manogharan, G., Lewis Gs. Finite element-predicted effects of screw configuration in proximal humerus fracture fixation. *Journal of Biomechanical Engineering [Internet].* 2020 [cited 2021 Mar 25];142. Available from: <https://doi.org/10.1115/1.4045907>. March 2021.
- [3] Chandra, G., & Pandey, A. (2021). Design and analysis of biodegradable buttress threaded screws for fracture fixation in orthopedics: a finite element analysis. *Biomedical Physics & Engineering Express*, 7(4), 045010.
- [4] Wang, S., Wang, D., Lin, Y., Li, X. Biomechanical Analysis Of Femoral Fixation With A New Compression Plate Using Finite Element Method During Stair Climbing. *Key Engineering Materials Submitted: 2015-11-24 Issn: 1662-9795, Vol. 693, Pp 297-305 Accepted: 2015-12-31.* Doi:10.4028/Www.Scientific.Net/Kem.693.297 Online: 2016-05-20 2016 Trans Tech Publications, Switzerland. 2016.
- [5] Ibrahim, F., & Sukmana, I. (2021). Application of magnesium alloys in orthopedic implant. *Jurnal Polimesin*, 19(2), 182-187.
- [6] Catalog Depuy Synthes Instrument And Implants. 2011 <http://synthes.com> accessed on Tuesday, June 15, 2021 at 16.00 WIB.
- [7] Emzain, Z. F., Huang, S. C., Yang, Y. S., & Qosim, N. Design and Analysis of a Dynamic Splint Based on Pulley Rotation for Post-Stroke Finger Extension Rehabilitation Device. *Jurnal Rekayasa Mesin*, 11(3), 477-485. 2020.
- [8] Emzain, Z. F., Amrullah, U. S., & Mufarrih, A. M. (2020). Analisis elemen hingga untuk siklus berjalan pada model prostetik lentur pergelangan kaki. *Jurnal Polimesin*, 18(2), 91-98.
- [9] Suhendrianto, S., Zuhri, S., Tarigan, H. A. N., & Asbar, A. (2021). Konsep desain dan perbaikan produk Ankle Foot Orthosis menggunakan metode kansei engineering. *Jurnal Polimesin*, 19(2), 140-146.
- [10] Lee, E. S., Goh, T. S., Heo, J. Y., Kim, Y. J., Lee, S. E., Kim, Y. H., & Lee, C. S. Experimental evaluation of screw pullout force and adjacent bone damage according to pedicle screw design parameters in normal and osteoporotic bones. *Applied Sciences*, 9(3), 586. 2019.
- [11] Witte, F. The history of biodegradable magnesium implants: A review. *Acta Biomater.* 6, 1680–1692. 2008.
- [12] Biswas, J. K., Sahu, T. P., Rana, M., Roy, S., Karmakar, S.K., Majumder, S., & Roychowdhury, A. Design factors of lumbar pedicle screws under bending load: A finite element analysis. *Biocybernetics and Biomedical Engineering.* doi:10.1016/j.bbe.2018.10.003. January 2019.
- [13] Tetteh, E., Mccullough, M.B. Impact Of Screw Thread Shape On Stress Transfer In Bone: A Finite Element Study, *Computer Methods In Biomechanics And Biomedical Engineering*, Pp. 1-6, 2020.
- [14] Zain, N., Daud, R., Aziz, N., Ahmad, K., Ismail, A., Izzawati, B. Stress Analysis Prediction On Screw Orthopedic Implant In Trabecular Bone, *Materials Today: Proceedings*, Vol. 16, Pp. 1838-1845, 2019.
- [15] Wang, W., Baran, G.R., Garg, H., Betz, R.R., Moumene, M., Cahill, P.J. The benefits of cement augmentation of pedicle screw fixation are increased in osteoporotic bone: a finite element analysis. *Spine Deform*;2(4):248–59. 2017.
- [16] Mau, J. R., Hawkins, K. M., Woo, S. L. Y., Kim, K. E., & Mccullough, M. B. Design of a new magnesium-based anterior cruciate ligament interference screw using finite element analysis. *Journal of Orthopaedic Translation*, 20, 25-30. 2020.
- [17] Tejszewska, D., Świtoński, E., & Gzik, M . (2011) Biomechanics of the human locomotor system. Publishing house.
- [18] Wilkie, J., Docherty, P. D., & Moller, K. Stripping Torque Model for Bone Screws. 11th IFAC Symposium on Biological and Medical Systems BMS 2021 Ghent, Belgium, 19-22 September 2021. Volume 54, Issue 15, 2021, Pages 442-447. 2021.
- [19] Silva, A. S., Mendes, J. M., Araujo, T., Aroso, C., & Barreiros, P. Comparison of Mechanical Resistance to Maximal Torsion Stress in Original and Nonoriginal or Compatible Prosthetic Implant Screws: An In Vitro Study. *International Journal of Dentistry*, 2021.
- [20] Keshtiban, P.M., Regbat, M., & Keshtiban, M.M. An investigation of tensile strength of Ti6Al4V titanium screw inside femur bone using finite element and experimental tests. *Journal of Computational Applied Mechanics*, 51(1), 91-97. 2020.
- [21] Xu, M., Yang, J., Lieberman, I. H., & Haddas, R. Finite element method-based study of pedicle screw–bone connection in pullout test and physiological spinal loads. *Medical engineering & physics*, 67, 11-21. 2019.
- [22] Lee, E. S., Goh, T. S., Heo, J. Y., Kim, Y. J., Lee, S. E., Kim, Y. H., & Lee, C. S. Experimental evaluation of screw pullout force and adjacent bone damage according to pedicle screw design parameters in normal and osteoporotic bones. *Applied Sciences*, 9(3), 586. 2019.
- [23] Moldovan, F., & Bataga, T. Torque Control during Bone Insertion of Cortical Screws. *Procedia Manufacturing*, 46, 484-490. 2020.

## ● 5% Overall Similarity

Top sources found in the following databases:

- 3% Internet database
- Crossref database
- 2% Submitted Works database
- 4% Publications database
- Crossref Posted Content database

### TOP SOURCES

The sources with the highest number of matches within the submission. Overlapping sources will not be displayed.

1	<b>pdftutorial.net</b> Internet	<1%
2	<b>IFMBE Proceedings, 2010.</b> Crossref	<1%
3	<b>arpnjournals.org</b> Internet	<1%
4	<b>Coventry University on 2022-08-13</b> Submitted works	<1%
5	<b>Fikri Akbar Mubarok, Harsiwi Candra Sari, Mohammad Firdaus, Winda ...</b> Crossref	<1%
6	<b>e-tarjome.com</b> Internet	<1%
7	<b>link.springer.com</b> Internet	<1%
8	<b>Jayanta Kumar Biswas, Tikeshwar Prasad Sahu, Masud Rana, Sandipa...</b> Crossref	<1%



9	<b>scholarworks.utep.edu</b>	Internet	<1%
10	<b>hindawi.com</b>	Internet	<1%
11	<b>opus.hs-furtwangen.de</b>	Internet	<1%
12	<b>Huang, Heng-Li, Kuo-Chih Su, Lih-Jyh Fuh, Michael Y.C. Chen, Jay Wu, ...</b>	Crossref	<1%
13	<b>Olga Chabarova. "Kaulinio audinio patologijos poveikio žmogaus stubu..."</b>	Crossref	<1%
14	<b>hrcak.srce.hr</b>	Internet	<1%
15	<b>scindeks-clanci.ceon.rs</b>	Internet	<1%
16	<b>scientific.net</b>	Internet	<1%
17	<b>Chi-leung Hui, Jinli Piao, M. S. Wong, ZhiYong Chen. "Study of Textile F..."</b>	Crossref	<1%