

PAPER • OPEN ACCESS

Partial discharge type detection and identification based on its sources

To cite this article: R W Putra *et al* 2021 *IOP Conf. Ser.: Mater. Sci. Eng.* **1173** 012022

View the [article online](#) for updates and enhancements.

You may also like

- [Sigma-Delta ADC Topology Implementation Based on Partial Discharge Detection using Rogowski Coil Sensor](#)
M N K H Rohani, M Isa, M Syahril et al.
- [Design and Implementation of a Multi-sensor PD Online Monitoring System in GIS](#)
X L Hu, J Yong, B Yang et al.
- [Location Technique based on Multiple Partial Discharge Signal in 11kV Underground Power Cable using EMTP-ATP Software](#)
M I A M Halim, N K H Rohani, N Rosle et al.

Partial discharge type detection and identification based on its sources

R W Putra¹, H H Sinaga^{1*}, N Purwasih¹, D Permata¹, Y Yuniati¹, and H B H Sitorus²

¹ Department of Electrical Engineering, Universitas Lampung, Jalan Prof. Soemantri Brojonegoro No.1, Bandar Lampung 35145, Indonesia

² Department of Electrical Engineering, Universitas Pembangunan Nasional Veteran Jakarta, Jalan RS Fatmawati, Cilandak, Kota Jakarta Selatan, DKI Jakarta 12450, Indonesia

*Email: herman.h.sinaga@eng.unila.ac.id

Abstract. Partial discharge (PD) is a symptom of initial damage to high voltage equipment insulators which if left for a long period will cause total damage to high voltage equipment. This study aims to detect and identify the type of PD based on the source of its discharge so that it can be useful in terms of monitoring and maintenance of high voltage equipment. In this research, the Hilbert fractal antenna sensor is used in the detection process of surface, cavity, and corona PD with different input voltage variables that successfully produce a total of 600 PD signal data on the oscilloscope. To reduce noise on the PD signal, the denoising process is done by utilizing the sym4 wavelet feature found in the MATLAB software. The denoising process generates new data so that the research data becomes 600 original PD signal data and 600 denoising PD signal data. With a statistical approach, all PD signal data is extracted successfully into the mean, skewness, kurtosis, and standard deviation parameters which are useful as input for the PD type identification process. From each of the PD signal statistical data, 450 data are used in the training data process and 150 data are used in the data testing process. The PD type identification process is performed using a back propagation neural network with a mean square error (MSE) level of 0.01. The identification results show that back propagation neural networks are able to identify PD types based on statistical input accurately. In addition, the denoising process also affects the accuracy of the identification results of the PD type that is 95.33% for the original discharge signal to 97.33% for the denoising signal.

Keywords: partial discharge (PD), PD identification, Hilbert fractal antenna, back propagation

1. Introduction

Partial Discharge (PD) is a phenomenon of discharge which results in the deterioration of insulating material on high voltage equipment. This situation sometimes occurs in power transformers due to the electric field pressure that exceeds the threshold value of the insulator (inception voltage). If the PD event is left for a long period of time, there will be a decrease in the quality of the insulating material or even cause a breakdown event. Therefore, the detection and identification of PD signal characteristics is very important so that the risk of damage to high voltage equipment can be avoided [1].



Content from this work may be used under the terms of the [Creative Commons Attribution 3.0 licence](https://creativecommons.org/licenses/by/3.0/). Any further distribution of this work must maintain attribution to the author(s) and the title of the work, journal citation and DOI.

In general, PD detection methods can be grouped into two types, namely conventional and non-conventional. The conventional method is a PD detection method that refers to the IEC 60270 standard, while the non-conventional method is a method that does not follow the standard rules according to IEC 60270. Basically, this method can be divided into several types namely the Acoustic, Optical, and Ultra High Frequency methods (UHF) [2].

Some previous PD detection studies have actually been carried out. Researchers [3,4] have successfully analyzed PD from detection results based on magnitude, pattern, and time of occurrence of PD using the IEC 60270 method. PD detection using the optical fiber method has also been carried out by [5]. In this study, a peak-plate arrangement was used to produce PD sources, then conventional methods and fiber optic methods were used to detect and find out the location of PD. In addition, PD detection studies using acoustic methods have also been successfully carried out by other researchers [6-8] who are known to be very effective acoustic methods when used in liquid insulators such as transformer oil.

2. PD detection and identification

2.1. Partial Discharge type

Partial Discharge (PD) usually can be grouped into three types, namely discharge that occurs on the surface (surface discharge), cavities (void discharge), and corona (corona discharge). Surface discharge is a phenomenon of discharge that occurs on the surface of insulating material. Void discharge is a discharge phenomenon in the inner cavity of the insulator. Air cavities can be produced due to production defects in the insulating material. Corona discharge is an eruption that occurs due to the acceleration of ionization events under the pressure of an electric field on sharp metal material in the open air.

2.2. Hilbert fractal antenna for PD detection

In PD detection, a sensor that can work detects electromagnetic waves at high frequencies is required. One of the sensors that meet the criteria is the Hilbert fractal antenna sensor [9]. Based on research done by [9], this sensor is rated effective for detecting electromagnetic waves which work at a frequency range of 300 MHz to 1 GHz [9]. This frequency range is at the UHF frequency range [1, 6, 10]. In addition to this research, it was proposed to use the Hilbert fractal 4th order antenna sensor because the size can be made very small and have a large spectrum frequency bandwidth [11].

In accordance with its name, the Hilbert fractal antenna sensor is a micro-strip sensor type with continuous fractal curve consisting of 1st order up to 4th order. The larger the fractals order, the greater the gain is generated on the sensor [12]. The fractal order can be seen in the Figure 1.

In its use, the performance of this sensor is influenced by several factors namely such as surface area (L), segment Length (d), number of segments (S), and curve order (n). In general, these parameters can be calculated using some of the following equations [12].

$$d = \frac{L}{2^{n-1}} \quad (1)$$

$$S = (2^{2n} - 1)d \quad (2)$$

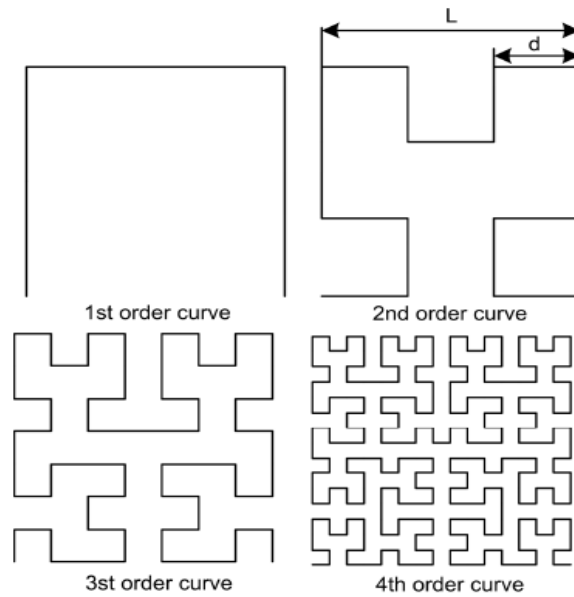


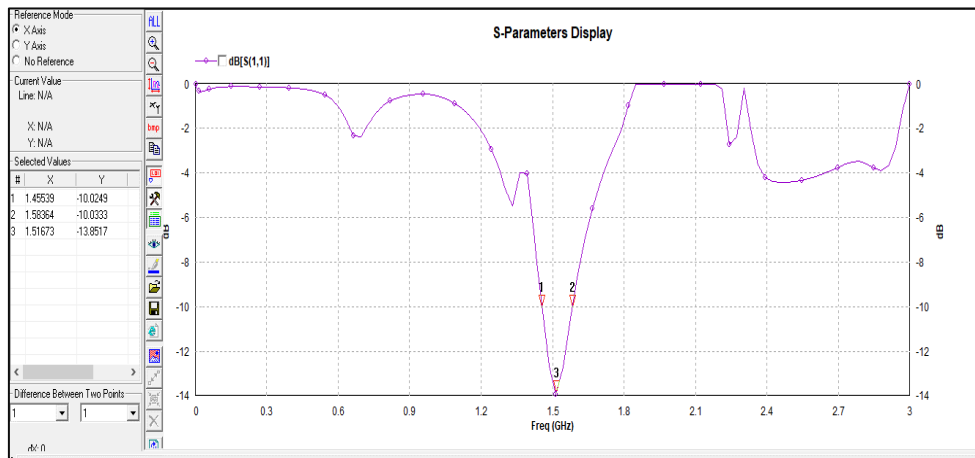
Figure 1. Hilbert Fractal Curve 1st up to 4th order [12].

The shape of the Hilbert fractal antenna sensor used in this study can be seen in Figure 2 below.

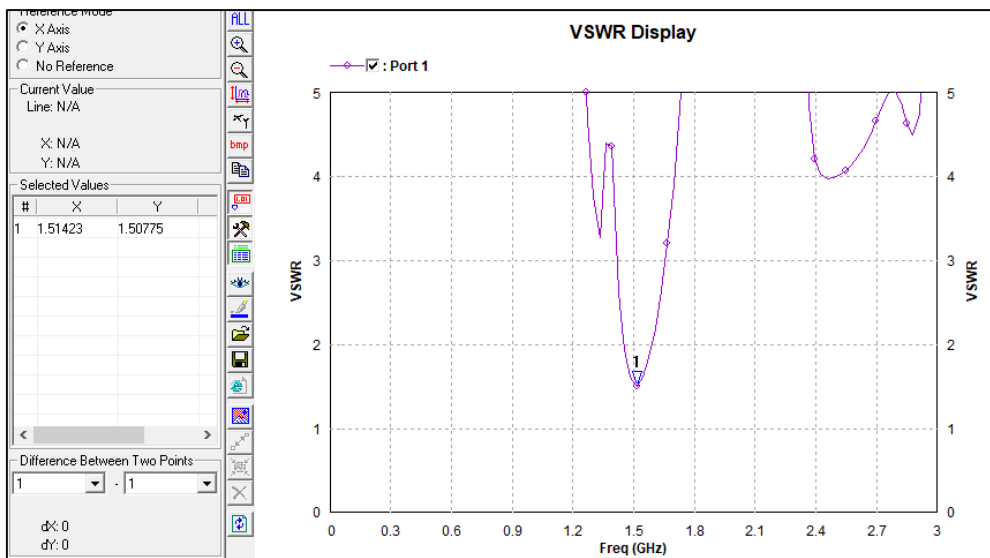


Figure 2. Microstrip Hilbert fractal 4th order antenna.

In designing and manufacturing Hilbert sensor, IE3D software is used to determine S-parameter of the sensor. The return loss and VSWR simulation results of Hilbert sensor 4th order with dimensions 5 cm x 5 cm using IE3D software can be seen in Figure 3



(a)



(b)

Figure 3. Hilbert sensor S-parameter simulation using IE3D software (a) return loss (b) VSWR.

2.3. PD setup test

PD detection tests are carried out to produce PD signals from several types of discharge sources. In this research, a Hilbert fractal antenna sensor is used with the UHF method in detecting the discharge event that occurred. The PD detection test circuit can be seen in Figure 4.

220V / 22kV test transformer is used to raise the high voltage AC to produce a source of discharge. In the test circuit there is also a voltage divider circuit that functions to measure the output value on the transformer. In the test model the Hilbert fractal antenna is placed to detect the discharge signal which is then displayed on the oscilloscope.

In the PD detection test to determine the signal characteristics of the three types of PD consisting of corona, surface, and cavity, in the test circuit the voltage input variables and three different types of insulators are used as in Figure 5.

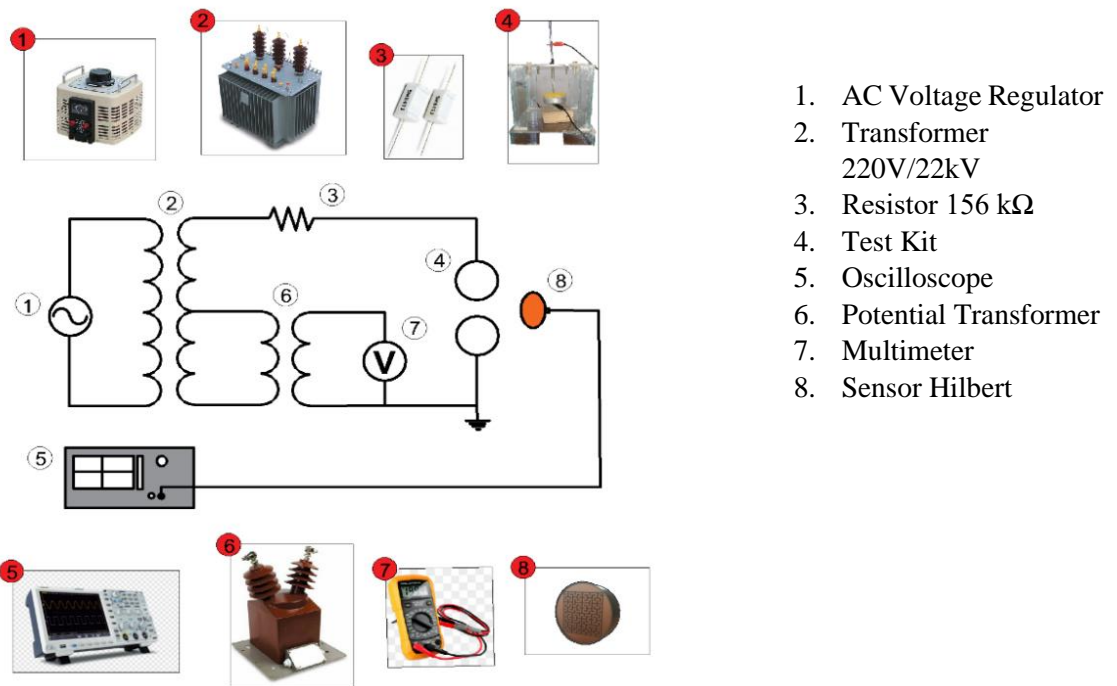


Figure 4. PD setup test.

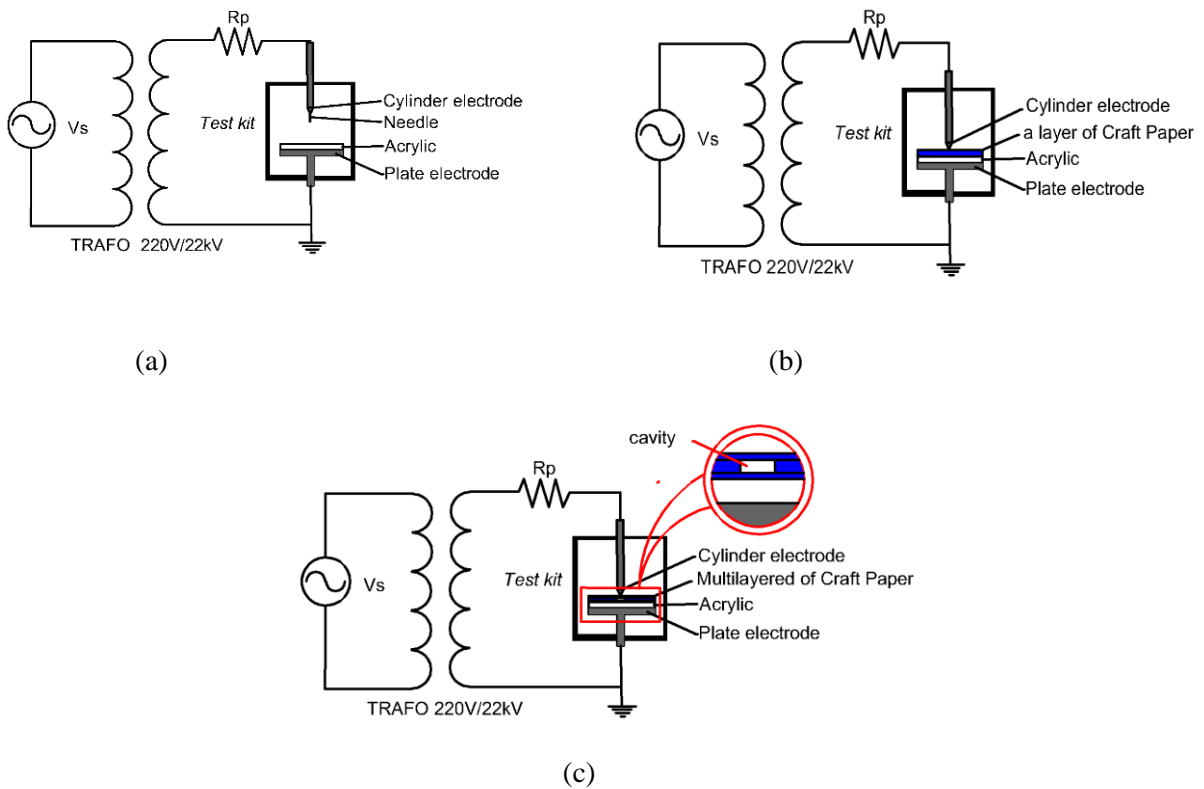


Figure 5. PD detection test circuit with various isolators (a) corona (b) surface (c) cavity.

In Figure 5a, the tip of the rod electrode, a needle is added and the two electrodes are separated by 5 cm. It is intended that the air acts as an insulator to produce corona type PD. The variable input voltage used ranges from 10-16 kV. In Figure 5b, a craft paper with a thickness of 0.2 cm is used as a test isolator to produce surface type PD. The variable input voltage used ranges from 0-10 kV. In Figure 5c, a layered craft paper with a 0.2 cm diameter hole in the middle is used to produce a cavity type PD source. The variable input voltage used ranges from 0-10 kV.

2.4. Wavelet denoising tool

In PD detection, sometimes the signal of the decay captured by the sensor is very small [5]. Unwanted signal interference (noise) is sometimes the main cause of the matter. Radio, television and telecommunications signals, as well as thermal noise are examples of the types of noise that can affect PD detection results. Therefore, to increase the sensitivity of PD detection, the amount of noise needs to be minimized [5]. There are many methods used in the process of denoising the signal, one of which is using Multivariate Wavelet Denoising. This method is useful for separating the noise signal with the original signal. As for Multivariate Wavelet Denoising using regression models as follows [13].

$$X(t) = f(t) + \varepsilon(t), t = 1 \quad (3)$$

Where $X(t)$ is a observed signal, $f(t)$ is the denoised signal and the $\varepsilon(T)$ is a spatial correlated noise signal.

In this research, 600 samples of the original signal data are then denoised using sym4-wavelet level 5 found in the MATLAB toolbox. The results of the PD signal denoising process can be seen in Figure 6 below.

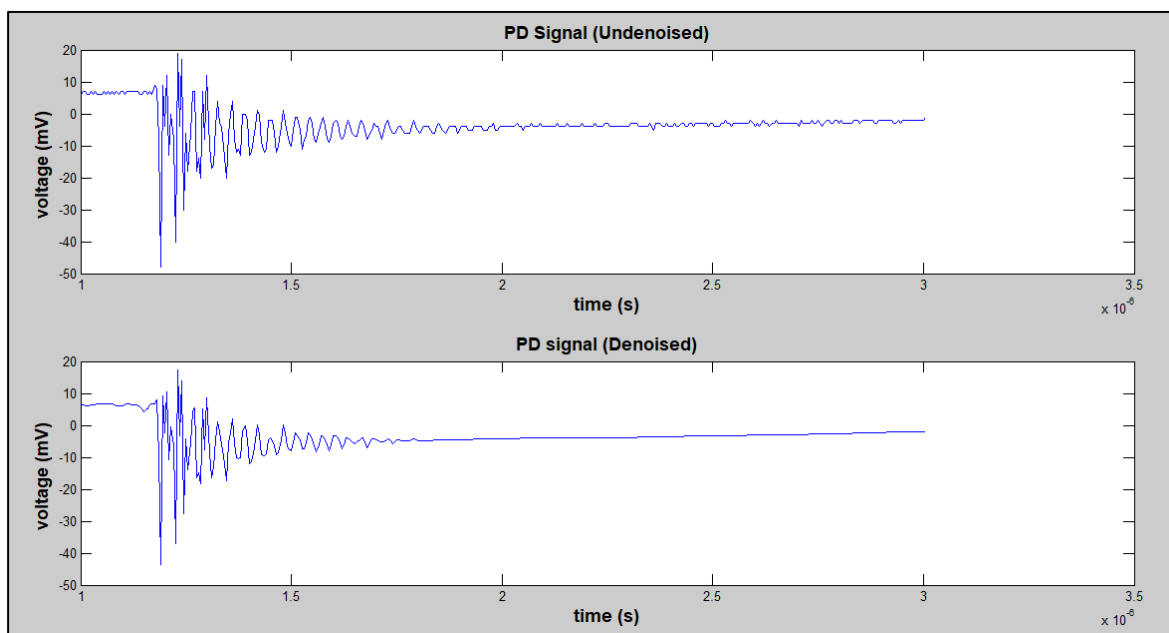


Figure 6. PD signal denoised using wavelet.

The process of denoising the signal does not always provide maximum results, there is still a possible loss of the original signal from the denoising process [13]. Therefore, it is necessary to review and consider first whether the process of denoising against the original signal is profitable or otherwise detrimental [13].

2.5. PD extraction and identification

The original PD signal and the denoising results are then extracted into statistical parameters consisting of mean, standard deviation, skewness and kurtosis. These parameters will be used as input to the neural network to identify the type of PD.

The PD type identification process is carried out using an artificial neural network (ANN) with back propagation type. Based on statistical parameter data, PD can be identified based on the source of discharge.

3. Results and Discussions

In each test, 200 sample discharge signals have been taken from the oscilloscope, bringing the total sample to 600 discharge signals. The average magnitude of the type of PD can be seen in Table 1 as follows.

Table 1. PD magnitude test results.

Type of PD	The Lowest Magnitude (mV)	The Highest Magnitude (mV)
Corona	124,76	294,47
Surface	19,26	36,46
Void	39,63	112,62

In Table 1 it can be seen that the magnitude of the corona type PD is greater than the surface and cavity type PD. The magnitude of the magnitude value at the corona discharge is thought to be due to the electromagnetic field moving from the needle electrode to the free electrode plate without any obstructions so that a large magnitude is generated. Meanwhile, for PD cavity type which has a magnitude greater than the surface type, this is presumably due to the air cavity that is inside the test isolator. The air cavity will bear a higher voltage in the discharge testing process compared to solid insulators due to differences in the permittivity coefficient between solid and gas insulators.

The denoising process to reduce the noise signal contained in the original signal begins by entering the original PD signal in the MATLAB software. A total of 600 samples of the original signal data are then denoised using sym4-wavelet level 5 found in the MATLAB toolbox.

The original signal and denoising results are then extracted into statistical parameters which can be seen in the following Table 2 and Table 3.

Table 2. Statistical data of undenoised PD signal

Statistical Parameter	Type of PD (mV)		
	Corona	Surface	Void
Mean	207,46	29,09	60,35
Skewness	-0,31	-1,41	-0,76
Kurtosis	1,75	11,47	5,81
Deviation Standard	16,03	3,48	10,73

Table 3. Statistical data of denoised pd signal

Statistical Parameter	Type of PD(mV)		
	Corona	Surface	Void
Mean	207,46	29,08	60,29
Skewness	-0,280	-1,16	-0,68
Kurtosis	1,60	9,74	5,49
Deviation Standard	15,93	3,30	10,48

PD type identification using ANN back propagation type consists of the training process (train dataset) and testing (test dataset). 450 of the 600 PD signal statistical data are used as input in the training process (train dataset). The training process (train dataset) is completed when the mean square error (MSE) of 0.01 is reached. This is shown by the training data performance graph in Figure 7.

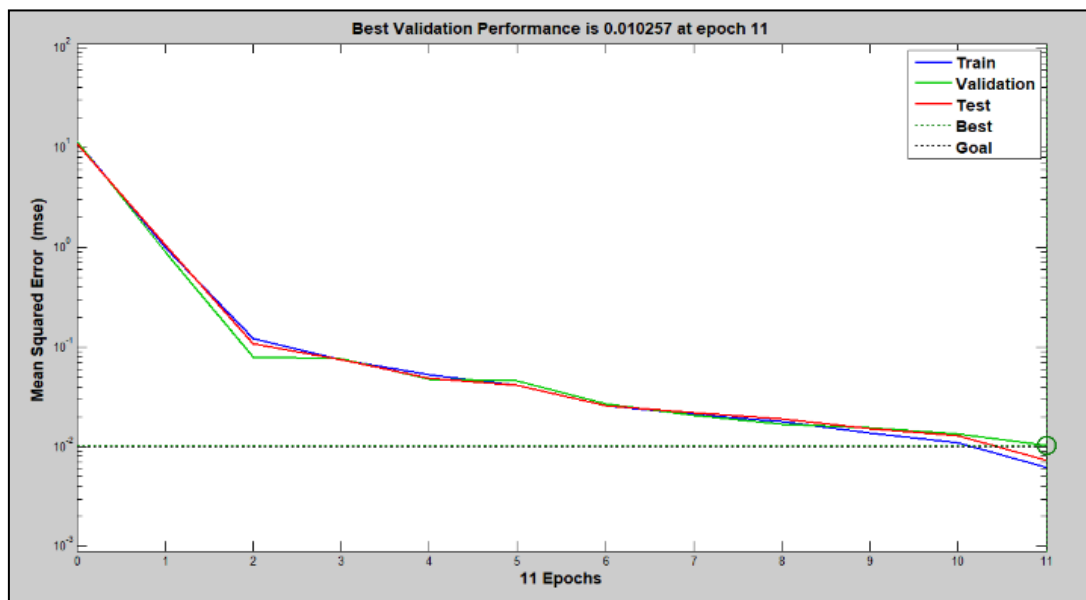


Figure 7. Mean square error (MSE) graph of training data (train dataset) ANN back propagation type.

The PD type identification process is then continued through testing (test dataset) using the remaining 150 PD statistical data. The graph of the results of identification of type PD by ANN back propagation type can be seen in Figure 8.

Based on Figure 8 that shows the test results (test dataset) identification of PD type based on the source of discharge, it can be seen that the x-axis is 150 sequential PD static data and the y-axis is the target target value. The red graph shows the test target that must be achieved at the PD type identification output value, while the blue graph is the result of PD type identification output. In the testing process of 150 PD signal statistical data, it can be seen that the first data up to the 50th data are corona type discharge signal data marked as target 1, 51st to 100th data are surface type discharge signal data (surface discharge) marked as target 2, and the 101st to 150th data are void discharge discharges marked as target 3. Prior to the denoising process as shown in Figure 8a, there are several identification outputs the type of PD that is not in accordance with the test target is proven by the output graph that does not coincide with the test target graph.

However, after a denoising process on the PD signal is shown in Figure 8b, errors from the neural network in identifying the type of PD can be minimized. The error (result) identification of the type of PD by ANN allegedly can be caused by high levels of noise in the PD signal data. In addition, errors in the process of identifying the type of PD sometimes originate from ANN itself or can also be caused by errors in the detection of PD. To minimize the level of error (ANN) in identifying the type of PD caused by noise, can be overcome by denoising the PD signal. On the other hand, to overcome errors (errors) originating from ANN itself, can be minimized by increasing the amount of PD training data. If the error (error) identification results caused by inaccurate detection of PD can be minimized by increasing the precision of the measuring instrument.

Overall, the process of detecting and identifying the type of PD in this study has been successfully carried out with fairly accurate results. If comparing the output value with the PD target data, then the percentage of ANN accuracy can be calculated in identifying the type of PD. The results of the ANN

accuracy comparison test in identifying the type of PD between the original discharge signal and the signal from the denoising process can be seen in Table 4.

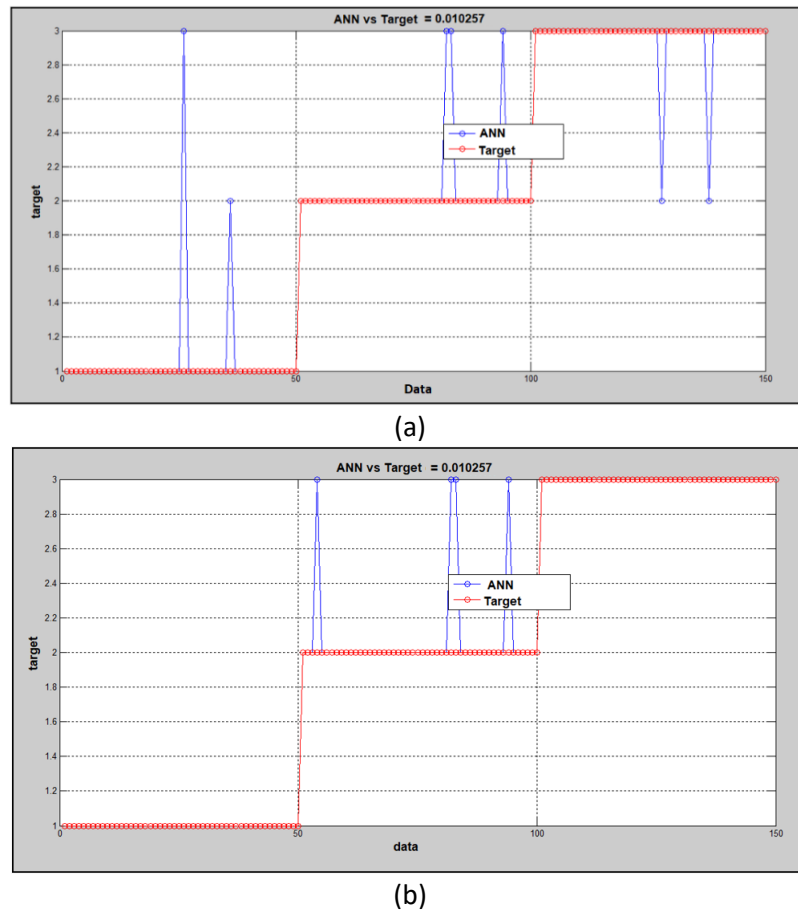


Figure 8. Graphs of PD type identification results (a) Before the denoising process (b) After the denoising process.

Table 4. The results of the ann accuracy level

PD type	Sample number	Correct identificate	
		Original signals	Denoised signals
Corona	50	48	50
Surface	50	47	46
Void	50	48	50
Accuracy (%)		95,33%	97,33%

Based on Table 4, the corona type PD consisting of the original discharge signal and the denoising signal has the difference in the number of true samples in the identification process. Corona original signal identification produces 48 correct samples from a total of 50 samples, while for the signal from the denoising process, produces 50 correct samples from a total of 50 samples in the identification process. At the surface type discharge, the number of true samples in the original signal is 47 samples from a total of 50 samples and after the denoising process the number of true samples drops to 46 samples.

At the discharge of the cavity type obtained the number of true samples on the original signal as many as 48 samples from a total of 50 samples and after the denoising process carried out the number of true samples increased to 50 samples. For PD type identification results based on Table 4, it can be analyzed that the denoising process has little effect on corona and cavity type discharge signals in improving the accuracy of identification of PD type by ANN, whereas for surface type discharge signals, denoising process reduces the level of accuracy of PD type identification by ANN. This is presumably because the denoising process can sometimes eliminate the characteristics of the PD signal or it may also be due to inaccuracy in the detection of PD. Based on the results of the identification of the type of PD in this study, obtained a large percentage of the level of accuracy of the identification of the PD signal by ANN that is equal to 95.33% for the original signal and 97.33% for the denoising signal.

4. Conclusions

PD detection using the Hilbert fractal antenna sensor has been successfully carried out by each producing 200 surface discharge, void discharge, and corona discharge signals. In this study, the process of identifying the introduction of PD types based on the source of discharge has been successfully carried out. In data extraction, statistic parameters consisting of mean, standard deviation, skewness, and kurtosis are generated from discharge signal data. This is done to reduce the size of the data that is too large, but is still recognized by ANN. The denoising process on the discharge signal does not always provide an effective result at the signal sealing level by ANN because there is still the possibility of losing signal characteristics due to the denoising process.

Acknowledgements

The authors would like to express their gratitude to Kemenristek-DIKTI Indonesia for supporting this research. This research was supported by Kemenristek-DIKTI Indonesia with the Fundamental Research Grant, contract number: 857/UN26.21/PN/1999.

References

- [1] Bartnikas R 2003 Partial Discharge , Their Mechanism, Detection and Measurement *J.IEEE Trans. on Dielectrics and Insulation* **9** 763
- [2] Garnacho F and Trasmonte I 2008 On-Site Measurement s experiences in insulation condition for medium and high viltage cables *CIGRE*, **D1.201**
- [3] Phung B T 1997 Computer-based Partial Discharge Detection and Characterisation," *PhD Thesis Department of Electrical Power Engineering, University Of New South Wales, Sydney*, 1997.
- [4] Sinaga H H, Sitorus H B H, Permata D, Yuniati Y and Vraja R B 2020 Denoising of partial discharge waveforms using multivariate wavelet method, *IOP Conference Series: Materials Science and Engineering* 857(1)
- [5] Contin A, Cavallini A, Montanari G C, Pasini G and Puletti F 2000 Artificial Intelligence Methodology for Separation and Classification of Partial Discharge Signals *Annual Report Conference on Electrical Insulation and Dielectric Phenomena* 522-526
- [6] Cavallini A, Conti M, Contin A and Montanari G C 2003 Advanced PD Inference in On-Field Measurements II. Identification of Defects in Solid Insulation Systems *J. IEEE Transactions on Dielectrics and Electrical Insulation* **10** 528-538
- [7] Miller R K, Shu F, Nunez A and Ternowcheck S 2003 Advances in Accoustic Emission Testing for Detecting , Location and Assessing Electrical and Thermal Faults *EPRI 2003: Substation Equipment Diagnosis Conf*
- [9] Sinaga H H, Sitorus H B H, Permata D and Soedjarwanto N 2019 Fractal Hilbert Sensor to Detect Partial Discharge on Transformer, *Journal of Engineering and Scientific Research (JESR)*, **1**(2) 94-100

- [10] Sinaga H H, Phung B T and Blackburn T R 2012 UHF sensor array for partial discharge location in transformers, *Proceedings of 2012 IEEE International Conference on Condition Monitoring and Diagnosis* 979–982
- [8] Muhr M, Strehl T, Galski E, Feser K, Gockenbach E and Hauschild W 2006 Sensor and Sensing Used For Non Conventional PD detection *Cigre D1-102_2006*
- [11] Wang Y, Wang Z and Li J 2013 UHF Moore Fractal Antennas for Online GIS PD Detection *J. IEEE Antennas and Wireless Propagation Letters* **16** 852-855
- [12] Li J, Jiang T, Wang C and Cheng C 2012 Optimization of UHF Hilbert Antenna for Partial Discharge Detection of Transformers *J. IEEE Trans Antennas and Propagation* **60** 2536-2540
- [13] Aminghafari M, Cheze N and Poggi J M 2006 Multivariate de-noising using wavelets and principal component analysis, *Computational Statistics & Data Analysis*, **50** 2381-2398