

# Smart Monitoring of Electrical Quantities Based on.pdf

# Smart Monitoring of Electrical Quantities Based on Single Board Computer BCM2835

Dikpride Despa, Ady Kurniawan, M. Komarudin, Mardiana, Gigih Forda Nama

Departement of Electrical Engineering  
University of Lampung  
Lampung, Indonesia

despa@eng.unila.ac.id, adykurniawan18@gmail.com, komar@eng.unila.ac.id, mardiana@eng.unila.ac.id, gigih@eng.unila.ac.id

**Abstract**— Electricity network needs to be monitored, especially for Voltage (V) measurement, current (A), power factor ( $\cos \theta$ ), power (W), and energy consumption (kWh). Monitoring is important, in order to know the quality of electricity supply in the system, identifying disruption events, and to calculate the amount of electrical energy consumption periodically. To achieve the objectives mentioned above, we have made device that can be monitor the electrical quantities in real time, recorded data was stored in to database system, and web application processed this data and shown the statistic reports through a web interface. This research was conducted on the 3 phase electricity at The Integrated Laboratory of the Electrical Engineering Department University of Lampung. Monitoring of voltage, current and energy consumption was done by using a step-down transformer as a voltage sensor, ACS712-30A as current sensors for capture the flow measurement, and TEM015-D4250 kWh meter for measuring energy consumption. Power and Power Factor value was obtained by some of scientific calculation. We used Python programming language for data processing measurement and calculation, running on BCM2835 Single Board Computer. The results of measurements include voltage, current, power factor, power, and the amount of energy consumption was stored in to data base, and data report can be accessed online using web browser.

**Keywords**— 3-phase electrical networks, voltage sensors, current sensors, kWh meters, energy consumption, BCM2835 single board computer.

## I. INTRODUCTION

Electric energy has an important role in promoting the economy of the community, a lot of equipment that requires electricity to operate, both in scale household and industrial scale. The quality of electrical energy such as voltage, current, and power factor is very important to know, because it can affect the performance and service life of the load or equipment used.

In addition, the amount of electrical energy consumption every day, every week or every month as well needs to be known in order to determine the measures to make savings in

electrical energy consumption and in turn is expected to reduce the cost of utility bills.

To achieve objectives above, it should be created a system that can monitor the amount of electricity that include voltage, current, power factor, power and huge consumption of electrical energy that can record data during the monitoring done and access it remotely in WEB facilities that would be more effective and efficient in terms of monitoring and control.

In this research, system monitoring is done by using a digital meter kWh equipped with current sensors and voltage sensors for current and voltage of monitoring. Furthermore, power and power factor are calculated based on information obtained from third such equipment.

Single Board Computer programming BCM2835 or commonly called by the name Raspberry pi is used in programming. results of the measurements can be directly displayed and recorded in a database. Raspberry pi can also be directly connected to the Internet like a PC, thus monitoring can be done from distance.

## II. LITERATURE REVIEW

### A. Electric Current .

Electric current is the amount of charge that flows in a conductor in one second (coulombs per second) [6] which is measured in amperes (A). Electric current can be formulated with the following equation: [6]

$$I = \frac{Q}{t} \quad (1)$$

Where: I = electrical current in amperes (A)  
Q = electric charge in coulombs (C)  
t = time in seconds (s)

**B. Voltage.**

Electric voltage is the potential energy difference between two points in volts (V). The voltage can also be interpreted as joule per coulomb [6]

$$V = \frac{E}{Q} \tag{2}$$

Where: V = Voltage in volts (V)  
 E = Energy in joules (J)  
 Q = Charge in coulombs (C)

**C. Electric Power and Electric Energy.**

Electric power is the amount of electrical energy that flows every second or joules per second [6] in watts (W). Electrical power is defined by the following equation: [6]

$$E = P \cdot t \tag{3}$$

$$P = \frac{E}{t} \tag{4}$$

Where: P = Power in watts (W)  
 E = Energy in units of joules (J)  
 t = time in seconds (s)

Electrical energy is defined as the rate of power consumption multiplied by time. [1] Unit for electrical energy on international standards is Joule (J), but in everyday life is better known as kilowatt-hour (kWh). Power in the electrical system of Alternative Current (AC) is divided into; complex power (S) with the unit VA, active power (P) with the unit Watt and reactive power (Q) with a unit of Volt Ampere Reactive (VAR). [1]. Relations between the three types of power above can be explained with sketches power triangle as shown in Figure 1.

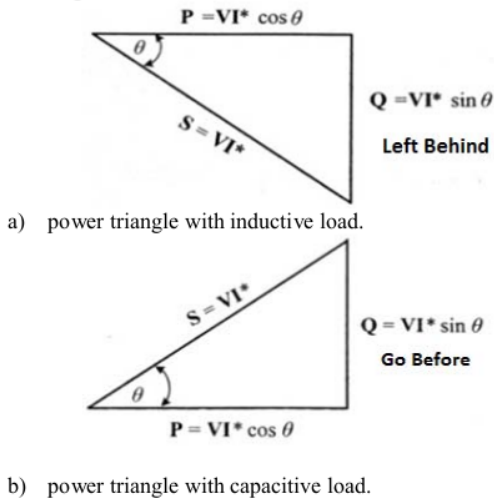

Figure 1. Power Triangle [1]

The components of the power triangle can be written as follows: [1]

- Active power :  $P = VI \cdot \cos \theta$  (W) (5)
- Reactive power :  $Q = VI \cdot \sin \theta$  (VAR) (6)
- Complex power :  $S = VI \cdot (VA)$  (7)
- Power factor :  $\cos \theta = p.f$  (8)

If the circuit is inductive, the current phase will be left out of phase voltage, if the circuit is capacitive, the current phase will precede the phase voltage, whereas if the circuit is resistive then the current will be in phase with the voltage that the phase angle ( $\theta$ ) = 0. The angle  $\theta$  determines the value of power factor (pf), whereas pf is the cosine of the angle  $\theta$  value. Pf value is often used as an indicator of the quality of the power supply system. System good if pf value = 1 or close to the value of 1.

**D. Related Works.**

Previous studies that a reference in this research are: research that explains how to do an online monitoring of the power system using the sample data recorded on the PMU (Phasor Measurement Unit) are placed at various locations [2] [3] In addition to the other preliminary studies related to monitoring server system and Internet connection Mini-Based Single Board Computer BCM2835 also be referenced in this study [4][7][14]. On work [8] describe Design of Data Recorder kWh Meters Distance-Based Microcontroller has produced a device to calculate the energy consumption of the household. Device made consists of two parts: a transmitter and a receiver. Transmitter is applied on the kWh meter, while the receiver is used to see the results of the calculation of a distance using wireless. To get the value of the energy consumption is only used current sensors, and to process the data used microcontroller and subsequently also been no previous research on the electrical connection and monitor the temperature [5] Data monitoring results are stored in a MySQL database and can be viewed on the web in graph form. On works [9][10] presented the electricity measurement research based on microcontroller. The principal of Electrical measurement was also discuss on paper [11][12][13].

**III. RESEARCH METHODOLOGY**

**A. System Block Diagram**

Power source 3-phase kWh meters into the digital, then to the current sensor and a voltage sensor, connected to the electrical load is used. kWh meter readings can be sent directly to the Raspberry Pi, while the current sensor readings and sensor voltage to go through the ADC first before being sent to the Raspberry Pi. Furthermore, Raspberry Pi is a place made to store the results of monitoring programs into the database and displays it to the WEB. System block diagram is shown in Figure 2.

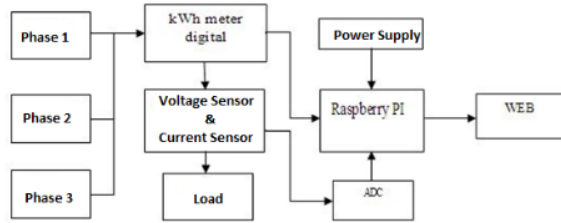

Figure 2. Block Diagram System

### B. Hardware Design

#### 1) Voltage Sensor Circuit

In designing the sensor voltage, step-down transformers are used to lower voltage from the high voltage level to a low voltage level. Because the output of transformers is still in AC voltage while Raspberry Pi was designed using a DC voltage source, required signal conditioning circuit which is a rectifier and voltage divider functions to obtain a DC voltage so that the voltage can be read by ADC. Then it will be converted into a digital signal to be transmitted to the Raspberry Pi. Voltage sensor networks are made as shown in Figure 3.

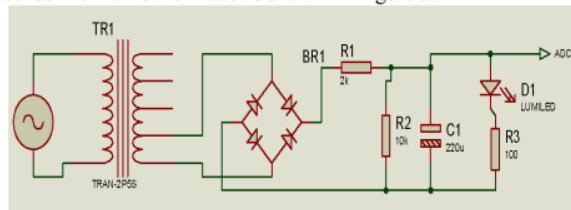

Figure 3. Voltage Sensor Circuit

#### 2) Current Sensor Circuit

30A ACS712 is used in current sensor circuit, this sensor will provide an output voltage that is linear with current changes measured. ACS712 output signal depending on the input signal. In this experiment, the measured current is AC current so that rectifier diode should be added in order to obtain a DC signal and the output can be read by ADC. Maximum sensor output voltage is 5V because of that it should be lowered to 3.3V voltage level (the voltage that is safe for Raspberry Pi) using a voltage divider circuit. Capacitors are used as filters to get a good output signal. Sensor networks was made as shown in Figure 4.

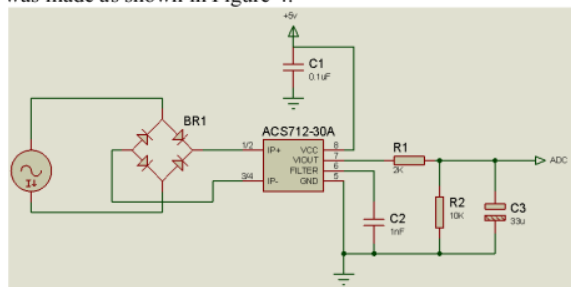

Figure 4. Flow Sensor Networks

#### 3) kWh Digital Meter

kWh meter with TEM015-D4250 type is used in this study. kWh meter is used to measure the energy consumption so that the power value can be determined by dividing the value of kWh between time.

#### 4) BCM2835 Single Board Computer

Single Board Computer BCM2835 or commonly called the Raspberry Pi is a credit card-sized computer developed by the Raspberry Pi Foundation, which has a function similar to most PC.

Monitoring is done on a scale electric power 3-phase network, hence the required sensor 3 respectively. Of all these sensors will get the voltage V (Volt), current I (Ampere), power factor pf (cos  $\theta$ ), load power P (Watt), and E energy consumption (kWh) for each phase. The value of voltage, current and power consumption can be seen in sensor readings. While the power factor and power is the result of calculation. connection between sensors and Raspberry Pi is shown in Figure 5.

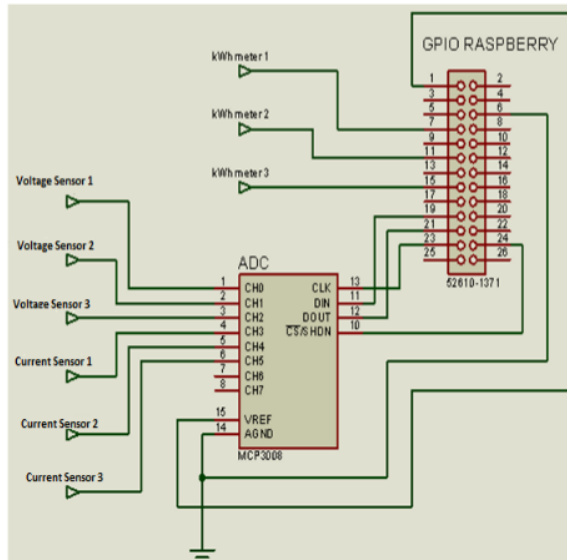

Figure 5. Connection Sensor with Raspberry Pi (BCM2835)

### C. Program Design

The program used is Programming Python by using the Raspberry Pi. The program includes:

- Reading of the measurement sensor,
- The calculation to obtain the desired quantity,
- Record the results of measurements in a database and displays in WEB

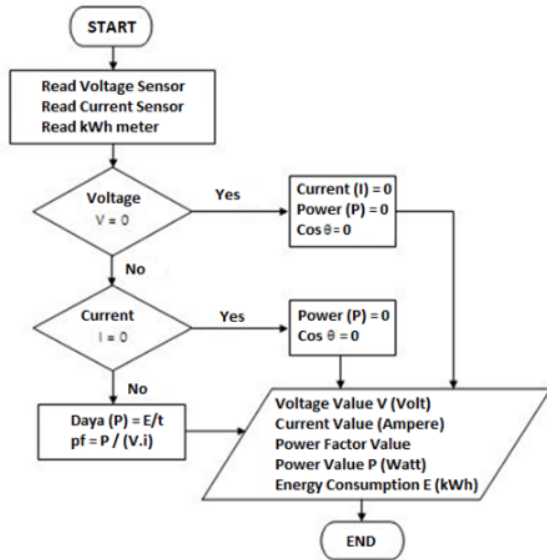

Figure 5. Flow Chart Program.

From Figure 5., output of the system is the value of Voltage, Current, Cos θ, power, and large energy consumption, can be explained as follows:

- Rated voltage obtained from the voltage sensor readings.
- The current value obtained from the current sensor readings ACS712-30A.
- Energy consumption value obtained from kWh meter digital readings.
- Value kWh is the product of power by time, so if the value of kWh have known the value of the power can be calculated using equation (3) and (4)

$$E = P.t (Wh)$$

$$E = (P.t) / 1000 (kWh)$$

$$P = E / t$$

Where: P = Power (Watts)  
E = energy consumption (kWh)  
t = time (hours)

Then, after the value of Voltage, Current and Power are determined then the power factor pf (cos θ) can be calculated using equation (5) and (8).

$$P = V . I \text{ Cos } \theta$$

$$Pf = P / (V . I)$$

Where: P = Power (Watts)  
V = Voltage (Volt)  
I = Current (Amperes)  
Pf = Power Factor (cos θ)

#### IV. RESULTS AND DISCUSSION

##### A. Voltage Sensor Testing.

Testbed was done by using the voltage sensor analog voltmeter, digital voltmeter and sensors, then comparing the results of measurements among those three instrument devices. test results as shown in Table 1. below.

Table 1. Data Results Voltage measurement

No.	Measurement Result				
	Voltmeter Analog	Voltmeter Digital	Sensor 1	Sensor 2	Sensor 3
1	190	190	189,43	192,35	190,08
2	200	201	199,75	202,77	199,77
3	210	210	209,37	212,28	210,32
4	220	221	219,33	220,89	219,44
5	231	230	229,66	231,31	230,55
6	240	241	240,34	240,82	240,24

##### B. Current Sensor and kWh meter Testing.

Testbed was done by providing the electrical load power value change, Burden used are incandescent lamps, fans, water heaters and irons. tested is a current sensor and kWh meter, but the voltage sensor is also used in order to obtain the value of power factor using the program. Results of this testing is shown in Table 2.

Table 2. Data Results Current and kWh Testing.

No	Measurement Result								
	I (Ampere)			Pf (cos θ)			P (Watt)		
	Sensor	Analog	Digital	Sensor	Analog	Digital	Sensor	Analog	Digital
1	1,54	1,8	1,78	0,999	0,995	0,999	391,3	390	376
2	2,2	2,2	2,2	0,966	0,992	0,997	473,68	475	465
3	3,74	3,7	3,7	0,965	0,998	0,999	800	818	797
4	5,28	5,2	5,28	0,999	0,999	0,999	1125	1165	1145

Based on the data of voltage, current, power and power factor measurement indicates that the results of measurements using sensors have a small scale difference results if compared with the results of measurement using an analog measuring device and digital measuring devices, so that the sensors are made fairly used for monitoring system of electrical quantities on the panel.

##### C. Testbed Environment.

Testbed performed on 3-phase electrical panel in the Integrated Laboratory of Electrical Engineering Unila floor 2<sup>nd</sup>. The first step is to install the hardware that made the three-phase electrical panel before going to the load, then make the database as a repository for monitoring results using Python programming, and the final step is to show the existing data in the database to the web in graphs. In this test, the Database was made into 5 tables for each measurement, include Voltage, Current, Power, Power Factor and Energy Consumption measurement. The measurement results are displayed in graphical form. Monitoring charts for each of the measurements is shown in Figure 6, Figure 7, Figure 8, and

Figure 9. The graph is the result of monitoring on May 27, 2015 at 16:15 until May 29, 2015 at 05:59.

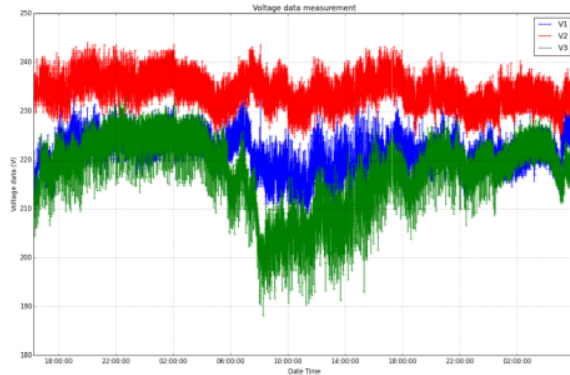

Figure 6. Voltage Monitoring Graphs

From the graph of voltage monitoring results shown in the figure 6., it appears that inter-phase voltage unbalance, the highest voltage contained in the second phase to reach 240 volts, while the lowest voltage contained in the third phase which reaches 200 Volts. This occurs because the load is not balanced between the three phases. If More load mounted on a phase, the voltage drop that occurs in these phases will be greater or vice versa. Loads in this term is all of loads which are connected to the three-phase power source from PLN. Voltage in phase 2 relatively constant for 24 hours while the phase 1 and phase 3 voltage during the day tended to decline compared to the voltage at night, it shows that loads in phase 1 and phase 3 during the day is greater than the loads at night.

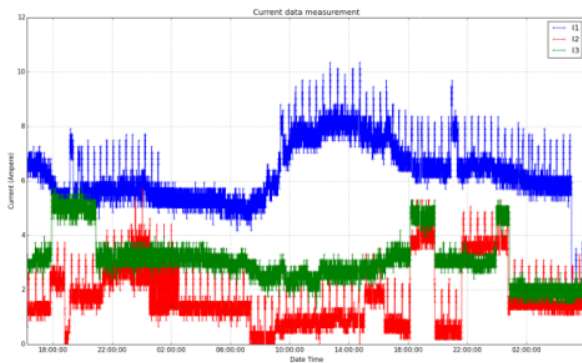

Figure 7. current Monitoring Graphs.

From the graph result of current monitoring in Figure 7, shows that the currents between phases in Electrical Engineering Laboratory is not in balance. The largest current value is allocated in phase 1 from 5 A to 9 range, the second phase is relatively constant between 2 A to 4.8 A. While the smallest currents are allocated in phase 3 with 0 A to 5 A range. Based on these three phases ,Measured current in the day is greater compare on the night. it can be happened

because more activities in laboratory are done during the day while in the night were only used for lighting.

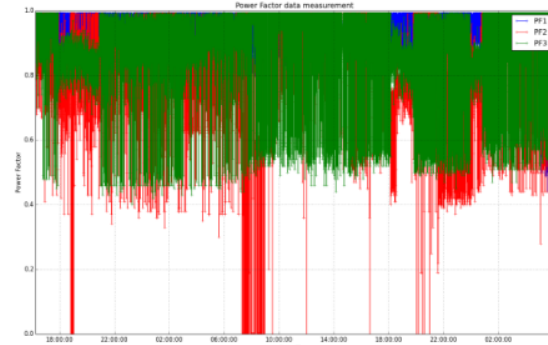

Figure 8. Power Factor Monitoring Graphs

Figure 8 is the power factor monitoring charts, where the value of the power factor is obtained from the calculation using the measurement data of voltage and current. the graph shows that the power factor phase 1 and phase 3 ranged from 0.8 to 0.99. For phase 3 power factor value decreased to 0.5 and 0.6 but did not last long. While the power factor on phase 2 looks not in stable ranging from 0.6 to 0.99. Factors that affect the value of the power factor is a reactive load, so if the value of power factor is unstable probably it caused by the changes of reactive power in load. Power factor on phase 2 several times reached a value of 0, it is because the current value at this time is 0 (can be seen in the graph Figure 4.2, while the program can not calculate the value of the power factor if the value of current or voltage is 0, so the program is automatically provide output power factor is 0.

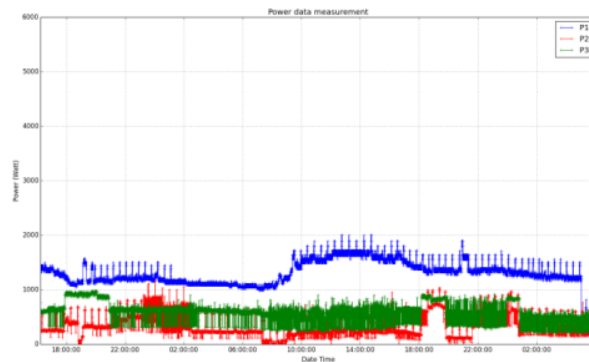

Figure 10. Power Monitoring Graphs

Graph in Figure 10 shows that the load is not balanced between the three phases. The biggest load is allocated in phase 1 while the smallest load is in phase 2. This condition occurs because phase 1 is connected to the laboratories on the first floor. Most laboratories in first floor need large power consumption in order to operate the machines and motors. While phase two connected to less laboratories energy consumption as well.

From the results of kWh meters in monitoring consumption of electrical energy, obtained the largest electric energy consumption is in phase 1 and the smallest in phase 2. This is due to the phase 1 is connected to machines that use a lot of electricity with high power consumption, while phase 2 is connected with laboratory practicum when not much use electrical equipment with high power. Online condition of power monitoring on the web can be seen in the results are shown in Figure 10.

## V. CONCLUSION AND RECOMMENDATION

### A. Conclusions

After the measurement, monitoring and data analysis can be concluded that:

- The consumption of electrical energy in the Integrated Laboratory of Electrical Engineering for each phase is not in balance. This is because of the use of uneven load on each laboratory.
- From the chart patterns of energy use, it appears that electrical energy during the day more usage when compared to the night, it is because most research and activities in laboratory carried out during the daytime.

### B. Recommendations

In order to make this system better, some miraculous things that needs to be done are:

- Current sensor ring type transformers should be used, so that the installation does not need to disconnect the power source to the load.
- For programming and WEB database should use assistive computer that has better specs compared Raspberry Pi, so that Raspberry Pi is only used for programming the sensor readings.
- Devices that have been made can be used for one place monitoring only, a remote control circuit can be developed in order to make it more efficient and useful. This research can be developed in order to monitor more than one electrical panel by adding sensors without adding Raspberry Pi.

## REFERENCES

- [1] Adityawarman Dimas, "Rancang Bangun Alat Ukur Arus Menggunakan Transformator Arus Berbasis Mikrokontroler ATmega32", Universitas Lampung, 2014.
- [2] Dikpride Despa et.al, "PMU Based Monitoring and Estimation Power System Dynamic Stability Developed on 50-Hz Power System", Proceeding of Power and Energy Systems (AsiaPES 2012), 2012.
- [3] Dikpride Despa et.al, "PMU Based Monitoring and Estimation of Inter-area Power Oscillation for Singapore-Malaysia Interconnection Power System", Journal of Energy and Power Engineering, USA, 2012.
- [4] Gigih F N, "Rancang Bangun Sistem Monitoring Sambungan Internet Universitas Lampung Berbasis Mini Single Board Computer BCM2835", Prosiding Seminar Nasional Sains & Teknologi V, 2013.
- [5] Gigih F N, M Komarudin, Hanang P, Mardiana, and Hery D S, "Electricity, Temperature, and Network Utilization Monitoring at Lampung University Data Centre Using Low Cost Low Power Single Board Mini Computer", Conf. RC-CIE, Yogyakarta Indonesia, 2014. Pp 184-189, 2014.
- [6] Fowler, Richard J, "Electricity Principles & Applications, Penerbit McGraw-Hill", 2008.
- [7] Mardiana, Wahyu E. S. Johan, "Sistem Monitoring Server Berbasis SMS (Studi Kasus : Server Siakad Unila)", Electrician, Jurnal Rekayasa dan Teknologi FT Unila Vol.2.No.3, 2008.
- [8] Pratomo, Vektor A, "Rancang Bangun Pencatan Data kWh meter Jarak Jauh Berbasis Mikrokontroler. Universitas Budi Luhur", 2012.
- [9] Rusti, Dayita A, "Monitoring Pemakaian Energi Listrik Berbasis Mikrokontroler Secara Wireless. Politeknik Elektronika Negeri Surabaya", 2011.
- [10] Suryawan, Dwi Wahyu, "Rancang Bangun Sistem Monitoring Tegangan, Arus dan Temperatur Pada Sistem Pencatu Daya Listrik Di Teknik Elektro Berbasis Mikrokontroler Atmega 128. Universitas Diponegoro", 2012.
- [11] Thamrin Ihsan, "Perancangan kWh Meter Digital Menggunakan Sensor Arus ACS712ELC-30A. Universitas Komputer Indonesia", 2010.
- [12] Tumanski S, "Principles of Electrical Measurement, Penerbit Taylor & Francis Group", 2006.
- [13] Waluyanti Sri, "Alat Ukur dan Teknik Pengukuran. Penerbit Direktorat Pembinaan Sekolah Menengah Kejuruan", 2008.
- [14] Zulkarnain Novan, "Energy Monitoring System Berbasis Web. Universitas Bina Nusantara", 2013.

# Smart Monitoring of Electrical Quantities Based on.pdf

---

ORIGINALITY REPORT

---

# 13%

SIMILARITY INDEX

---

MATCH ALL SOURCES (ONLY SELECTED SOURCE PRINTED)

---

★eprints.undip.ac.id

Internet

< 1%

---

EXCLUDE QUOTES ON

EXCLUDE MATCHES OFF

EXCLUDE BIBLIOGRAPHY ON