

PAPER • OPEN ACCESS

Sensitivity test of electromagnetic sensor using closed type transverse electromagnetic (TEM) cell

To cite this article: H H Sinaga *et al* 2020 *IOP Conf. Ser.: Mater. Sci. Eng.* **857** 012018

View the [article online](#) for updates and enhancements.

Sensitivity test of electromagnetic sensor using closed type transverse electromagnetic (TEM) cell

H H Sinaga^{1,*}, R B Vraja¹, H B H Sitorus¹, D Permata¹ and Y Yuniati¹

¹ Department of Electrical Engineering, Universitas Lampung, Jalan Prof. Soemantri Brojonegoro No. 1, Bandar Lampung 35145, Indonesia

*Email: herman.h.sinaga@eng.unila.ac.id

Abstract. Electromagnetic method is one of the proved successfully applied to detect the presence of partial discharge events on electrical insulation. This method applied by utilized an electromagnetic sensor that capable to capture the electromagnetic signals generated by the partial discharge source. The sensors need high sensitivity to be able to capture the very small electromagnetic signals. Thus, the sensors need to be tested its sensitivity to make sure its ability to capture the electromagnetic sensor generated by the partial discharge source. In this research, a Transverse Electromagnetic (TEM) cell is applied to test the sensor sensitivity. The TEM cell is a close cell type which provide better noise insulation and has frequency response up to 1 GHz. The experiment results show the TEM cell can be used to test the sensor sensitivity. The sensor sensitivity is much depending on the sensor dimension. The larger the sensor the higher its sensitivity. Future research should be arranged to test the sensor sensitivity to capture wide bandwidth PD signals.

Keywords: Sensitivity Test, Partial discharge, Electromagnetic sensor, TEM cell

1. Introduction

Partial discharge (PD) events in electrical insulation will produce electromagnetic signals that transverse in all direction outward the partial discharge sources. So, to be able to detect the presence of the partial discharge, one can utilize the electromagnetic signals by using appropriate method. Method to detect the presence of the PD in electrical insulation is known as electromagnetic method. This method applied to detect the electromagnetic signals generated by the PD sources by using an antenna which is acts as electromagnetic sensor [1,2]. Other researchers have pointed out the electromagnetic sensors to detect the presence of the PD's [1-5]. The electromagnetic method has proven its ability to detect PD in varying type electrical insulation such as transformer [2] and gas insulated switchyard (GIS) [6,7]. However, there is a drawback of the using of the electromagnetic method, i.e. it is difficult if not impossible to calibrate. To convert the electromagnetic measurement results is almost impossible to do due to the nature of the electromagnetic signals itself [8,9]. The electromagnetic signals will travel all-around of the PD source thus the signals will attenuate along its path. This will cause the magnitude of the electromagnetic signals heavily depends on the electromagnetic signal path [9] and not the distance of the sensor to the PD sources [10]. Thus, without knowing the exact location of the PD source, the magnitude of the electromagnetic signals cannot be converted to a more



convenient unit charge coulomb [9].

To override the calibration inability, CIGREE TF 15/33.03.05 [11] propose sensitivity test for the electromagnetic sensor. The sensor sensitivity test conduct inside a uniformly electromagnetic chamber, which commonly known as transverse electromagnetic (TEM) cell. In this paper, discussed the using of a closed type TEM cell to test the sensor sensitivity.

2. Sensor Sensitivity Test

In every measurement system, calibration which compares the output of a piece of measuring equipment to a standard value is required. The calibration establishes with certainty the amount being measured. However, this is not the case for the electromagnetic detection method. The output of the electromagnetic sensors cannot be calibrated as per IEC 60270 as they do not directly quantify the amount of charge of the PD pulses [11].

The reason is that a PD can occur at almost any location inside the transformer tank. The path of the electromagnetic signals from the PD source to the sensor is affected by the structure inside the transformer. The PD signal propagation can be obstructed by some solid material parts inside the transformer. The active parts of the transformer also affect the attenuation of the electromagnetic signals which caused the attenuation not linear to the distance. Thus, without knowing the exact location of the PD, it is difficult to convert the amount of PD detected by the electromagnetic sensor to an equivalent pC level [10].

To provide information about the sensor capabilities, it is important to set up tests which are repeatable and can be used to test various sensors. In [10,12] sensor calibration is introduced and information is provided about the sensor frequency response. A μ -TEM cell was used in [13] to test antenna response. In [14, 15], a TEM cell was built to test the sensor frequency response in an attempt to calibrate the sensor for PD detection. The TEM cell can also be used to test the sensor response for specific pulses such as the step pulse [16] in order to find the most suitable sensor for application of PD diagnostic and monitoring. Using a step pulse to determine the frequency response of the sensors has an advantage over the sweep frequency generator [16]. This is because the step pulse contains all necessary frequency components so only one measurement is needed. Also, the cost of the test can be reduced as the frequency generator can be eliminated. However, the sweep frequency generator will provide real frequency response where input and output can be compared directly, unlike the step pulse where the pulse signals must be converted to frequency response.

As the electromagnetic sensors cannot be calibrated based on a pC value, CIGRE TF 15/33.03.05 has recommended a method for its sensitivity verification which can be used to determine on-site the minimum sensitivity of this measuring method in GIS [11]. The sensitivity test will show the amount of PD which can be measured by the electromagnetic method. The sensitivity of the electromagnetic method is very dependent on the type of sensor, types of PD source and the surrounding structure [17].

2.1. UHF Electromagnetic Signal

The electromagnetic pulses generated by the PD source can carry a wide band frequency signal depending on their rise time. In air, the propagation velocity of the electromagnetic signals is approximately as fast as the speed of light (c). In other media, the speed of the electromagnetic signal (v) depends on the permittivity and permeability of the material. This factor is called the refractive index of the material and is expressed as:

$$\eta = \frac{c}{v} = \sqrt{\frac{\mu\varepsilon}{\mu_0\varepsilon_0}} = \sqrt{\mu_r\varepsilon_r} \quad 1$$

where $\varepsilon = \varepsilon_r\varepsilon_0$ is the permittivity of the material, and $\mu = \mu_r\mu_0$ is the permeability of the material (expressed as a product of its relative value and the absolute value of free space). In a vacuum, the propagation velocity of electromagnetic signals is the speed of light, i.e. 3×10^8 m/s.

2.2. Sensor sensitivity

The placement of the UHF sensors to detect PD events in transformers is usually at fixed locations. The locations of sensor installation depend on the type of sensor and transformer construction, as described in a previous section. As the PD can occur in any location in the transformer, the electromagnetic signal path from the PD source to the sensor can be affected by the structure inside the transformer. The signal path is also affected by the density of the insulation oil in the transformer tank which can also be subjected to variations in temperature (caused by loading changes). In addition, the live active parts of the transformer can obstruct electromagnetic signals and cause signal attenuation whereby the signal becomes not linear to the distance. This will cause conversion of the signal magnitude detected by the UHF sensor to an equivalent pC level to become difficult [10].

CIGRÉ WC TF 15/33.03.05 [11] recommended sensitivity verification for UHF method as a substitution for calibration. Sensitivity verification can be used on-site to determine the minimum sensitivity of the measuring system. Although this recommendation is only for GIS, with some adjustment this method can also be applied to power transformers which use oil insulation. The sensitivity of the UHF measuring method is very dependent on the type of sensor, on the type of the PD defect, and on the location of the PD source [17].

3. Transverse electromagnetic cell (TEM cell)

TEM cell is used to provide a testing chamber for electrical apparatus, whenever the testing procedure requires uniform electromagnetic around the testing sample. Also, the TEM cell, provide barrier from unwanted electromagnetic signals that probably obstruct measuring results.

The basic TEM cell consists of a parallel conductor plate as shown in Figure 1. One conductor is wider and connected to ground. The top conductor with specific widths is arranged with specific distance to produce desire impedance. In this paper, discussed the TEM cell with impedance 50 Ohms. The parallel conductor TEM cell as shown in figure 1 is the simplest form of the TEM cell. This type has disadvantage due to the presence of unwanted (noise) signals.

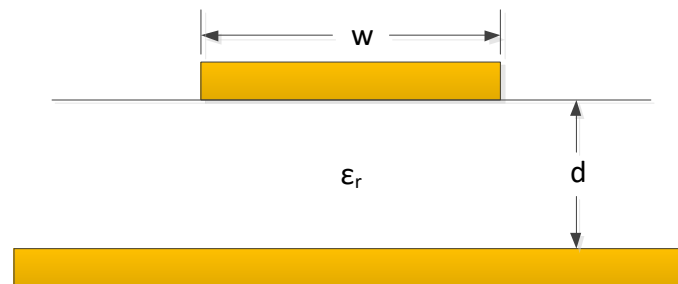

Figure 1: Cross section of a parallel conductor of TEM cell.

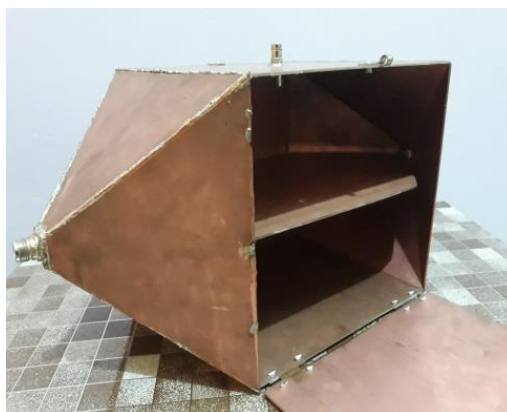

Figure 2. Closed type TEM cell use to test sensor sensitivity.

To overcome the open type TEM cell disadvantage, a close type TEM cell is used in this paper. The close type TEM cell used in this paper is shown in figure 2. The TEM cell built using a dual layer PCB.

4. Result and discussion

The experiment setup diagram is shown in Figure 3 and arrangement is shown in Figure 4. The step pulse input signals produce by a function generator. Step pulse input connected to one port of the TEM cell. A dual channels oscilloscope is used to record the step pulse on the input port and the sensor output. The other end port of the TEM is connected to a 50-ohm termination. Two type of sensors use in experiment i.e. monopole and a planar-spectral sensor. The Monopole sensor has 5 cm length and the spectral sensors have two size, that is 5 cm and 10 cm wide.

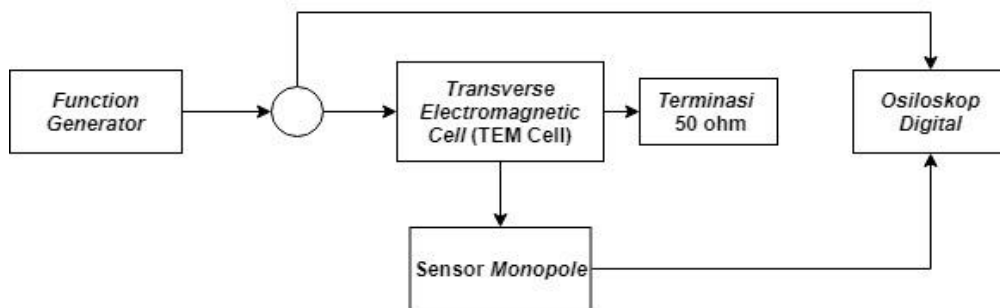

Figure 3. Block diagram sensor sensitivity test.

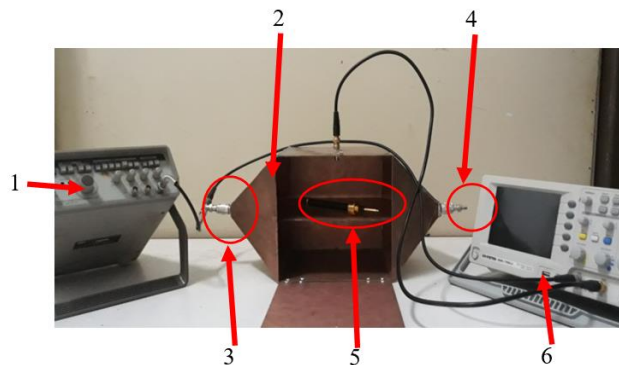

Figure 4. Sensitivity test of the electromagnetic sensor using TEM cell.

1. Function generator, 2. Transverse electromagnetic (TEM) cell, 3. T BNC connector, 4. A 50-ohm termination, 5. Monopole or spectral sensor and 6. Oscilloscope

The sensor signal responses for each type of sensors are shown in Figure 5. The step pulse input shown in red color and the sensor response in blue color. The three sensors have quite similar response, with fast oscillation after the step input signal hit the TEM cell input port. The time delay between the step input signals and the sensors output seems undetectable. This might due to the length of the TEM is quite small. Thus, the time needed by the step pulse signals from the input port to reach the other end port is almost instantaneous.

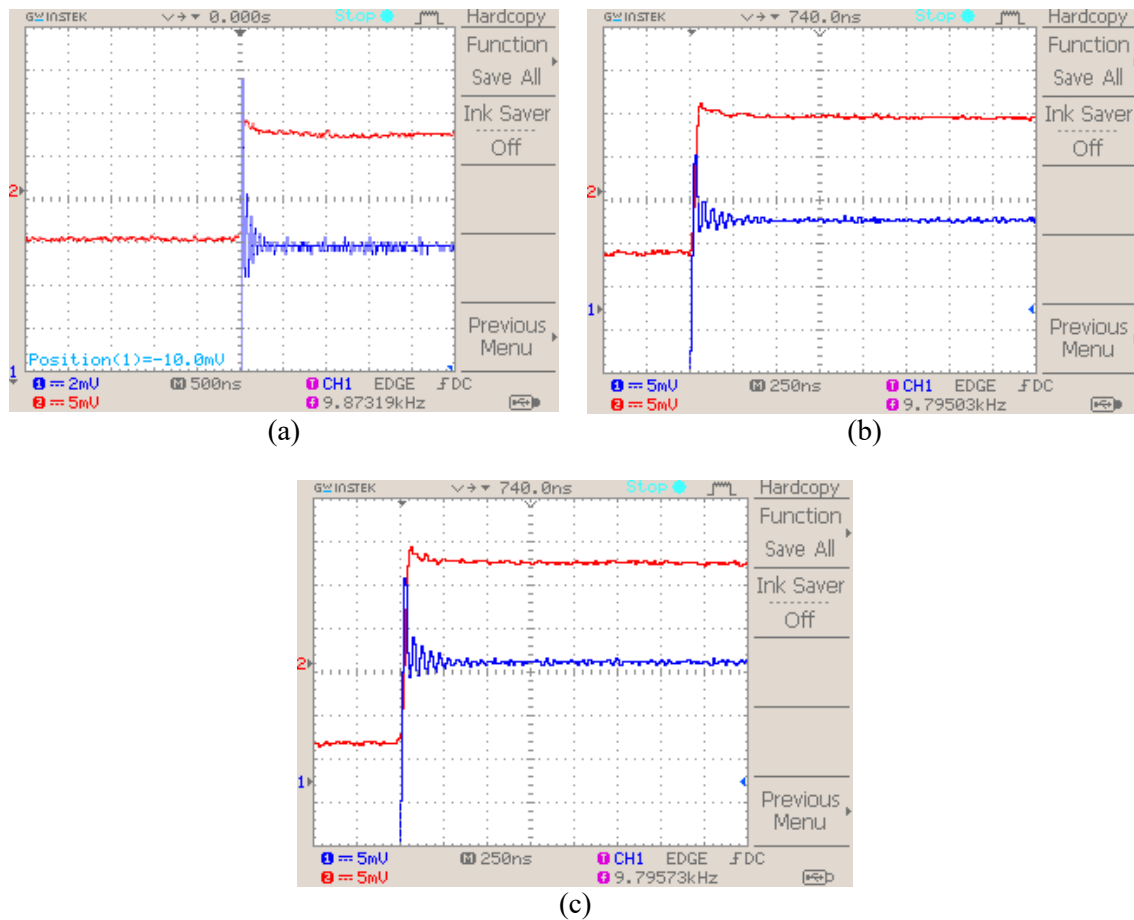

Figure 5. Typical sensor response (a) monopole (b) fractal 5 cm (c) fractal 10 cm.

Of the three sensors, all sensor has ability to response to the step pulse signals. The fractal sensor with size 10 cm has higher signals response as it has bigger dimension compare to monopole and 5 cm spectral sensor. The monopole has lower waveform magnitude and longer oscillation. Nevertheless, the three sensors have sensitivity to detect the step pulse thus should be able to detect electromagnetic signals generated by a PD source.

5. Conclusion

The experiment result shows the TEM cell can be used to test the sensitivity of the electromagnetic sensor. Two types of sensor are tested in this paper, i.e. monopole and spectral sensor. The two types sensor show different sensitivity, with spectral sensor has highest sensitivity. The larger the spectral sensor size, the higher its sensitivity. The sensitivity test using TEM cell provide data about the sensor ability to detect the electromagnetic signal, thus should be able to detect the electromagnetic signals generated by a partial discharge source. Further research is to compare the sensitivity test results to the ability of the sensor to detect electromagnetic signals produce by partial discharge events. The sensor ability to detect the signals in wide frequency bandwidth should be studied. The frequency range of the sensor works can be measure using a spectrum analyzer. Input to the TEM cell also need to modify so the input signals contain a wide band.

Acknowledgements

The authors would like to express their gratitude to Kemenristek-DIKTI Indonesia for supporting this research. This research was supported by Kemenristek-DIKTI Indonesia with the Fundamental Research Grant, contract number: 857/UN26.21/PN/2019.

References

- [1] Judd M D, Yang L and Hunter I B B 2005 *IEEE Electrical Insulation Magazine* **21** 2 pp 5-14.
- [2] Judd M D, Yang L and Hunter I B B 2005 *IEEE Electrical Insulation Magazine* **21** 3 pp 5-13.
- [3] Judd M D, Cleary G P, Bennoch C J, Pearson J S and Breckenridge T 2002 *Electrical Insulation Conference Record of the IEEE Int. Symp. on Electrical Insulation* pp 145-149.
- [4] Sinaga H H, Phung B T and Blackburn T R 2009 *19th Australasian Universities Power Engineering Conference (AUPEC'09)* paper PP027.
- [5] Sinaga H H, Phung B T and Blackburn T R 2012 *Int. Conf. on Condition Monitoring and Diagnosis (CMD2012)*
- [6] Wenger P, Beltle M, Tenbohlen S, Riechert U, Behrmann G 2019 *IEEE Transactions on Power Delivery*, **34** 4 pp 1540 - 1548
- [7] Bin F, Wang F, Sun Q, Lin S, Xie Y, Fan M 2018 *IET Microwaves, Antennas & Propagation* **12** 14 pp 2184 - 2190
- [8] Stone G C 2005 *IEEE Transactions on Dielectrics and Electrical Insulation* **12** 5 pp 891-903
- [9] Cavallini A, Montanari G C, Tozzi M 2010 *IEEE Transactions on Dielectrics and Electrical Insulation* **17** 1 pp: 198 – 205, 2010
- [10] Coenen S, Tenbohlen S, Markalous S M, Strehl T 2008 *IEEE Transactions on Dielectrics and Electrical Insulation* **15** 6 pp 1553 – 1558
- [11] CIGRE TF 15/33.03.05 1999 *Electra* **183** pp 75-87
- [12] Judd M D and Farish O 1998 *IEEE Transactions on Instrumentation and Measurement* **47** 4 pp 875-880
- [13] Kang N W, Kang J S, Kim D C and Kim J H 2007 *IEEE Transactions on Instrumentation and Measurement* **56** 2 pp 435-438
- [14] Judd M D 1999 *IEEE Proceedings-Science, Measurement and Technology* **146** 3 pp 113-116
- [15] Ishigami S and Hirata M 2009 *Proc. 20th Int. Zurich Symposium on EMC* pp 425-428
- [16] Judd M D, Farish O and Pearson J S 1997 *IEE Proceedings - Science, Measurement and Technology* **144** 3 pp 117 - 122
- [17] Sinaga H H, Phung B T, Ao A P and Blackburn T R 2011 *XVII Int. Symp. on High Voltage Engineering Paper D-069*.