

Development of Testing Equipment of Hydrokinetic Turbine Model to Support Implementation of the Laboratory Work

Jorfri Boike Sinaga ^{a*}, Novri Tanti ^b and M. Dyan Susiala ^c

Mechanical Engineering Department, Faculty of Engineering, University of Lampung, Province of Lampung, Indonesia

^ajorfri6@yahoo.com, ^bNovri_t@unila.ac.id, ^cmdyan.susila@eng.unila.ac.id

Abstract

Mechanical Engineering Department, University of Lampung has been established since 1998 and in the implementation of learning process at this department supported by ten laboratories, that is: Laboratory of CNC, Laboratory of Drafting, Laboratory of Materials, Laboratory of Manufactured, Laboratory of Computer, Laboratory of Industry Metrology, Laboratory of Structural Mechanics, Laboratory of Thermodynamics, Laboratory of Fluid Mechanics, and Laboratory of Combustion Engine. These laboratories are used as research means for the lecturers and the students and also for the implementation of the subject of available laboratory work in the curriculum of Mechanical Engineering Department, University of Lampung, One of the subjects of laboratory work is machine performance, where this laboratory work is carried out in three laboratories, that is Laboratory of Thermodynamics, Laboratory of Fluid mechanics, and Laboratory of Combustion Engine. The testing equipments are available until now, namely, vapour compression refrigeration system, Pelton turbine, and combustion engine, and these testing equipments need for the addition to support this laboratory work. However the funding from university is very limited. Therefore addition testing equipment must be made. In this paper design of a testing equipment of ultra low head hydraulic turbine model is presented to be used for laboratory work of machine performance in Mechanical Engineering Department, University of Lampung.

Keywords: Hydraulic Turbine, Hydrokinetic Turbine, Laboratory Work, Machine Performance

1. Introduction

The learning process carry out at the Mechanical Engineering Department of Faculty of Engineering, University of Lampung is currently supported by 10 laboratories, namely: Laboratory of CNC, Laboratory of Drafting, Laboratory of Materials, Laboratory of Manufactured, Laboratory of Computer, Laboratory of Industry Metrology, Laboratory of Structural Mechanics, Laboratory of Thermodynamics, Laboratory of Fluid Mechanics, and Laboratory of Combustion Engine. These laboratories are used as research facilities for lecturers and students and also for the implementation of laboratory work

courses in the curriculum of the Department of Mechanical Engineering, Faculty of Engineering, University of Lampung. One of the laboratory work courses is the laboratory work of machine performance. This laboratory work is carried out so that students are able to determine and measure the performance parameters of energy conversion machines by applying theories that have been obtained in the courses of Fluid Mechanics, Thermodynamics, and Energy Conversion Machines. However, the testing equipment to carry out the laboratory work of machine performance is still lacking, where the testing equipments are available until now, combustion engine, Pelton turbine and Air Conditioning (AC). This is caused by the limited funds provided by the university to supply the testing equipment in the laboratory. So it is necessary to develop additional testing equipment to support the implementation of this laboratory work. In this paper is given the design and development of testing equipment of ultra low head hydraulic turbine model to support implementation the laboratory work of machine performance in Mechanical Engineering Department, University of Lampung.

For decades scientists have tried to use conventional turbines for low flow heads. Highly efficient water turbines for high flow heads are very expensive when applied to hydropower stations with low or very low heads. The main types of water turbines currently used to harness hydropower are: Kaplan, Francis, Pelton, and cross flow turbines. The Kaplan turbine is one of the water turbines which technically can be used for a two meter head height or a lower water head but the turbine operating unit cost increases up to about four times when the water heads fall from 5 to 2 meters.

In 1931 Darrieus patented reaction turbine to use low or very low head flow energy (free flow). This turbine has a drum-like shape with a number of straight or curved blades of airfoil and a shaft that is perpendicular to the fluid flow. This turbine allows high torque for slow current flow, and provides a large fluid flow through the turbine without enlarging the diameter.

An approximation of the vertical axis turbine is used to calculate the power was generated by this hydrokinetic turbine blade, as can be seen in Figure 1. The resultant velocity vector (\vec{W}) is the sum of the velocity vector of fluid (\vec{V}) and the velocity vector of the advancing blade (\vec{U}).

$$\vec{W} = \vec{V} + (-\vec{\omega} \times \vec{R}) \quad (1)$$

where R is the radius of turbine (m), and ω is the angular velocity of turbine (rad/ s). From the Figure 1, the resulting of fluid velocity varies, the maximum is found for $\theta = 0^\circ$ and the minimum is found for $\theta = 180^\circ$, where θ is the azimuthal or orbital blade position. The angle of attack α is the angle between the resultant vector velocity (\vec{W}), and

blade's chord. From geometrical considerations, the resultant of flow velocity and the angle of attack are calculated as follows:

$$W = V \sqrt{1 + \lambda^2 \cos^2 \theta} \quad (2)$$

$$\alpha = \tan^{-1} \left(\frac{\lambda \sin \theta}{1 + \lambda^2 \cos^2 \theta} \right) \quad (3)$$

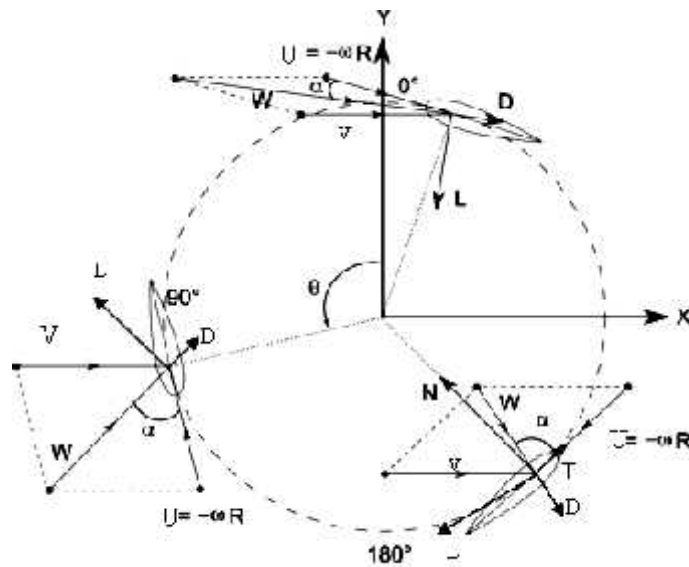

Figure 1. Forces and velocities acting in a vertical axis wind turbine for various azimuthal positions.

where λ is tip speed ratio, and α can be calculated by using the following equation

$$\alpha = \tan^{-1} \left(\frac{\lambda \sin \theta}{1 + \lambda^2 \cos^2 \theta} \right) \quad (4)$$

The resultant aerodynamic force is composed in the lift force (F_L) and drag force (F_d) which these forces can be calculated using the following equation:

$$F_d = \frac{1}{2} C_d \rho V^2 A \quad (5)$$

$$F_L = \frac{1}{2} C_l \rho V^2 A \quad (6)$$

where C_d is the coefficient of drag, C_l is the lift coefficient, ρ is fluid density (kg/m^3), V is fluid velocity (m/s), and A is cross-sectional area of the hydro foil blade (m^2).

The force perpendicular to the arm (radius) of turbine, the torque by projecting lift and drag forces can be calculated using the following equation:

$$T = (F_l \cdot \sin r - F_d \cdot \cos r) \times R \quad (7)$$

where T is the torque (N.m), F is the force perpendicular to the arm (N), and R is the radius (m). From Equation 7, the shaft power P_b (W) can be calculated using the equation:

$$P_b = T\tilde{\omega} \quad (8)$$

2. Materials and Methods

2.1 Determining the Turbine Parameters

The model of designed turbine to be used in the testing equipment is shown in Figure 4. The parameters of turbine to be determined: height of turbine L, diameter of turbine R, shape of blade, and number of blades n.

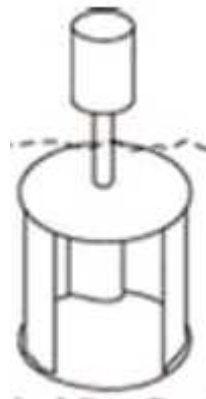

Figure 2. Scheme of hydrokinetic turbines model

Determining dimensions of the testing equipment system and the parameters of the hydrokinetic turbine to be used should consider the Fluid Mechanics Laboratory conditions and the available measurement instruments. The measurement instruments used to execute this laboratory experiment are torque meter to measure the torque produced by shaft turbine (N.cm), with the maximum torque meter of 147 N.cm, tachometer to measure the speed of turbine rotation (rpm) and propeller flow meter to measure the velocity of flow (m/s).

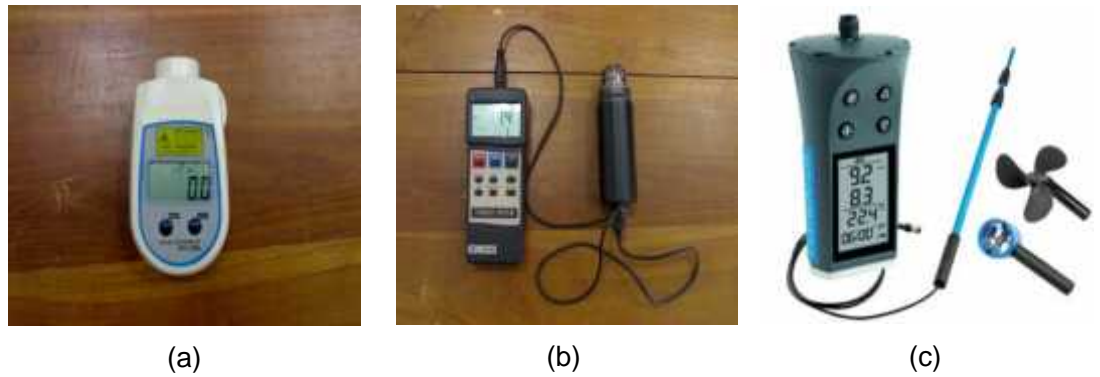

Figure 3. Photograph of measurement instruments: a. tachometer, b. torque meter, and c. propeller flow meter

2.2. Construction of Testing Equipment

Scheme of the testing equipment design can be seen in Figure 6. This device transforms kinetic energy derived from flow of low head, to turn a turbine to produce mechanical energy of rotation and whose primary function is to drive an electric generator.

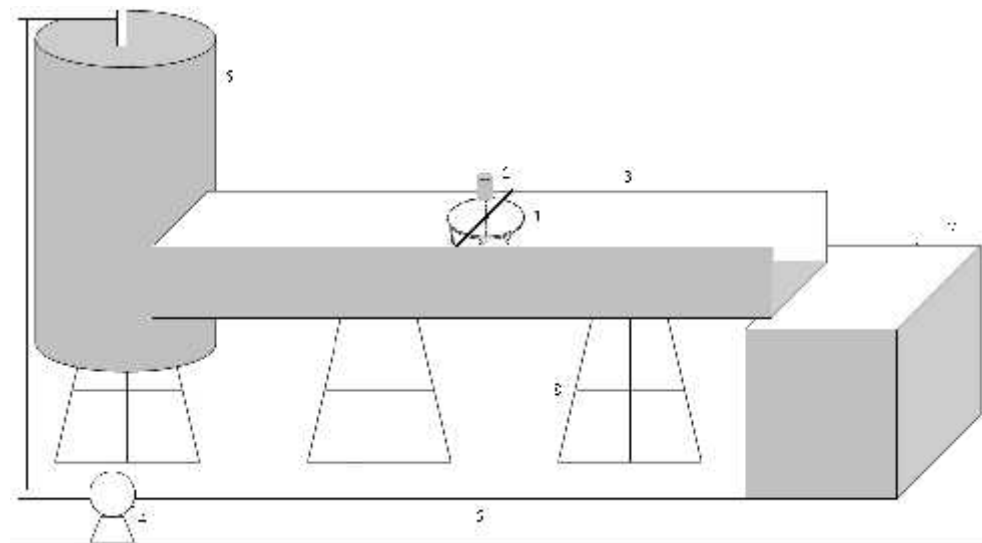

Figure 4. Schematic of testing equipment system

Caption:

- | | |
|-------------------------|---------------------------------|
| 1. Hydrokinetic turbine | 2. Torque meter |
| 3. Channel | 4. Pump |
| 5. Pipe | 6. Tank |
| 7. Reservoir | 8. Testing equipment supporting |

The efficiency η_t of hydrokinetic turbine model can be calculated using the equation:

$$\eta_{sys} = \frac{P_t}{0,5 \cdot \rho \cdot A_t \cdot V^3} \quad (9)$$

Where P_t is power generated by turbine shaft (W), it can be calculated using the Equation 7, ρ is water density (kg/m^3), V is velocity of water flow (m/s), and A_t is cross sectional area of hydrokinetic turbine (m^2).

3. Results and discussion.

3.1. Model of Testing Equipment System

According to the conditions of space of the Fluid Mechanics Laboratory, dimensions of tank and cross-sectional area of channel were determined 1 m x 1 m x 1 m and 20 cm x 30 cm respectively. The available head of flow is 1 m to run the experiment. The velocity of flow in channel was measured by propeller flow meter and it can be varied to 1.37 m/s, 1.56 m/s and 2.1 m/s.



Figure 5. System of testing equipment

3.2. Turbine Design

Generally hydrokinetic turbine uses blade's airfoil, due to its high efficiency and produces a large pressure difference between two sides of blade to rotate with a

considerable force moment in which the force moment is generated by lift and drag force. The lift and drag forces that occur in the airfoil sections are influenced by the shape of blade and the angle of attack. The symmetry airfoils of RISØ-A [3] was used for the turbine blades.

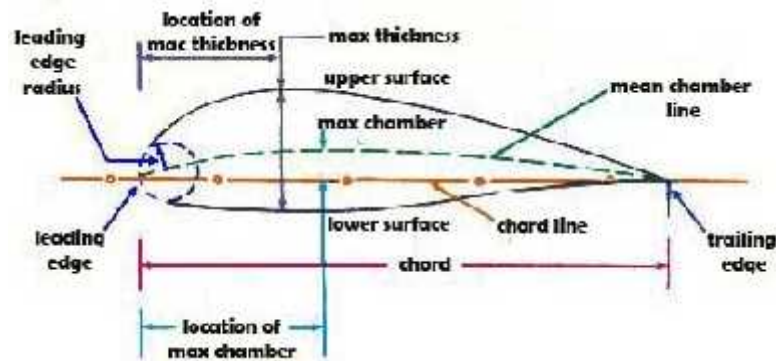

Figure 6. Parameters of NACA airfoil

According to conditions of the channel, hydrokinetic turbine to be used has 10 cm in diameter and 20 cm in height.

The performance of hydrokinetic turbine operation is also influenced by relative solidity. Figure 7 [5] is shown the effect of tip speed ratio to coefficient of performance C_p (efficiency) for each relative solidity of hydrokinetic turbine (HKT) Darrieus with straight blade.

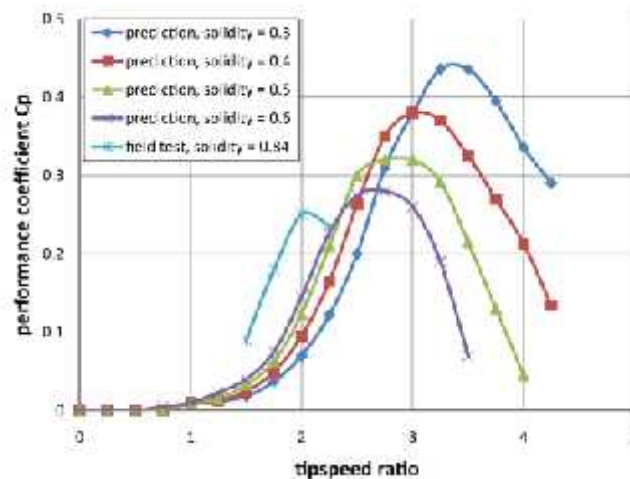

Figure 7. Predicted and measured performance of Darrieus HKTs of varying solidity

The tip speed ratio of turbine operation was determined $\lambda = 3$ [4], this is to prevent cavitation during turbine operation. From Figure 10, for tip speed ratio $\lambda = 3$, it was obtained the relative solidity $\sigma = 0.4$ as proposed by Shiono et. al.[6]. Based on previous study [7], operating the helical turbine with tree blades was given the maximum

efficiency. Using Equation of 14 and 15, it was found the length of chord's blade of 4.2 cm.



Figure 8. Model of hydrokinetic turbine with three blades

3.4. Testing Results and Discussion

Figure 10 are given the testing results of the testing equipment of hydrokinetic turbine. From the testing results in Figure 13, the turbine using 3 number of blades give the highest efficiency and shaft power, where these values of efficiency and power were found 28.03 % and 9.46 W respectively. It was better as compare with the using 2 number of blades of turbine. This is due to the operation of turbine using 3 blades produced greater lift forces compared with the 2 number of blades. The best operation of this turbine was at the tip speed ratio of 0.89.



Figure 9. Testing of the developed testing equipment

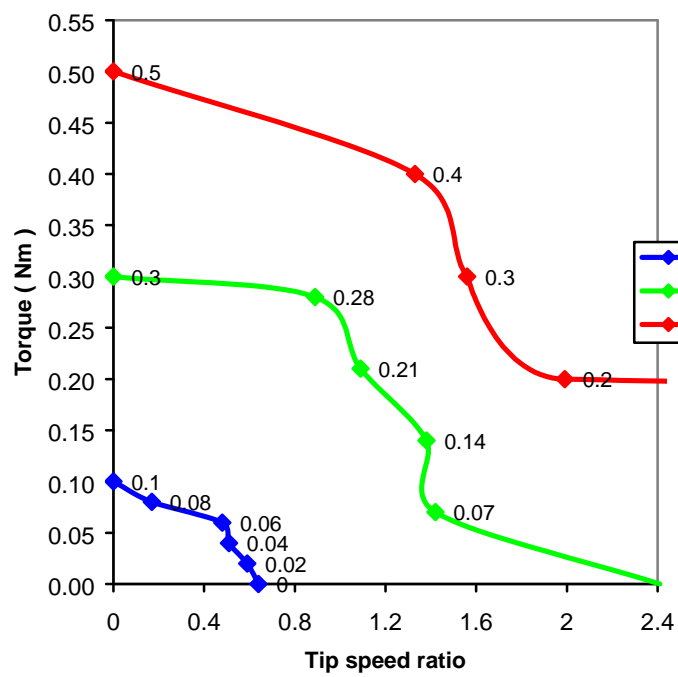

a. Influence of volume flow rate on the torque

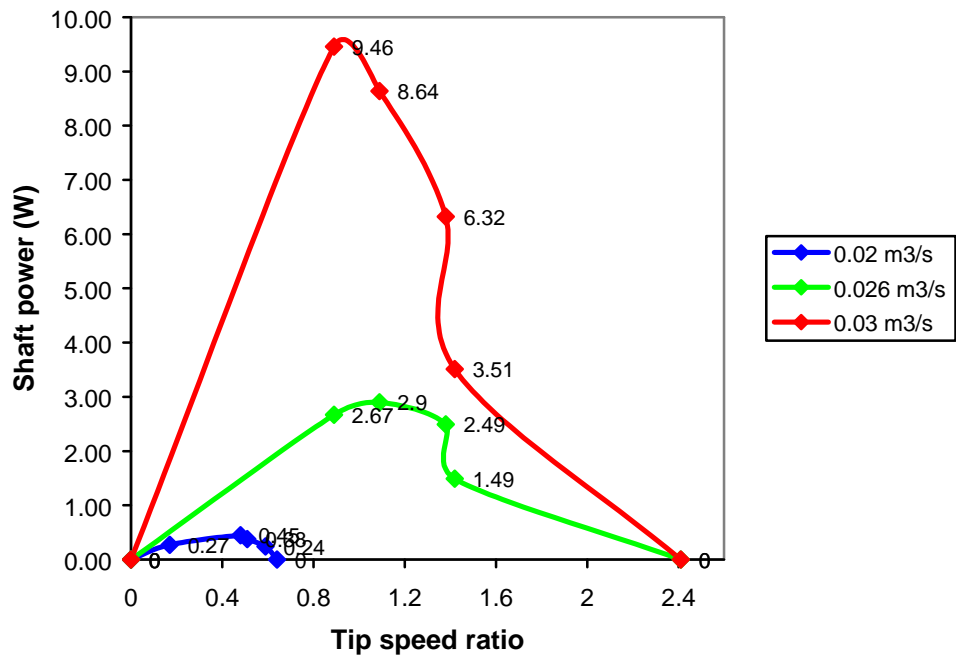

b. Influence of volume flow rate on the shaft power

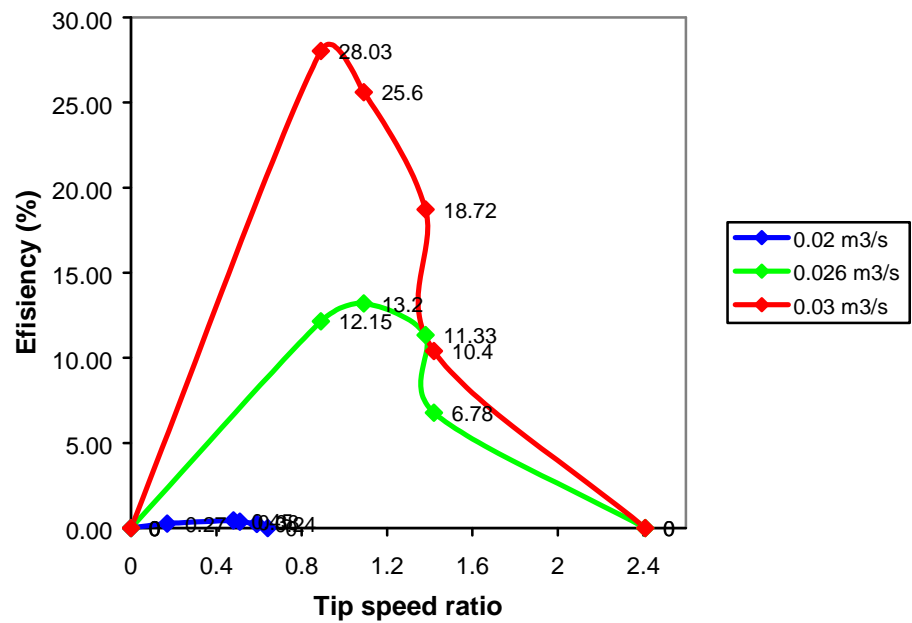

c. Influence of volume flow rate on the efficiency

Figure 10. The testing results of hydrokinetic turbine model with using 3 number of blades

The developed testing equipment of hydraulic kinetic turbine model can perform the performance characteristics of hydrokinetic turbine. Using this testing equipment will help the students to understand how the working principle of hydrokinetic turbine to convert kinetic energy of water flow into mechanical energy. The testing results show how the velocity of flow influence the performance characteristics of hydrokinetic turbine. Therefore this testing equipment of hydrokinetic turbine model can be used to support implementation the laboratory work of machine performance in Mechanical Engineering Department. This testing equipment will also help the students who interested in studying the performance of this turbine when it is applied in the system of hydro electric power generation to utilize kinetic energy derived from flow of low head or stream of water.

4. Conclusions

Based on the results that have been obtained and described earlier, it can be taken some conclusions:

1. In this research is given design method of the testing equipment of hydrokinetic turbine model to support implementation the laboratory work in Mechanical Engineering Department.
2. The developed testing equipment of hydrokinetic turbine model can perform the performance characteristics of hydrokinetic turbine to utilize the stream flow energy which has very low head or only kinetic energy.
3. The test results show how the velocity of flow influence the performance characteristics of hydrokinetic turbine where using 3 number of blades gives the maximum of turbine efficiency of 28.03 %.
4. The course of this laboratory work will provide an opportunity for students to develop their competency in design and execution of laboratory experiments, analysis and interpretation of data use information from the engineering literature including basic concepts from the courses have introduced by the lecturer especially fluid mechanics, energy conversation and fluid machinery subject.

Acknowledgment

This research work was supported by Penelitian Unggulan Grant 2019, University of Lampung. The authors would like to acknowledge the financial support from LPPM University of Lampung.

References

- [1] Alexander G 2008 Development of The Hydrokinetic turbineal Reaction Turbine. Final Technical Report (DE-GO1-96EE15669)
- [2] Jorfri B S, Ahmad S, Aang K, Milia R, and Sugiman, 2017 Perancangan Alat Pengujian Model Turbin Air *Ultra Low Head* untuk Sistem Pembangkit Listrik Tenaga Mikro Hidro (PLTMH), Prosiding Seminar Nasional Energi dan Industri Manufaktur 2017, Universitas Lampung, Bandar Lampung
- [3] Andareas W S, Jorfri B S, and Agus S, 2014 Kajian Eksperimental Pengaruh Bentuk Sudu terhadap Unjuk Kerja Turbin Helik untuk Model Sistem Pembangkit Listrik Tenaga Mikro Hidro (PLTMH), Jurnal FEMA, Jurusan Teknik Mesin Universitas Lampung, 2 pp 72–78
- [4] Alexander G 2010 Hydrokinetic turbineal Turbine and Fish Safety Available: www.mainetidalpower.com/files/gorlovrevised.pdf. Accesed on April 22, 2015
- [5] B K Kirke, 2011 *Renewable Energy*. 36: 3013-3022
- [6] Shiono, M., Kdsuyuki S, and Sezji, K. 2002. Output Characteristics of Darrieus Water Turbine with Hydrokinetic turbineal Blades for Tidal Current Generations. Proceedings of The Twelfth (2002) International Offshore and Polar Engineering Conference Kitakyushu, Japan, May 26 2002
- [7] Dwi S 2016 Kajian Eksperimental Pengaruh Jumlah Sudu terhadap Unjuk Kerja Turbin Helik untuk Sistem Pembangkit Listrik Tenaga Mikro Hidro (PLTMH). Tugas Akhir Mahasiswa, Jurusan Teknik Mesin, Universitas Lampung

**Tarumanagara International Conference
on the Applications of Technology and Engineering 2019**

CERTIFICATE

OF ACHIEVEMENT

this certificate is presented to

Jorfri Boike Sinaga

*for the contribution as **Presenter***

Paper Title: Development of Testing Equipment of Hydrokinetic Turbine Model to Support Implementation of the Laboratory Work

November 21st - 22nd. 2019

Universitas Tarumanagara, Jakarta

Chairman



TICATE

Dr. Hugeng, S.T., M.T.

Rector



REKTOR

Prof. Dr. Agustinus Purna Irawan