



Slow release urea fertilizer synthesized through recrystallization of urea incorporating natural bentonite using various binders

Lilis Hermida*, Joni Agustian

Department of Chemical Engineering, Universitas Lampung, Bandar Lampung 35145, Lampung, Indonesia



HIGHLIGHTS

- Various binders were used for syntheses of slow release urea fertilizers (SRUFs).
- SRUFs using corn starch binder released more slowly urea than those using HPMC.
- SRUFs released urea through anomalous transport or Fickian release mechanisms.
- Hydrogen bonds, electrostatic and Van der Waals force were detected in the SRUFs.

GRAPHICAL ABSTRACT

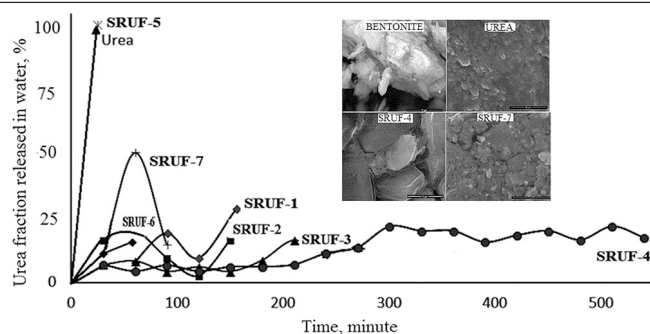

ARTICLE INFO

Article history:

Received 30 July 2018

Received in revised form 24 November 2018

Accepted 24 November 2018

Available online 28 November 2018

Keywords:

Natural bentonite

Slow release urea fertilizer

Corn starch

Hydroxypropyl methylcellulose

Release mode

ABSTRACT

In this study, various slow release urea fertilizers (SRUFs) were prepared by incorporation of urea into local natural bentonite with various binder i.e. corn starch and hydroxypropyl methylcellulose (HPMC). In the preparation, a binder was added to a mixture of natural bentonite and melted urea. Then, the admixture was put into a mould and extruded to obtain SRUF in the form of pellets. The SRUF was dried at 50 °C for 8 h before use. Urea desorption mechanisms of the SRUF was examined through static release experiments. The structural properties of SRUF was characterized through scanning electron microscopy with energy dispersive x-ray (SEM-EDX) analysis and Fourier-transform infrared spectroscopy (FTIR). It was found from static release experiments that the SRUFs more slowly released urea in water than conventional urea fertilizer. After 500 min of the experiment, the slowest release of urea was achieved by SRUF using corn starch. Meanwhile, conventional urea fertilizer completely released urea in water after less than 50 min. Release mechanisms of the SRUF using corn starch and SRUF using HPMC were anomalous transport and Fickian diffusion, respectively.

© 2018 Elsevier B.V. All rights reserved.

* Corresponding author.

E-mail address: lilis.hermida@eng.unila.ac.id (L. Hermida).

1. Introduction

Urea ($\text{CO}(\text{NH}_2)_2$) is one of conventional fertilizers, which is commonly used in agriculture. Urea contains nitrogen that is absorbed by plants in the form of ammonium (NH_4^+) and nitrate (NO_3^-) (Hirel et al., 2011; Schjorring, 1986). When urea comes in contact with soil in the presence of moisture, urease enzyme in soil converts nitrogen in urea into ammonium (NH_4^+) through hydrolysis process. Then, the ammonium is converted into nitrite (NO_2^-) and followed by the oxidation of the nitrite (NO_2^-) to nitrate (NO_3^-) by enzymes through nitrification process. However, nitrogen in urea is absorbed only 25% up to 50% by plants since the nitrogen can be lost from soil because of nitrate (NO_3^-) leaching if soil cannot hold urea due to much incoming water from rain or irrigation (Chien et al., 2016; Dobermann et al., 2003). The nitrogen in urea can also be lost either through complete denitrification of nitrate (NO_3^-) producing nitrogen gas (N_2) or through incomplete denitrification of nitrate (NO_3^-) producing nitric oxide gas (NO) and nitrous oxide gas (N_2O), which volatilizes from the soil (Signor and Cerri, 2013).

Nitrate (NO_3^-), nitric oxide gas (NO) and nitrous oxide (N_2O) contribute to environmental problems. Nitrate (NO_3^-) is considered hazardous and leads to water pollution (Katan, 2009). Excessive nitrate concentrations in drinking water can be harmful to health, especially for infants and pregnant women. Meanwhile, it was reported that nitrous oxide (N_2O) has now become the largest ozone-depleting substance emitted in the 21st century (Ravishankara et al., 2009). The main source of N_2O emissions worldwide comes from nitrogen-based fertilizers. The presence of N_2O in the lowest region of the atmosphere (troposphere) can cause greenhouse effect or global heating since N_2O captures reradiated infrared radiation from the Earth's surface and subsequently warms the atmosphere. Besides that, N_2O can migrate up to the stratosphere where N_2O reacts with oxygen atoms to produce some nitric oxide (NO). Then, depleting of ozone layer occurs as NO reacts with stratosphere ozone (O_3) to form NO_2 and O_2 . Subsequently, NO_2 reacts with O to re-forms NO. Depleting of ozone layer increases UV rays from sun reaching the earth's surface. Excessive exposure to UV rays may cause skin cancer and eye damage.

In order to reduce the loss of nitrogen and to conserve and protect our environment, researchers developed slow-release urea fertilizer (SRUF). SRUF offers many potential benefits for plant as it provides a longer duration of nitrogen release than conventional urea fertilizer (Landschoot, 2015). Syntheses of SRUF consisting of urea coated in water-insoluble compounds such as sulphur, polyethylene, alkyl resin, polyurethane have been studied (Ali and Danafar, 2015; Salman, 1989). However, the coated urea had much longer release time (Xiaoyu et al., 2013). Besides that, the coating materials were difficult to degrade properly in soil solution phase (Ali and Danafar, 2015). As such, soil structure could be damaged due to accumulation of the coating materials.

SRUF with a three-dimensional lattice structure has been successfully synthesized (Xiaoyu et al., 2013; Lixiang et al., 2011; Zengming et al., 2008). It was found from static release experiment that urea in the SRUF released in water longer than conventional urea fertilizer. The SRUF was synthesized by melting urea and then mixing it with China natural bentonite as a substrate and organic polymer of polyacrylamide as a binder (Xiaoyu et al., 2013). However, effects of binder type on characteristics and release mechanisms of SRUF have not been reported so far. Therefore, in the present study, effects of binder type (i.e. corn starch and HPMC) on structural characteristics and release mechanisms of various SRUFs were investigated.

Bentonite is an inexpensive natural resource and abundantly available in Indonesia. Several provinces in Indonesia including Lampung has bentonite deposits (Rahardjo et al., 2011). Substrate that was used in this study was local natural bentonite (from Karawang village-Pringsewu, Lampung, Indonesia). Structural characteristics of the SRUFs were analysed using Fourier Transform Infrared (FT-IR), Scanning Electron Microscopy (SEM) and Energy dispersive X-ray (EDX) in conjunction with SEM. Static release experiments designed according to a procedure in the literature (Higuchi, 1963) were conducted to investigate release mechanisms and desorption rate models of SRUFs.

2. Material and methods

2.1. Material

Natural bentonite was taken from Karawang village-Pringsewu, Lampung, Indonesia. Chemical composition of the natural bentonite was analysed using by X-ray fluorescence spectroscopy and is listed in Table 1. The natural bentonite was treated using method reported in the literature (Xiaoyu et al., 2013) as follows: the bentonite was sieved through a 200 mesh screen. Subsequently, it was washed and dried at 105 °C before use. Corn starch (Maizenaku brand produced by EGAFood, Jakarta, and Indonesia), urea (produced by PUSRI fertilizer factory, Palembang, Indonesia) and hydroxypropyl methyl cellulose (Sigma-Aldrich) were dried at 80 °C for 8 h before used.

2.2. Preparation of slow-release urea fertilizers (SRUFs)

Preparation of various slow-release urea fertilizers (SRUFs) were carried out using procedure adapted from Xiaoyu et al. (2013) with modifications in terms of bentonite source, type of binder and composition of materials. In the preparation, 90 g of urea was melted on a hot plate at 130 °C. After that, bentonite (9.2–9.8 g) was added to the urea and mixed. Then the mixture was stirred for 5 min. Meanwhile, 3 mL of distilled water and a binder (0.2–0.8 g) were mixed and heated on a hot plate at 60 °C to obtain gel. Then the gel was added to a mixture of urea–bentonite and then evenly stirred. After that, the admixture was put into a mould and then extruded to obtain SRUF in the form of pellets. Subsequently, the SRUF was dried at 50 °C for 8 h before use. Different compositions of material used to prepare various SRUFs are summarized in Table 2.

Table 1
Chemical composition of local natural bentonite.

Component	% Component
SiO ₂	83.4
Al ₂ O ₃	11.5
Fe ₂ O ₃	2.1
MgO	0.22

Table 2
Compositions of material used to prepare various SRUFs.

SRUFs	Urea (g)	Bentonite (g)	Corn starch (g)	HPMC (g)
SRUF -1	90	9.8	0.2	–
SRUF-2	90	9.6	0.4	–
SRUF-3	90	9.4	0.6	–
SRUF-4	90	9.2	0.8	–
SRUF-5	90	9.2	–	0.2
SRUF-6	90	9.2	–	0.5
SRUF-7	90	9.2	–	0.8

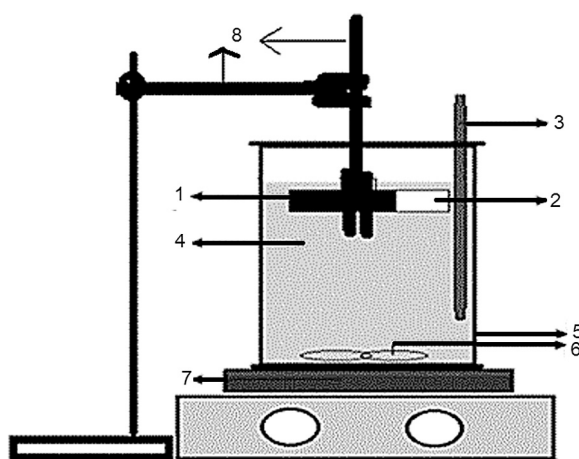

Fig. 1. Experimental set up for static release experiment (1 = fertilizer sample, 2 = pipe, 3 = thermometer, 4 = water, 5 = beaker glass, 6 = magnetic stirrer bar, 7 = hot plate magnetic stirrer, 8 = universal clamp).

2.3. Characterization

The morphology and elemental composition of the samples were analysed by means of scanning electron microscopy (Zeiss EVO field) equipped with Energy Dispersive X ray Spectroscopy (Oxford INCA X act). Prior to the analyses SRUFs, natural bentonite and conventional urea fertilizer were coated with high purity gold. FT-IR spectroscopy (Perkin Elmer) was used to identify chemical bond functional groups of the samples through their characteristic absorption of infrared radiation in vibration modes

2.4. Method for a static release experiment

A static release experiment that was adapted from Higuchi procedure (Higuchi, 1963) was carried out at room temperature (around 30 °C) to investigate release mechanism of SRUF. The SRUF was in the form of pellet with average size was 1 cm long with diameter of 1 cm. It was reported in the literature that the bigger the SRUF, the more release time it gains. So, SRUF needs more time for releasing urea (Shaviv et al., 2003; Thanh et al., 2014). Experimental set up for static release experiment is shown in Fig. 1. Experimental apparatus consist of sample pipe, magnetic stirring rod, beaker glass, hot plate-stirrer, clamp and thermometer. In the experiment, the amount of SRUF either using corn starch or HPMC for static release experiment was 6 g. This SRUF amount was put into a pipe having 7 cm long and 5 cm inside diameter with one end closed. Then, the pipe was placed horizontally in a beaker glass containing 500 mL of water to release urea from SRUF to the water. After that, the stirrer was switched on and set at 100 rpm. Then, 1 mL of the water was taken every 25 min at 3 different positions in a centre of the beaker glass to determine urea concentration. As a comparison, the static release experiment was also carried out for conventional urea fertilizer.

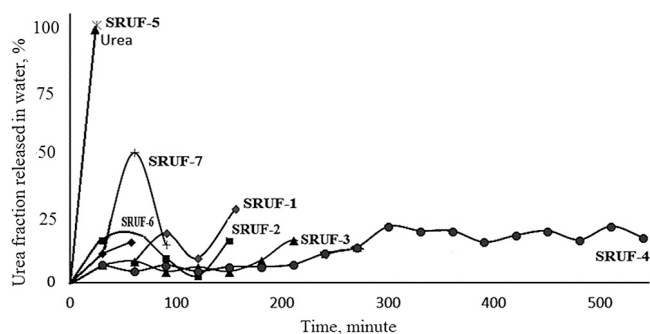

Fig. 2. Urea release behaviour for conventional urea fertilizer, slow release urea fertilizer using corn starch as binder (i.e. SRUF-1, SRUF-2, SRUF-3, SRUF-4) and slow release urea fertilizer using HPMC and binder (i.e. SRUF-5, SRUF-6, SRUF-7).

Determination of released urea was based on measuring absorbency of sample containing urea by using UV-vis spectrophotometer at wavelength of 440 nm. Firstly, calibration curve of absorption versus concentration was prepared to provide an equation. Subsequently, the absorption of the sample was measured and then, concentration of urea in the sample was calculated using the equation.

Type of urea release kinetics from SRUFs were determined by Peppas equation (Li et al., 2016):

$$Q_t = kt^n \quad (1)$$

where:

Q_t = a fraction of urea released in water at time t (%), or

$Q_t = \frac{\text{the amount of urea released at time } t \text{ (g)}}{\text{the total amount of urea released when the fertilizer dosage form is exhausted (g)}}$

k = the kinetic constant, (m^{-1})

t = time of urea release (m)

n = the diffusion exponent

Value of the diffusion exponent, n , indicates the urea release mechanism (Dash et al., 2010). The exponent $n \leq 0.5$ are for Fickian diffusion release from slab (non swellable matrix). $0.5 < n < 1.0$ are for non-Fickian release (anomalous) meaning that release follow both diffusion and erosion controlled mechanisms. $n = 1$ are for zero order release, where drug release is independent of time (Korsmeyer and Peppas, 1984; Singh et al., 2011). Also, $0.45 < n < 1.0$ for non-Fickian release (anomalous) from cylinders (non swellable matrix) and $0.43 < n < 1.0$ for non-Fickian release (anomalous) from non swellable spherical samples.

3. Results and discussion

3.1. Effect of binder types and their compositions on urea release behaviour of slow-release urea fertilizers (SRUFs)

Fig. 2 shows urea release behaviours for conventional urea granule, slow-release urea fertilizers synthesized by urea-incorporated bentonite with corn starch as binder (i.e. SRUF-1, SRUF-2, SRUF-3, SRUF-4) and slow-release urea fertilizers synthesized by urea-incorporated bentonite with hydroxypropyl methylcellulose (HPMC) as binder (i.e., SRUF-5, SRUF-6, SRUF-7) at specified time interval through static release experiments. As can be seen from the figure, urea completely dissolved in water after less than 50 min for conventional urea granule. In general, SRUFs synthesized by urea-incorporated bentonite with corn starch as binder had longer release times than those with HPMC as binder. These results indicated that binder types strongly affected on urea release behaviour of SRUFs. The longer release times of SRUFs using corn starch as binder in their preparations could be due to the more hydrophobicity of corn starch. Meanwhile, HPMC is a hydrophilic polymer and a water soluble compound (Timmins et al., 2014).

Furthermore, urea release times increased when the amounts of binder were increased as shown in Fig. 2. The main factor slowing down the urea release time was bentonite network structures that made path length for the water penetration increase (Xiaoyu et al., 2013). It was stated in percolation theory that a material release was derived by dissolution of the material through capillaries composed of interconnecting the material particle cluster and pore network (Holman and Leuenberger, 1988). Besides, interaction between bentonite and binder resulted in aggregation leading to decreases in bentonite porosity (Kamalakar et al., 2011). So that the more binder materials were used, the fewer pore networks were generated (Ali et al., 2014). Therefore, urea release time of SRUFs increased with the increase in binder amount. It can be noted that SRUF-4 using the highest amount of corn starch (i.e. 0.8 g) had the longest urea release time. Only about 10% urea released in 200 min for SRUF-4 meanwhile SRUF-3 released 20% urea in the same release time. SRUF-1 and SRUF-2 released 30% and 20% urea, respectively in 150 min.

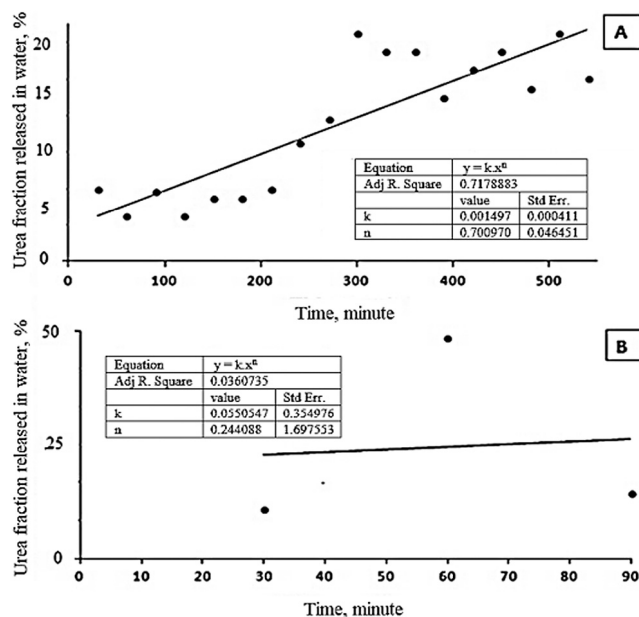

Fig. 3. Release behaviour and kinetic model of (A) SRUF-4 using corn starch and (B) SRUF-7 using HPMC.

3.2. Urea release kinetics and mechanisms

The Peppas equation was used for analyses of release rate model by fitting data of urea release behaviour from static release experiments to the Peppas equation. (Xiaoyu et al., 2013; Fu and Kao, 2010). Then, kinetic constant (k) and diffusion coefficient (n) were calculated using polymath software. The release rate model obtained can be used for prediction of urea release mechanism and the amount of urea in SRUF release so that the utilization of urea will be more efficient. For SRUF-4, regression constant (k) and diffusion coefficient (n) obtained were 0.001497 and 0.70097, respectively. Thus, desorption rate model of SRUF-4 was $Y = 0.001497t^{0.70097}$, as can be seen in Fig. 3A. The desorption rate model could be used to explain urea release mechanism because determination coefficient (R^2) was 0.7178883. Since $0.45 < n < 1.0$, urea in SRUF-4 was released through anomalous transport also known as non-Fickian release as reported in the literature (Li et al., 2016; Fu and Kao, 2010). This result indicated that urea release for SRUF-4 was controlled by diffusion and erosion mechanism associated with the porosity of SRUF-4 structure.

Furthermore, regression constant (k) and diffusion coefficient (n) obtained from urea release behaviour data of SRUF-7 using HPMC as binder were 0.0550847 and 0.244088, respectively. Then, urea release kinetic model of SRUF-7 was $Y = 0.0550847 t^{0.244088}$. This equation can be used to analyse only for the first 50% of urea in SRUF-7 release. This result indicated that diffusion coefficient (n) was less than 0.45. Thus, urea release mechanism of SRUF-7 followed Fickian diffusion. Driven of Fickian diffusion was associated with concentration gradient, diffusion distance, and degree of swelling as reported in the literatures (Siepmann and Siepmann, 2008; Lin et al., 1985; Bhattacharjee and Elimelech, 1997).

3.3. Morphology and characteristics of slow-release urea fertilizers (SRUFs)

Fig. 4 shows SEM images that revealed morphological aspects of natural bentonite, conventional urea fertilizer, SRUF using corn starch as binder (SRUF-4) and SRUF-7 using HPMC as binder. As can be seen from the figure, natural bentonite was observed to contain various sizes of layered structures which were porous (Fig. 4A). Meanwhile, SEM of conventional urea fertilizer clearly shows even surface without porosity (Fig. 4B).

The morphology of natural bentonite changed after urea incorporation process and the use of two different binders. This is because in the SRUF preparation, bentonite that was homogeneously dispersed formed a lattice structure in three-dimensional space. Bentonite molecules may connected with each other by electrostatic bond (Cai et al., 2009; Uslu and Aytimur, 2012). Then, organic polymers of the binders (corn starch or HPMC) dissolved in melted urea and cross-linked the bentonite molecules to consequently strengthen the lattice frame (Xiaoyu et al., 2013). SEM image in Fig. 5C shows that surface of SRUF-4 using corn starch was smoother, more compact and more uniform when compared to surface of SRUF-7 using HPMC (Fig. 4D). SEM image of SRUF-7 using HPMC shows rough surface with irregular coarse particles. This could be due to fewer amounts of HPMC molecules that cross-linked the bentonite molecules. Thus lattice frame in SRUF-7 was weaker than that in SRUF-4.

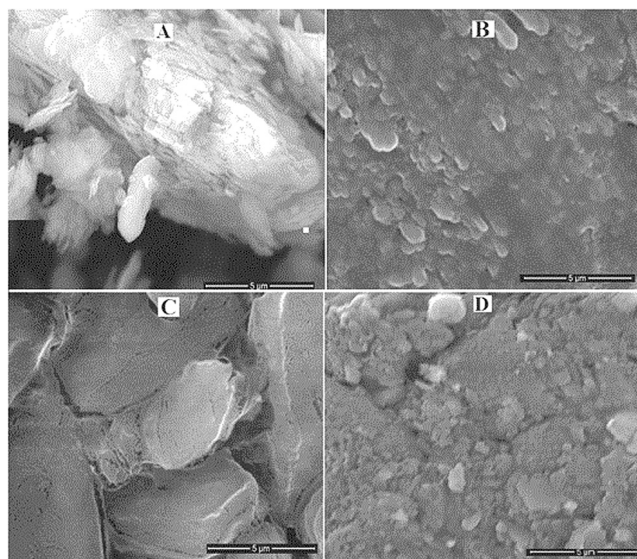

Fig. 4. SEM images of A: natural bentonite, B: conventional urea fertilizer C: SRUF-4, D: SRUF-7.

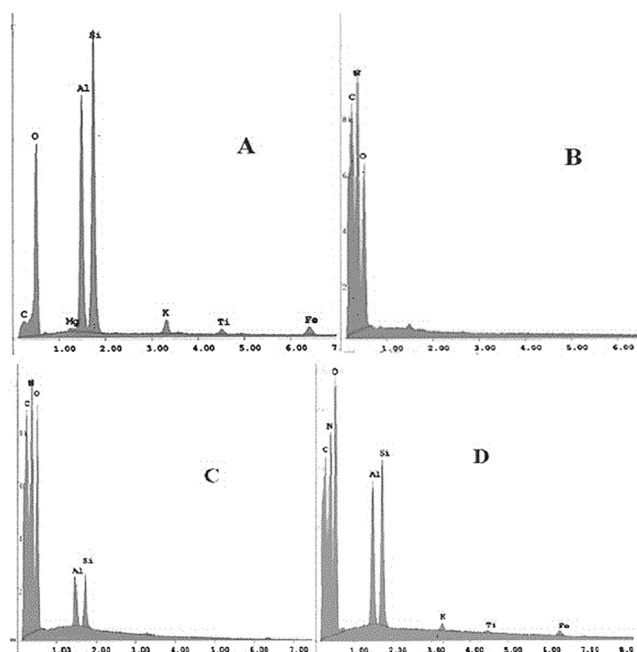

Fig. 5. EDX spectra of A: natural bentonite, B: conventional urea fertilizer, C: SRUF-4, D: SRUF-7.

Fig. 5 shows spectrum of natural bentonite, conventional urea fertilizer, SRUF-4 and SRUF-7 obtained from an energy-dispersive X-ray spectrometer (EDX) which was attached to a SEM. The EDX analysis was carried out to confirm elemental composition of the samples. It can be seen from Fig. 5A that elements detected in natural bentonite were predominantly O, Si and Al, which are bentonite constituents. Elements mostly detected in conventional urea fertilizer were N, C and O, which are urea constituents (Fig. 5B). Corn starch and HPMC are organic polymer that contained predominantly elements of C and O (Shit and Shah, 2014). Furthermore, SRUF-4 and SRUF-7 contained O, Si, Al (bentonite constituents) and N, C and O (urea constituents). These results indicated that urea was successfully incorporated in natural bentonite in the presence of corn starch and HPMC. Elemental compositions of bentonite, urea, SRUF-4 and SRUF-7 can be seen in Fig. 6.

Interactions of urea–bentonite and binder (corn starch and HPMC) were investigated using FTIR analyses. FTIR spectra for conventional urea fertilizer, natural bentonite, slow release urea fertilizer using corn starch as a binder (SRUF-4) and

EDAX ZAF Quantification for Bentonite			EDAX ZAF Quantification for urea		
Element	Wt %	At %	Element	Wt %	At %
C	12.95	19.28	C	17.32	20.43
O	54.12	60.84	N	50.51	51.10
Mg	0.22	0.16	O	32.09	28.42
Al	11.49	7.62	Al	0.08	0.04
Si	17.28	11.00	Total	100.00	100.00
K	1.23	0.56			
Ti	0.65	0.24			
Fe	2.06	0.66			
Total	100.00	100.00			

EDAX ZAF Quantification for SRUF-4			EDAX ZAF Quantification for SRUF-7		
Element	Wt %	At %	Element	Wt %	At %
C	17.15	20.47	C	16.59	20.25
N	45.22	46.29	N	39.09	40.93
O	36.34	32.57	O	39.87	36.55
Al	0.63	0.34	Al	1.82	0.99
Si	0.67	0.34	Si	2.17	1.14
Total	100.00	100.00	K	0.16	0.06
			Ti	0.07	0.02
			Fe	0.22	0.06
			Total	100.00	100.00

Fig. 6. Elemental compositions of Bentonite, Urea, SRUF-4 and SRUF-7.

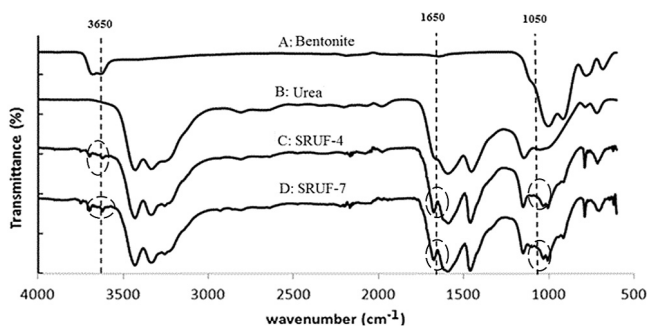

Fig. 7. FTIR spectra of A: natural bentonite, B: urea, C SRUF-4, D: SRUF-7.

slow release urea fertilizer using HPMC as a binder (SRUF-7) are shown in Fig. 7. In the FTIR spectrum for conventional urea fertilizer, it was detected peaks at around 3650 cm^{-1} and 1650 cm^{-1} that confirmed the presence of NH_2 groups and $\text{C}=\text{O}$ bonds. These peaks were not detected in FTIR spectrum for bentonite. In the spectrum of bentonite, peaks observed from 3250 cm^{-1} to 3550 cm^{-1} were attributed to vibrations of O-H (Wen et al., 2017). Then, peak at around 1050 cm^{-1} in the spectrum of bentonite indicated Si-O vibration (Wen et al., 2017; He et al., 2007). After urea incorporation in bentonite with the use of binders, new peaks appeared at around 1650 cm^{-1} and 3700 cm^{-1} in FTIR spectra for SRUF-4 and SRUF-7. Peaks at around 1650 cm^{-1} indicated the presence of $\text{C}=\text{O}$ that is part of $\text{O}=\text{C}-\text{NH}_2$ functional group (Xie et al., 2011; Roshanravan et al., 2015). Then, peaks at around 3700 cm^{-1} could be attributed to the formation of hydrogen bond between $-\text{NH}_2$ groups and the oxygen of the tetrahedral sheets as reported in the literature (Roshanravan et al., 2015; Wen et al., 2016a). It can be assumed that urea incorporation in bentonite with the use of binders resulted in some physical attractions such as the Van der Waals force, hydrogen bond and electrostatic attraction between molecules in slow release fertilizers (SRUFs). This result was agree with that reported in the literature (Xiaoyu et al., 2013).

4. Conclusion

Various slow release urea fertilizers (SRUFs) have been successfully synthesized through incorporation of urea into local bentonite with various binders (corn starch and HPMC) at different proportions. Static release experiments were conducted to investigate kinetic model and urea release mechanism of the SRUFs. It was found that SRUFs using HPMC as a binder had a faster urea releases than those using corn starch as binder due to the more hydrophilicity of HPMC. SRUF-4 using the highest proportion of corn starch (0.8 g) achieved the slowest urea release. As comparison, around 25% urea in SRUF-4 was released after 500 min meanwhile 50% urea was released after 60 min for SRUF-7 using HPMC as binder. Conventional urea fertilizer completely dissolved in water after less than 50 min. Desorption rate model of SRUF-4 was found to be $Y = 0.001497t^{0.70097}$

indicating that urea release for SRUF-4 was controlled by diffusion and erosion mechanism. Meanwhile, urea release kinetic model of SRUF-7 was $Y = 0,0550847 t^{0,244088}$ indicating that urea release for SRUF-7 was associated with concentration gradient, diffusion distance, and degree of swelling. The SRUFs were characterized by SEM-EDX and FT-IR. It was found that surface of SRUF-4 using corn starch was smoother, more compact and more uniform when compared to surface of SRUF-7 using HPMC. Urea incorporation in bentonite with the use of binders resulted in Van der Waals force, hydrogen bond and electrostatic attractions between molecules in SRUFs.

Acknowledgments

Authors gratefully acknowledge the financial support from Ministry of Research, Technology and Higher Education of Indonesia under Grant Scheme of Penelitian Produk Terapan (No. 25/UN26/5/LPPM/2017). Great thanks also go to Ajeng, Lamando and Fitri for the help in data collection for the research activity.

References

- Ali, S., Danafar, F., 2015. Controlled-release fertilizers: Advances and challenges. *Life Sci J.* 12 (11). www.lifesciencesite.com/ljsj/life121115/005_17565life121115_33_45.pdf. (Accessed 15 June 2016).
- Ali, T., Shoaib, M.H., Yousuf, R.I., Jabeen, S., Muhammad, I.N., Tariq, A., 2014. Use of hydrophilic and hydrophobic polymers for the development of controlled release tizanidine matrix tablets. *Braz. J. Pharm. Sci.* 50 (4), 700–818. <http://dx.doi.org/10.1590/S1984-82502014000400016>.
- Bhattacharjee, S., Elimelech, M., 1997. Surface element integration: A novel technique for evaluation of DLVO interaction between a particle and a flat plate. *J. Colloid Interface Sci.* 193, 273–285. <http://dx.doi.org/10.1006/jcis.1997.5076>.
- Cai, D.Q., Wu, Z.Y., Jiang, J., Ding, K.J., Tong, L.P., Chu, P.K., 2009. A unique technology to transform inorganic nanorods into nano-networks. *Nanotechnology* 20, 255–302. <http://dx.doi.org/10.1088/0957-4484/20/25/255302>.
- Chien, S.H., Teixeira, L.A., Cantarella, H., Rehm, G.W., Grant, C.A., Gearhart, M.M., 2016. Agronomic effectiveness of granular nitrogen/phosphorus fertilizers containing elemental sulfur with and without ammonium sulfate: A Review. *Agron. J.* 108, 1203–1213. <https://dl.sciencesocieties.org/publications/aj/pdfs/108/3/1203>.
- Dashi, S., Murthy, P.N., Nath, L., Chowdury, P., 2010. Kinetic modelling on drug release from controlled drug delivery system. *Acta Pol Pharm.* 67 (3), 217–223. http://ptfarm.pl/pub/File/Acta_Poloniae/2010/3/217.pdf.
- Dobermann, A., Ping, J.L., Damchuk, V.I., Simbahan, G.C., Ferguson, R.B., 2003. Classification of crop yield variability in irrigated production fields. *Agron J* 95, 1105–1120. <https://pdfs.semanticscholar.org/3427/8f0451e3906c75d9549fccbe2c1479ddb004.pdf>.
- Fu, Y., Kao, W.J., 2010. Drug release kinetics and transport mechanisms of non-degradable and degradable polymeric delivery systems. *Expert Op. Drug Del.* 7 (4), 429–444. <http://dx.doi.org/10.1517/17425241003602259>.
- He, X.S., Liao, Z.W., Huang, P.Z., Duan, J.X., Ge, R.S., Li, H.B., 2007. Characteristics and performance of novel water absorbent slow release nitrogen fertilizers. *Agri. Sci. China* 6, 338–346.
- Higuchi, T., 1963. Mechanism of sustained-action medication theoretical analysis of rate of release of solid drugs dispersed in solid matrices. *J Pharm Sci* 52, 1145–1149. <http://dx.doi.org/10.1002/jps.2600521210>.
- Hirel, B., Tétu, T., Lea, P.J., Dubois, F., 2011. Improving nitrogen use efficiency in crops for sustainable agriculture. *Sustainability* 3, 1452–1485. <http://dx.doi.org/10.3390/su3091452>.
- Holman, L., Leuenberger, H., 1988. The relationship between solid fraction and mechanical properties of compacts—the percolation theory model approach. *Int J Pharm* 46, 35–44. [http://dx.doi.org/10.1016/0378-5173\(88\)90007-5](http://dx.doi.org/10.1016/0378-5173(88)90007-5).
- Kamalakar, D., Rao, N.L., Jayanthi, J.L., Rao, M.V., 2011. Zinc sulfate controlled release fertilizer with fly ash as inert matrix. *Ind. Streams Res. J. I (V)*, 1–10. <http://oldisrj.lbp.world/UploadedData/322.pdf>.
- Katan, M.B., 2009. Nitrate in foods: Harmful or healthy? *Am J Clin Nutr* 90, 11–22. <http://dx.doi.org/10.3945/ajcn.2009.28014>.
- Korsmeyer, R.W., Peppas, N.A., 1984. Solute and penetrant diffusion in swellable polymers. III. Drug release from glassy poly(HEMA-co-NVP) copolymers. *J Control Rel.* 1, 89–98. <https://www.sciencedirect.com/science/article/pii/0168365984900014>.
- Landschoot, P., 2015. Enhanced efficiency nitrogen fertilizers for turfgrasses. <https://extension.psu.edu/enhanced-efficiency-nitrogen-fertilizers-for-turfgrasses/>. (Accessed 1 October 2017).
- Li, X., Ouyang, J., Yang, H., Chang, S., 2016. Chitosan modified halloysite nanotubes as emerging porous microspheres for drug carrier. *Appl. Clay Sci.* 126, 306–312. <http://dx.doi.org/10.1016/j.clay.2016.03.035>.
- Lin, S.B., Hwang, K.S., Tsay, S.Y., Cooper, S.L., 1985. Segmental orientation studies of polyether polyurethane block copolymers with different hard segment lengths and distributions. *Colloid Polym. Sci.* 263, 128–140. <https://link.springer.com/article/10.1007/BF01412787>.
- Lixiang, Y., Xiaoyu, N., Lin, W., Zhengyan, W., Yuejin, W., Hong, Z., Dongqing, C., Guannan, Q., 2011. A built-in net-type slow-release urea and its production method and its application. <https://patents.google.com/patent/CN102173962/en>. (Accessed 17 May 2016).
- Rahardjo, A.K., Susanto, M.J.J., Kurmiawan, A., Indraswati, N., Ismadji, S., 2011. Modified ponorogo bentonite for the removal of ampicillin from wastewater. *J Hazard Mater.* 190, 1001–1008. <http://dx.doi.org/10.1016/j.jhazmat.2011.04.052>.
- Ravishankara, A.R., Daniel, J.S., Portmann, R.W., 2009. Nitrous oxide (N₂O): The dominant ozone-depleting substance emitted in the 21st century. *Science* 326 (5949), 123–125. <http://science.sciencemag.org/content/326/5949/123.full>.
- Roshanravan, B., Soltani, S.M., Rashid, S.A., Mahdavi, F., Yusop, M.K., 2015. Enhancement of nitrogen release properties of urea-kaolinite fertilizer with chitosan binder. *Chem. Spec. Bioavail.* 27 (1), 44–51. <http://dx.doi.org/10.1080/09542299.2015.1023090>.
- Salman, O.A., 1989. Polyethylene-coated urea: 1. Improved storage and handling properties. *Ind. Eng. Chem. Res.* 28, 630–632. <https://pubs.acs.org/doi/abs/10.1021/ie00089a021>.
- Schjorring, J.K., 1986. Nitrate and ammonium absorption by plants growing at a sufficient or insufficient level of phosphorus in nutrient solutions. *Plant Soil* 91, 313–318. <https://link.springer.com/article/10.1007/BF02198114>.
- Shaviv, A., Raban, S., Zaidel, E., 2003. Modeling controlled nutrient release from polymer coated fertilizers: Diffusion release from single granules. *Environ. Sci. Technol.* 37 (10), 2251–2256. <https://pubs.acs.org/doi/10.1021/es011462v>.
- Shit, S.C., Shah, P.M., 2014. Edible polymers: Challenges and opportunities. *J. Polym.* 1–13. <http://dx.doi.org/10.1155/2014/427259>.
- Siepmann, J., Siepmann, F., 2008. Mathematical modeling of drug delivery. *Int J Pharm* 364, 328–343. <http://dx.doi.org/10.1016/j.ijpharm.2008.09.004>.
- Signor, D., Cerri, C.E.P., 2013. Nitrous oxide emissions in agricultural soils: A review. *Pesqui. Agropecu. Trop.* 43 (3), 322–338. <http://dx.doi.org/10.1590/S1983-40632013000300014>.
- Singh, J., Gupta, S., Kaur, H., 2011. Prediction of in vitro drug release mechanisms from extended release matrix tablet using SSR/SR2 techniques. *Trends App. Sci. Res.* 6 (4), 400–409. <https://scialert.net/fulltext/?doi=tasr.2011.400.409>.

- Thanh, H., Trinh, K.Z.K.S., Basit, A., Azeem, B., 2014. Effect of particle size and coating thickness on the release of urea using multi-diffusion model. *Int. J. Che. Eng. Appl.* 5 (1), 58–63, <http://www.ijcea.org/papers/351-L0008.pdf>.
- Timmins, P., S.R., Pygall., Melia, C.D., 2014. *Hydrophilic Matrix Tablets for Oral Controlled Release*. Springer-Verlag, New York.
- Uslu, I., Aytimur, A., 2012. Production and characterization of poly(vinyl alcohol)/ poly(vinylpyrrolidone) iodine/poly(ethylene glycol) electrospun fibers with (hydroxypropyl)methyl cellulose and aloe vera as promising material for wound dressing. *J. Appl. Pol. Sci.* 124, 3520–3524. <http://dx.doi.org/10.1002/app.35525>.
- Wen, P., Wu, Z., Han, Y., Cravotto, G., Wang, J., Ye, B.C., 2017. Microwave-Assisted synthesis of a novel biochar-based slow-release nitrogen fertilizer with enhanced water-retention capacity. *ACS Sustain. Chem. Eng.* 5 (8), 7374–7382, <https://pubs.acs.org/doi/abs/10.1021/acssuschemeng.7b01721>.
- Wen, P., Wu, Z., He, Y., Ye, B.C., Han, Y., Wang, J., Guan, X., 2016a. Microwave-Assisted synthesis of a semi-interpenetrating polymer network slow-release nitrogen fertilizer with water absorbency from cotton stalks. *ACS Sustain. Chem. Eng.* 4 (12), 6572–6579, <https://pubs.acs.org/doi/abs/10.1021/acssuschemeng.6b01466>.
- Xiaoyu, N., Yuejin, W., Zhengyan, W., Lin, W., Guannan, Q., Lixiang, Y., 2013. A novel slow-release urea fertilizer: Physical and chemical analysis of its structure and study of its release mechanism. *Biosyst. Eng.* 115, 274–282. <http://dx.doi.org/10.1016/j.biosystemseng.2013.04.001>.
- Xie, L.H., Liu, M.Z., Ni, B.L., Zhang, X., Wang, Y.F., 2011. Slow-release nitrogen and boron fertilizer from a functional superabsorbent formulation based on wheat straw and attapulgite. *Chem. Eng. J.* 167, 342–348. <http://dx.doi.org/10.1016/j.cej.2010.12.082>.
- Zengming, Y., Yuejin, W., Jiang, J., Dongqing, C., 2008. Nitrogen fertilizer solidifying method by active soil, flocculants, adsorbent composite material and fertilizer. <https://patents.google.com/patent/CN1850743A/en>. (Accessed 17 May 2016).