



1st ICON - ELTL
International Conference on
English Language Teaching and Learning

ISBN: 978-602-0860-30-5



1st INTERNATIONAL CONFERENCE

ON ENGLISH LANGUAGE TEACHING AND LEARNING

30th NOVEMBER - 1st DECEMBER 2018

PROCEEDINGS

PROCEEDINGS

*"EFL Teaching and Learning in Digital Era
and New Orientation of Language Assessment"*



1st ICON - ELTL
International Conference on
English Language Teaching and Learning

PROCEEDINGS

1st INTERNATIONAL
CONFERENCE
ON ENGLISH LANGUAGE TEACHING AND LEARNING

ISBN: 978-602-0860-30-5

ISBN 978-602-0860-30-5



9 786020 860305

INSTITUTE FOR RESEARCH AND COMMUNITY SERVICE
UNIVERSITY OF LAMPUNG

INSTITUTE FOR RESEARCH AND COMMUNITY SERVICE
UNIVERSITY OF LAMPUNG



1st ICON - ELLT
International Conference on
English Language Teaching and Learning

ISBN: 978-602-0860-30-5

1st INTERNATIONAL CONFERENCE

ON ENGLISH LANGUAGE TEACHING AND LEARNING

30th NOVEMBER - 1st DECEMBER 2018



PROCEEDINGS

*"EFL Teaching and Learning in Digital Era
and New Orientation of Language Assessment"*

ORGANIZED BY:

INSTITUTE FOR
RESEARCH AND COMMUNITY SERVICE
UNIVERSITY OF LAMPUNG

ENGLISH EDUCATION STUDY PROGRAM
FACULTY OF TEACHER TRAINING AND EDUCATION
UNIVERSITY OF LAMPUNG

Editorial Team

Editor in Chief

1. Dr. Ari Nurweni, M.A. University of Lampung

Editors

1. Gede Eka Putrawan, S.S., M.Hum. University of Lampung
2. Rafista Deviyanti, S.Pd., M.Pd. University of Lampung

Section Editors

1. Novita Nurdiana, S.Pd., M.Pd. University of Lampung
2. Khairun Nisa, S.Pd., M.Pd. University of Lampung

Reviewers

1. Prof. Dr. Patuan Raja, M.Pd. University of Lampung
2. Prof. Dr. Ag. Bambang Setiyadi, M.A. University of Lampung
3. Prof. Dr. Cucu Sutarsyah, M.A. University of Lampung
4. Mahpul, PhD. University of Lampung

Preface

The English Education Study Program, Department of Language and Arts Education, Faculty of Teacher Training and Education, University of Lampung was honored to host the 1st International Conference on English Language Teaching and Learning (1st ICON-ELTL) in the heart of the city of Bandar Lampung from 30 November – 1 December 2018. The conference chair, Dr Ari Nurweni, delivered her welcome address, followed by the conference official opening by the Dean of the Faculty of Teacher Training and Education on Friday morning 30 November 2018.

The conference theme “EFL Teaching and Learning in Digital Era and New Orientation of Language Assessment” was an invitation to discuss English language teaching and learning-related issues (including blended learning, communicative competence in EFL context, ICT in EFL teaching and learning, TBLT, English curriculum and material development, teaching methodology, communication strategies of EFL learners, learning style, learning strategy, translation in EFL teaching and learning, literature in EFL teaching and learning, culture in EFL teaching and learning, and other relevant topics) in today’s advancement of digital era. The aim of the conference was to bring together academics, researchers, teachers, and students to exchange ideas, experiences, and research findings in the field of English language and assessment to make better, more efficient and impactful teaching and learning.

The conference was attended by 162 participants and 31 presenters from all over Indonesia. Two invited keynote papers were delivered on the first day of the conference, the first was presented by Eric L. Campbell (Director of CONNECT, USA) in the morning and the second was presented by Dr Vahid Aryadoust (National Institute of Education, Singapore) in the afternoon. On the second day, other two invited keynote papers were also presented by Prof. John Read (University of Auckland, New Zealand) and Prof. Patuan Raja (University of Lampung, Indonesia). In addition, 31 papers were also presented by registered presenters in the parallel sessions of the conference.

The conference program represents the efforts of many individuals. Therefore, we would like to express our gratitude to the members of the organizing committee for putting much effort into ensuring the success of day-to-day operation of the conference and the reviewers for their hard work in reviewing submissions. We also thank the four invited keynote speakers for sharing their

insights with us. Finally, the conference would not be possible without the excellent papers contributed by authors. We thank all authors for their contributions and participation in the 1st ICON-ELTL 2018.

We hope that this conference will further stimulate research on English language teaching and learning in today's advancement of digital era and provide academics, researchers, teachers, and students with better understanding, knowledge, and ideas for further research. We feel honored to serve the best recent scientific knowledge and development in the field of English language teaching and learning. In addition, we also hope that these proceedings will furnish scholars from all over the world with an excellent reference book.

Realizing that there were still some weaknesses during the conference, we do have an apology to make to everyone and we hope we will be able to hold better international conferences in the future. Finally, it was with great pleasure that we had the opportunity to host such a conference. Thank you.

Ari Nurweni
Conference Chair

Gede Eka Putrawan
Conference Co-Chair

CONFERENCE SCHEDULE AT-A-GLANCE

THE 1ST INTERNATIONAL CONFERENCE ON ENGLISH LANGUAGE TEACHING AND LEARNING
UNIVERSITY OF LAMPUNG

Fri – Sat, 30 November – 1 December 2018, Bandar Lampung, Indonesia

Time	Activity	Speaker/PIC	Location
Friday, 30 November 2018			
08.00 – 08.50	Conference Registration	Dr. Feni Munifatullah, M.Hum.	Lobby, Hall K, 2 nd Floor
09.00 – 09.05	Opening	MC	Hall K, 2 nd Floor
09.05 – 09.15	National anthem of Indonesia	Amiswari and PSPBI Choir	
09.15 – 09.25	Welcome dance	PSPBI Dancers	
09.25 – 09.35	Chair's report	Dr. Ari Nurweni, M.A.	
09.35 – 09.50	Welcome remarks from Rector of the University of Lampung and opening	Prof. Dr. Ir. Hasriadi Mat Akin, M.P.	
09.50 – 10.00	Prayers	Hendi Nur Pratama	
10.00 – 10.30	<i>Coffee and refreshment break</i>	Khairun Nisa, S.Pd., M.Pd.	
10.30 – 11.30	Keynote Speaker 1: Eric L. Campbell <i>The LESYNZO Three-Dimensional Model for Spoken Language Assessment</i>	PIC: Dr. Flora, M.Pd.	
11.30 – 13.00	<i>Networking luncheon</i>	Khairun Nisa, S.Pd., M.Pd.	Hall K, 2 nd Floor
13.00 – 15.00	Parallel Sessions	Moderators	K1-5, 1 st Floor
15.00 – 15.30	<i>Coffee and refreshment break</i>	Khairun Nisa, S.Pd., M.Pd.	Hall K, 2 nd Floor
15.30 – 16.30	Keynote Speaker 2: Dr Vahid Aryadoust <i>Language Assessment Research by Employing Neuro-imaging and Eye-tracking Method</i>	PIC: Prof. Bambang Setiyadi, M.A.	Hall K, 2 nd Floor
Saturday, 1 December 2018			
08.15 – 09.15	Keynote Speaker 3: Prof. John Read <i>Vocabulary Assessment in the Digital Era</i>	PIC: Hery Yufrizal, PhD	Hall K, 2 nd Floor
09.15 – 09.45	<i>Coffee and refreshment break</i>	Khairun Nisa, S.Pd., M.Pd.	Hall K, 2 nd Floor
09.45 – 10.45	Parallel Sessions	Moderators	K1-5, 1 st Floor
10.45 – 11.45	Keynote Speaker 4: Prof. Dr. Patuan Raja <i>Writing Assessment</i>	PIC: Mahpul, PhD	Hall K, 2 nd Floor
11.45 – 12.00	Wrapping Up and Closing	Dean of Teacher Training and Education Faculty, Prof. Dr. Patuan Raja, M.Pd.	Hall K, 2 nd Floor
12.00 – 13.00	<i>Networking luncheon</i>	Khairun Nisa, S.Pd., M.Pd.	Hall K, 2 nd Floor

CONFERENCE SCHEDULE
THE 1ST INTERNATIONAL CONFERENCE ON
ENGLISH LANGUAGE TEACHING AND LEARNING (1ST ICON-ELTL 2018)
UNIVERSITY OF LAMPUNG
Fri – Sat, 30 November – 1 December 2018, Bandar Lampung, Indonesia

No.	Time	Activity	Speaker/PIC	Location	
Friday, 30 November 2018					
1	08.00 – 08.50	Conference Registration	Dr. Feni Munifatullah, M.Hum.	Lobby	
2	09.00 – 09.05	Opening	MC	Hall K, 2 nd Floor	
3	09.05 – 09.15	National anthem of Indonesia	Amiswari and PSPBI Choir		
4	09.15 – 09.25	Welcome dance	PSPBI Dancers		
5	09.25 – 09.35	Chair's report	Dr. Ari Nurweni, M.A.		
6	09.35 – 09.50	Welcome remarks from Rector of the University of Lampung and opening	Prof. Dr. Ir. Hasriadi Mat Akin, M.P.		
7	09.50 – 10.00	Prayers	Hendi Nur Pratama		
8	10.00 – 10.30	<i>Coffee and refreshment break</i>	Khairun Nisa, S.Pd., M.Pd.		
9	10.30 – 11.30	Keynote Speaker 1: Eric L. Campbell <i>The LESYNOS Three-Dimensional Model for Spoken Language Assessment</i>	PIC: Dr. Flora, M.Pd.		
10	11.30 – 13.00	<i>Networking luncheon</i>	Khairun Nisa, S.Pd., M.Pd.		
Parallel Sessions					
No.	Time	Title	Presenter	Location	
Panel 1 ICT in EFL Teaching and Learning					
<i>Moderator: Annelly Prima Santoso</i>					
1	13.00 – 13.40	Canvas: A Digital Tool in ELT	Ratu Sarah Pujasari <i>Siliwangi University</i>	Room K1, 1 st Floor	
2		The Influence of Blog Wordpress Towards Students' Writing Ability on Recount Text	Fitri Nur Asy-Syifa, Yudi Juniardi <i>University of Sultan Ageng Tirtayasa</i>		
Panel 2 English Language Teaching and Learning, Curriculum, and Material Development					
<i>Moderator: Annelly Prima Santoso</i>					
3	13.40 – 15.00	TINKERBEL: The Bloom-Anderson-Krathwohl's Cognitive Levels and K 13 Text Based English Teaching in Vocational Schools	Nina Fatriana <i>SMKN 2 Kalianda</i>		
4		Students' Difficulties in Describing Something	Dewi Sri Kuning <i>STKIP Muh. Kotabumi</i>		
5		Error Analysis in Subject-Verb Agreement of English Department Graduate Student's Thesis as EFL Learners based on Surface Strategy Taxonomy	Khairun Nisa <i>University of Lampung</i>		

No.	Time	Activity	Speaker/PIC	Location
6		Altruism in English Language Teaching and Learning Documents in Indonesia	Ratna Dewanti <i>UNJ</i>	
Panel 3 English Language Teaching and Learning, Curriculum, and Material Development <i>Moderator: Hendi Nur Pratama</i>				
1	13.00 – 14.00	The influence of using realia to improve students' Vocabulary	Alanda Liantara <i>UM Metro</i>	Room K2, 1 st Floor
2		An English Teaching Model for Non-English Students in One of State Universities: Indonesian Context	Ujang Suparman <i>University of Lampung</i>	
3		An analysis of negotiation of meaning at the first year students of SMAN 4 Bandar Lampung	Novita Nurdiana <i>University of Lampung</i>	
4	14.00 – 15.00	Error made by Fourth semester students of English study program in Pronouncing English Voiced and Unvoiced Fricative Dental	Hengki <i>Universitas Negeri Papua</i>	
5		Implementing Content Language Integrated Learning (CLIL) at a Higher Education Institution in Indonesia	Huzairin <i>University of Lampung</i>	
6		Students' Difficulties of Writing an Essay	Rulik Setiani <i>STKIP Kotabumi</i>	
Panel 4 English Language Teaching and Learning, Curriculum, and Material Development <i>Moderator: Eka Riski</i>				
1	13.00 – 14.20	The Concept of Meaning	Cucu Sutarsyah <i>University of Lampung</i>	Room K3, 1 st Floor
2		Hypno-teaching in English Language Classroom: Theoretical Issues and Practical Guides	Ruslan <i>Siliwangi University</i>	
3		Enhancing Speaking Fluency through 4/3/2 Technique of EFL Students in Indonesia	Hery Yufrizal <i>University of Lampung</i>	
4		Teachers' perception toward English teaching in full day school in Yogyakarta in the academic year of 2017/2018	Bambang Widi Pratolo <i>University of Ahmad Dahlan</i>	
Panel 5 Language Assessment <i>Moderator: Eka Riski</i>				
5	14.20 – 15.00	Employing Self-Assessment Technique to Promote Student's Writing Ability in Composing Cause-Effect Essay at Universitas Muhammadiyah Gorontalo	Indah Wardaty Saud <i>Muh. University of Gorontalo</i>	

No.	Time	Activity	Speaker/PIC	Location	
6		Challenges in Assessing Young Language Learners in The Indonesian Context	Nury Supriyanti <i>Yogyakarta State University</i>		
Panel 6 Learning Styles, Strategies, and Interaction <i>Moderator: Desi Setia N.</i>					
1	13.00 – 14.00	Gender Differences in Written Discourse Competence	Dian Agustina Purwanto Wakerkwa <i>Universitas Sebelas Maret</i>	Room K4, 1 st Floor	
2		How successful language learners use strategies in learning speaking	Umi Rokhyati <i>University of Ahmad Dahlan</i>		
3		(Re)Constructing Students' Identity in EFL Classroom Interactions	Meinarni Susilowati <i>UIN Maulana Malik Ibrahim, Malang</i>		
Panel 7 Translation, Literature, and Culture in EFL Teaching and Learning <i>Moderator: Desi Setia N.</i>					
4	14.00 – 15.00	Translation as a learning strategy by EFL learners in a public university in Indonesia	Gede Eka Putrawan <i>University of Lampung</i>		
5		Analyzing Cultural Transfer in ELT Class of Senior High School Teachers	M. Sukirlan <i>University of Lampung</i>		
6		The use of long functional texts with Lampung local wisdom in English language teaching	Agatha Nila Sukma M. <i>SMPN 20 Bandar Lampung</i>		
7		An Analysis of Theme and Rheme in Advertisement in English of Forbes Magazine Indonesia Edition Volume 8 Issue 11 Page 78 on November 2017	Yanuaris Yanu Dharmawan <i>UBL</i>		
8		Gender and Cultural Familiarity in Reading Material	Elis Susanti <i>STKIP Muh. Kotabumi</i>		
9	15.00 – 15.30	<i>Coffee and refreshment break</i>	Khairun Nisa, S.Pd., M.Pd.		Hall K, 2 nd Floor
10	15.30 – 16.30	Keynote Speaker 2: Dr Vahid Aryadoust <i>Language Assessment Research by Employing Neuro-imaging and Eye-tracking Method</i>	PIC: Prof. Bambang Setiyadi, M.A.	Hall K, 2 nd Floor	
Saturday, 1 December 2018					
1	08.15 – 09.15	Keynote Speaker 3: Prof. John Read <i>Vocabulary Assessment in the Digital Era</i>	PIC: Hery Yufrizal, PhD	Hall K, 2 nd Floor	
2	09.15 – 09.45	<i>Coffee and refreshment break</i>	Khairun Nisa, S.Pd., M.Pd.	Hall K, 2 nd Floor	
Parallel Sessions					
Panel 8 Blended Learning					

No.	Time	Activity	Speaker/PIC	Location
<i>Moderator: Resti Rahmawati</i>				
1	09.45 – 10.45	Collaborative Blended Learning Activities to Improve Extrovert and Introvert Students' Argumentative Essay Writing Ability and Their Perception	Ani Novitasari <i>University of Lampung</i>	Room K1, 1 st Floor
2		The Effect of Blended Learning Activity in Improving the Students' English-Speaking Skill in the Context of English as a Foreign Language	Rachma Vivien Belinda <i>University of Lampung</i>	
3		Mobile Learning: The Impact of WhatsApp Usage in English Language Learning	Berlinda Mandasari <i>Universitas Teknokrat Indonesia</i>	
Panel 9 Blended Learning				
<i>Moderator: Dias Fatmasari</i>				
1	09.45 – 10.45	The Effect of Instagram on the Students' Writing Ability at Undergraduate Level	Achmad Yudi Wahyudin <i>Universitas Teknokrat Indonesia</i>	Room K2, 1 st Floor
2		Undergraduate Students' Attitudes to the Implementation of WhatsApp Group As Their Learning Media in the EFL Classroom	Fatimah Mulya Sari <i>Universitas Teknokrat Indonesia</i>	
3		Cartoon Films and Its Correlation of Students Vocabulary Mastery	Dedy Subandowo Meilani Ambariyani <i>UM Metro</i>	
Panel 10 ICT in EFL Teaching and Learning				
<i>Moderator: Desi Setia N.</i>				
1	09.45 – 10.45	Enhancing Students' Reading Skills in the Digital Era through Problem Solving Based-Reading	Ari Nurweni <i>University of Lampung</i>	Room K3, 1 st Floor
2		The Urgency of Digital Learning to Create Global Citizens	Hermi Yanzi <i>University of Lampung</i>	
3		Ethnic Snake Game: A Study on the Use of Multimedia in Speaking Class for Electrical Engineering Students	Lulud Oktaviani <i>Universitas Teknokrat Indonesia</i>	
4	10.45 – 11.45	Keynote Speaker 4: Prof. Dr. Patuan Raja <i>Writing Assessment</i>	PIC: Mahpul, PhD	Hall K, 2 nd Floor
5	11.45 – 12.00	Wrapping Up and Closing	Dean of Teacher Training and Education Faculty, Prof. Dr. Patuan Raja, M.Pd.	Hall K, 2 nd Floor
6	12.00 – 13.00	<i>Networking luncheon</i>	Khairun Nisa, S.Pd., M.Pd.	Hall K, 2 nd Floor
THANK YOU				

TABLE OF CONTENTS

A PRACTITIONER’S MODEL FOR ORAL LANGUAGE ASSESSMENT IN THE EFL CLASSROOM	1
<i>Eric L. Campbell, CONNECT, USA</i>	
VOCABULARY ASSESSMENT IN THE DIGITAL ERA	2 – 13
<i>John Read, The University of Auckland</i>	
USING EYE TRACKING AND NEUROIMAGING IN LISTENING ASSESSMENT: UNDERSTANDING THE ROLE OF TEST METHODS	14 – 19
<i>Vahid Aryadoust, Nanyang Technological University, Singapore</i>	
THE INFLUENCE OF BLOG WORDPRESS TOWARDS STUDENTS’ WRITING ABILITY ON RECOUNT TEXT	20 – 27
<i>Fitri Nur Asy-Syifa, Yudi Juniardi, John Pahamzah, & Delsa Miranty, University of Sultan Ageng Tirtayasa</i>	
TINKERBEL: THE BLOOM-ANDERSON-KRATHWOHL’S COGNITIVE LEVELS AND K 13 TEXT BASED ENGLISH TEACHING IN VOCATIONAL SCHOOLS	28 – 38
<i>Nina Fatriana, SMKN 2 Kalianda South Lampung</i>	
STUDENTS’ DIFFICULTIES IN DESCRIBING SOMETHING	39 – 47
<i>Dewi Sri Kuning, STKIP Muhammadiyah Kotabumi</i>	
ERROR ANALYSIS IN SUBJECT-VERB AGREEMENT OF ENGLISH DEPARTMENT GRADUATE STUDENT’S THESIS AS EFL LEARNERS BASED ON SURFACE STRATEGY TAXONOMY	48 – 55
<i>Khairun Nisa, University of Lampung</i>	
THE INFLUENCE OF USING REALIA TO IMPROVE STUDENTS’ VOCABULARY AT SMP N 2 NATAR IN THE ACADEMIC YEAR OF 2017/2018	56 – 63
<i>Eva Faliyanti & Alanda Liantara, Muhammadiyah University of Metro</i>	
IMPLEMENTING CONTENT LANGUAGE INTEGRATED LEARNING (CLIL) AT A HIGHER EDUCATION INSTITUTION	64 – 71
<i>Huzairin, Basturi Hasan, & Sudirman, University of Lampung</i>	

STUDENTS' DIFFICULTIES OF WRITING AN ESSAY	72 – 79
<i>Rulik Setiani & Dewi Sri Kuning, STKIP Muhammadiyah Kotabumi</i>	
THE CONCEPT OF MEANING	80 – 92
<i>Cucu Sutarsyah, University of Lampung</i>	
ENHANCING SPEAKING FLUENCY THROUGH 4/3/2 TECHNIQUE OF EFL STUDENTS	93 – 100
<i>Hery Yufrizal, University of Lampung</i>	
EMPLOYING SELF-ASSESSMENT TECHNIQUE TO PROMOTE STUDENT'S WRITING ABILITY IN COMPOSING CAUSE-EFFECT ESSAY AT UNIVERSITAS MUHAMMADIYAH GORONTALO	101 – 106
<i>Indah Wardaty Saud, Yulan Puluhulawa, & Dahlia Husain Universitas Muhammadiyah Gorontalo</i>	
TRANSLATION AS A LEARNING STRATEGY BY EFL LEARNERS IN A PUBLIC UNIVERSITY IN INDONESIA	107 – 119
<i>Gede Eka Putrawan, University of Lampung</i>	
ANALYZING CULTURAL TRANSFER IN ELT CLASS OF SENIOR HIGH SCHOOL TEACHERS.....	120 – 136
<i>Muhammad Sukirlan, University of Lampung</i>	
THE USE OF LONG FUNCTIONAL TEXTS WITH LAMPUNG LOCAL WISDOM IN ENGLISH LANGUAGE TEACHING	137 – 143
<i>Agatha Nila Sukma M., SMP Negeri 20 Bandar Lampung</i>	
AN ANALYSIS OF THEME AND RHEME IN AN ADVERTISEMENT.....	144 – 150
<i>Yanuaris Yanu Dharmawan, Universitas Bandar Lampung</i>	
GENDER AND CULTURAL FAMILIARITY IN READING MATERIAL	151 – 160
<i>Elis Susanti, Rini Susilowati & Asep Hardiyanto, STKIP Muhammadiyah Kotabumi</i>	

COLLABORATIVE BLENDED LEARNING ACTIVITIES TO IMPROVE EXTROVERT AND INTROVERT STUDENTS' ARGUMENTATIVE ESSAY WRITING ABILITY AND THEIR PERCEPTION	161 – 176
<i>Ani Novitasari, Patuan Raja, & Flora, University of Lampung</i>	
MOBILE LEARNING: THE IMPACT OF WHATSAPP USAGE IN ENGLISH LANGUAGE LEARNING	177 – 188
<i>Berlinda Mandasari & Shafa Tiara P. Agusty, Universitas Teknokrat Indonesia</i>	
UNDERGRADUATE STUDENTS' ATTITUDES TO THE IMPLEMENTATION OF WHATSAPP GROUP AS THEIR LEARNING MEDIA IN THE EFL CLASSROOM	189 – 196
<i>Fatimah Mulya Sari, Universitas Teknokrat Indonesia</i>	
CARTOON FILMS AN ITS CORRELATION TO STUDENTS VOCABULARY MASTERY	197 – 203
<i>Dedy Subandowo & Meilani Ambariyani, Muhammadiyah University of Metro</i>	
PROMOTING DIGITAL LEARNING TO ENHANCE STUDENT COMPETENCIES AS GLOBAL CITIZENS.....	204 – 214
<i>Hermi Yanzi & Obby Taufik Hidayat, University of Lampung</i>	
ETHNIC SNAKE GAME: A STUDY ON THE USE OF MULTIMEDIA IN SPEAKING CLASS FOR ELECTRICAL ENGINEERING STUDENTS	215 – 225
<i>Lulud Oktaviani, Universitas Teknokrat Indonesia</i>	
THE EFFECT OF INSTAGRAM ON THE STUDENTS' WRITING ABILITY AT UNDERGRADUATE LEVEL	226 – 234
<i>Achmad Yudi Wahyudin & Fatimah Mulya Sari, Universitas Teknokrat Indonesia</i>	
THE EFFECT OF BLENDED LEARNING ACTIVITY IN IMPROVING THE STUDENTS' ENGLISH SPEAKING SKILL IN THE CONTEXT OF ENGLISH AS A FOREIGN LANGUAGE	235 – 240
<i>Rachma Vivien Belinda, Patuan Raja, & Ari Nurweni, University of Lampung</i>	

A PRACTITIONER'S MODEL FOR ORAL LANGUAGE ASSESSMENT IN THE EFL CLASSROOM

Eric L. Campbell

A Practitioner of Spoken Language Assessment, CONNECT, USA

ABSTRACT

In recent years, a great deal of research has been conducted regarding assessment in spoken language. While much of this research provides helpful information, the fact remains that the bulk of it has been performed by linguists and others at such a high-level that the findings are not conducive for use in the majority of assessment situations around the world. As a result, those who most often conduct speaking assessment, namely classroom teachers, are left wondering whether it is even possible to repeatedly, accurately, and objectively evaluate student language abilities in speaking without it becoming too cumbersome for them to conduct. This seminar will present a model developed by a practitioner of spoken language assessment, based on his experience in teaching EFL and ESL students in Indonesia. The model addresses the four major concerns of repeatability, accuracy, objectivity, and simplicity such that any assessor who is familiar with the concepts and instruments proposed can implement it with minor adjustments for speakers of any language at any age or fluency level.

Keywords: *spoken language assessment, speaking, EFL, ESL*

VOCABULARY ASSESSMENT IN THE DIGITAL ERA

John Read

The University of Auckland
School of Cultures, Languages and Linguistics
Private Bag 92019, Auckland 1142, New Zealand
ja.read@auckland.ac.nz

ABSTRACT

The digital era has opened new opportunities for sophisticated ways of assessing the vocabulary knowledge and ability of second language learners. On the one hand, the analysis of large computer corpora generates much more comprehensive information about the frequency, grammatical functioning and uses of vocabulary items than was available before, and thus it provides a reliable basis for selecting words to assess and for writing test items. On the other hand, vocabulary tests are particularly suitable for computer administration, including the use of automated scoring. It is important, though, to recognise the ongoing need for human judgements to complement the contributions of the digital tools. This paper will have three main parts. In the first, the focus is on the use of word frequency information and other data as input to general tests of vocabulary size, as well as tests of more specialised aspects of vocabulary. This will be illustrated by my recent work to develop tests of academic vocabulary knowledge. Secondly, the paper will consider the strengths and weaknesses of the test formats which are typically used for vocabulary assessment and how they may be enhanced in the digital environment. One particular innovation is the measurement of response times to test items, as exemplified by the research of Michael Harrington and his colleagues to investigate the construct of lexical facility. In the third part, there will be some discussion of automated scoring, and more specifically the contribution of lexical measures to automated writing evaluation. This represents a broader concept of vocabulary assessment as being, in Read's (2000) terms, embedded, comprehensive and context-dependent. Although the calculation of lexical statistics offers high reliability, the issue of whether it provides a valid basis for assessment is more debatable. It is one of a number of situations where the automation of vocabulary testing needs to be complemented by appropriate human judgements.

Keywords: *language testing, vocabulary assessment, lexical measures, computer-based tests*

I. INTRODUCTION

Computer technology has transformed modern society in ways that we could scarcely imagine just a few decades ago. We can see the effects in English language teaching generally in terms of the abundance of resources that are available online for teachers and learners, including access to authentic uses of the language and opportunities to communicate in the target language far beyond their local community. However, in some respects this technology has been slower to have an impact on language tests and examinations. There are many web-based English tests that are little more than online

versions of existing paper-based tests. Even in large international tests, backed by the resources of the major test publishers, the amount of innovation in testing practice is less than one might expect. In this paper, I will discuss how these observations apply in the case of assessing vocabulary knowledge and use.

In my book *Assessing vocabulary* (Read, 2000), I presented a framework for describing vocabulary assessment from a broad perspective. On the one hand, it characterises conventional vocabulary tests as being *discrete*, *selective*, and *context-independent*. They are discrete in that they are designed to assess vocabulary knowledge as a separate construct in its own right; they are selective in that they are based on a selection of words that is suitable for the assessment purpose; and they present the target words with little if any context, in the same fashion as words in a dictionary or a word list, as individual semantic units. Well-designed tests of this kind are remarkably reliable and serve as good estimates of overall proficiency in the language. The most commonly used test formats – multiple-choice, true-false (or Yes/No), word—definition matching, and word translation – also lend themselves well to computer delivery and are the item types that are most likely to be available in simple test-authoring software.

On the other hand, such formats need to be complemented by others that are *embedded*, *comprehensive* and *context-dependent*. Assessments are embedded when vocabulary knowledge is measured as part of a larger construct of language ability. This applies particularly to speaking and writing tasks where use of vocabulary is one of several criteria used to rate the test-takers' performance. The assessment is comprehensive in the sense that the raters make an overall judgement about how vocabulary is used in the test-takers' spoken or written output, rather than basing their scoring on individual target words. And the learners also need to use words that are semantically and stylistically appropriate to the context of the task they are given. Apart from rater judgements, some of the lexical qualities of embedded assessments can be assessed by calculating lexical statistics. This provides the basis for automated assessments of speaking and writing by computer, which I will return to later.

II. TESTING VOCABULARY DEPTH

In exploring how advances in digital media have enhanced the process of developing new vocabulary tests, I would like to draw on my own recent experience of designing new tests of depth of vocabulary knowledge. Vocabulary depth complements the more widely applied concept of vocabulary size. Whereas tests of vocabulary size usually involve a simple test format to show whether learners can link form and meaning for a large sample of target words, a test of depth is designed to assess how well a smaller sample of words are known, in terms of different meanings of each word, how the word functions grammatically, what collocations it can enter into, what other words are associated with it semantically, how the word is used stylistically, and so on. Nation's framework of "What is involved in knowing a word" (2013, p. 49) is the most comprehensive and influential statement of these aspects of word knowledge. Since it is not practical to assess all of these aspects for individual words, tests of vocabulary depth have tended to focus on particular dimensions of word knowledge (Read, 2004).

One prominent approach to testing depth has been my own word associates format. In its original form (Read, 1993), it presented a target word together with eight other words, four of which were related in various ways to the target word and four were not:

edit
arithmetic film pole publishing
revise risk surface text

In this case, the four associates are “film”, “publishing”, “revise” and “text”. The test consisted of a sample of 50 target words from the University Word List.

A second format (Read, 1998) was designed specifically to test knowledge of adjectives, and presented paradigmatic (synonymous) and syntagmatic (collocational) associates separately:

conscious

awake healthy knowing laughing face decision effort student

Figure 1. A sample word associates item

The correct answers here are “awake”, “knowing”, “decision” and “effort”.

Numerous other authors and researchers have subsequently explored aspects of this type of test and adapted the format to meet various assessment needs (for reviews, see Read, 2012; Zhang & Koda, 2017). However, there is a persistent idea that – despite its limitations – my 1998 format is some kind of standard measure of depth of vocabulary knowledge.

Recently I have been working on a new format for testing depth, which incorporates the word associates concept but takes it further. Part of the thinking behind this new approach is that we should develop vocabulary tests for particular purposes and for specific populations of learners, rather than the generic, one-size-fits-all idea represented by the Vocabulary Levels Test and the original Vocabulary Size Test. I will discuss two test development projects I have conducted and use them to illustrate how current online tools have facilitated the process of creating new vocabulary tests. When writing the two word associates tests mentioned above in the early 1990s, I had to rely a great deal on my own judgement, along with some reference to learner dictionaries, to select the words that would be the associates and distractors, according to their meanings and their collocational possibilities. Although subjective judgement is still required to write good vocabulary test items, these judgements can be much better informed now by online tools.

II.1 A Business Vocabulary Test

The first project has been to develop a vocabulary test that would be useful for first-year Business students at the University of Auckland, particularly for international students who have English as an additional language. In their first year these students are required to take

a sequence of two courses BUSINESS 101 and BUSINESS 102. The question is how well these students know the non-technical business-oriented words that occur frequently in the set readings for these two courses. As a first step I created a mini-corpus from the readings, consisting of 40 articles and chapters for a total of 344, 793 running words. I analysed the mini-corpus using #LancsBox, a set of corpus analysis tools developed by the Centre for Corpus Approaches to Social Science (CASS) at Lancaster University in the UK (<http://corpora.lancs.ac.uk/lancsbox/>). This toolbox tags words by part of speech; it provides data on word frequency in individual corpora or across corpora; it presents collocates of target words in both tabular form and graphically; and displays words in context in concordance lines.

As the basis for the test I selected 20 target words from the mini-corpus: *global, investment, quality, profitable, consumer, local, competitive, performance, promote, product, target, segments, provide, strategic, traditional, variable, diverse, direct, capital* and *credit*. The next step was to devise a test format that would assess three aspects of the knowledge of these words:

1. Knowledge of synonyms or words with a related meaning to the target word.
2. Knowledge of collocates of the target word; words that go together to form a phrase.
3. Knowledge of other members of the word family: derived and inflected forms.

After some initial drafting, the following type of item emerged:

performance	A	B	C
acceptance		_____ cases	a poorly performing company
achievement		employee _____	they are <u>performantly</u> similar
functioning		results _____	some sectors performed well
separation		_____ standards	the overall <u>performity</u> of the market

Figure 2. A sample item in the trial version of the Business English Vocabulary Test

The columns represent the three knowledge components of the target word *performance*, and the intended answers are highlighted in bold font. As much as possible, the words used in the item, in both the correct answers and the distractors, were frequent in the mini-corpus. The same applied to the meanings expressed by the correct answers in Column A. The format in Column B recognises the fact that collocates may be either to the left or the right of the target word and thus represents an extension of the 1998 version of the word associates format, where noun collocates always occurred to the right of the target adjectives. In the original draft the word forms in Column C were presented in isolation, but in the current item type they occur in a phrase or short sentence, in order to signal more clearly the intended part of speech, and to provide further possible collocations of the target word.

Thus far, the draft test has been reviewed by English language tutors in the Business School and then trialled with a small group of Business students. After some revisions were made, it was decided to make the test available as a quiz on the university's learning management system, Canvas, as part of a range of online resources for Business students to develop their language and academic literacy skills. The switch to a computer-based test meant that the three parts of the test item for each target word could not be presented in a single row, as in the sample item above. Instead each part appears as a separate item, as shown in the screenshot below for the target word *global*:

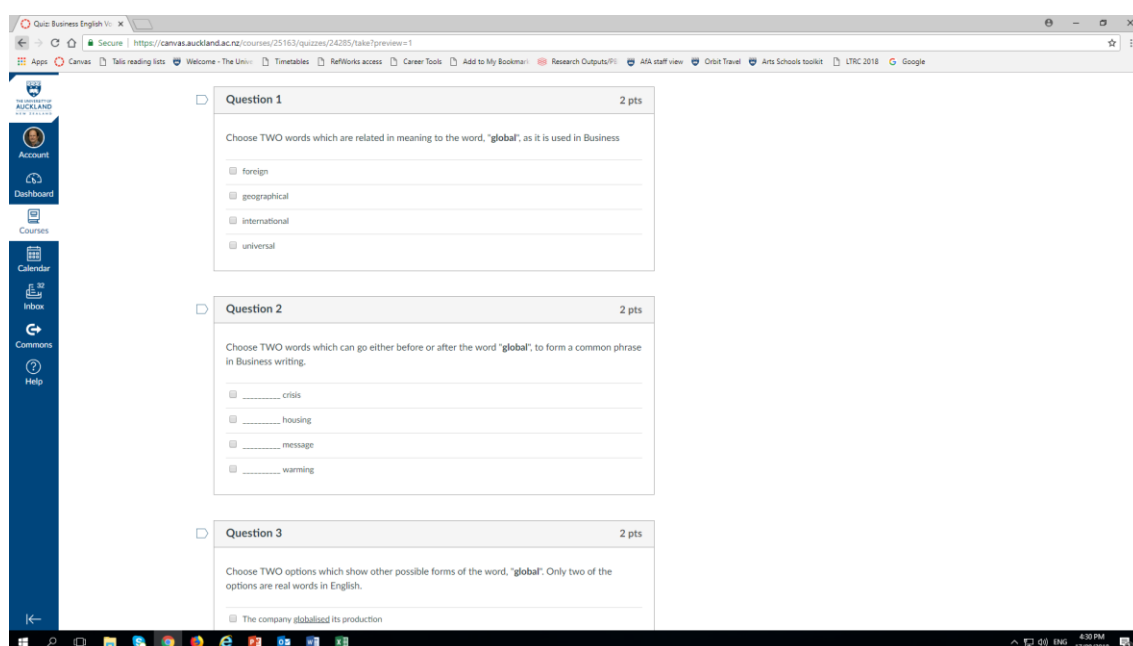

Figure 3. A screenshot of the online version of the Business English Vocabulary Test

II.2 A Test of Academic Vocabulary

The second project on testing depth of vocabulary knowledge has been conducted in collaboration with Dr Yen Dang at Vietnam National University in Hanoi. The goal here was to develop a test of high-frequency academic vocabulary in English, following the design principles of the Business English Vocabulary Test. The target population in this case are undergraduate students undertaking degrees in various disciplines through the medium of English. However, their English vocabulary knowledge is low: the majority have a secure knowledge of only the 1st 1000 words; few know more than small numbers of words beyond the 2000 word level. Apart from acquiring technical terms in their disciplines, it is unrealistic for them to expand their general vocabulary size while they are studying. Thus, the argument is that they need to know high-frequency academic words well to make the best of their limited vocabulary size.

For this project we did not create our own corpus, but rather worked with the Academic Vocabulary List (AVL) created by Gardner and Davies (2014), based a 120 million word

academic sub-corpus of the Corpus of Contemporary American English (COCA). This is a much larger and more comprehensive corpus of academic English than the one used by Coxhead (2000) to compile the more widely known Academic Word List (AWL). The full Academic Vocabulary List comprises 3000 lemmas (a word in a particular part of speech, together with its inflected forms) – equivalent to 2000 word families. The 20 most frequent lemmas are *study* (noun), *group* (n.), *system* (n.), *social* (adj.), *provide* (verb), *however* (adv.), *research* (n.), *level* (n.), *result* (n.), *include* (v.), *important* (adj.), *process* (n.), *use* (n.), *development* (n.), *data* (n.), *information* (n.), *effect* (n.), *change* (n.), *table* (n.) and *policy* (n.). Clearly noun lemmas predominate among the high frequency items in the list. Note too that, unlike the AWL, the AVL does not exclude words that occur with high frequency in general English, provided that they meet the criteria of frequency, range and dispersion in the COCA academic corpus. Gardner and Davies have a web interface that allows users to explore the uses of particular words in the COCA academic corpus (www.wordandphrase.info/academic/frequencyList.asp). The interface provides frequency data (both overall and in particular disciplines), definitions, synonyms, common collocates, and multiple concordance lines.

In terms of design, the Academic Vocabulary Test was confined to the 200 most frequent AVL lemmas as target words, and almost all the vocabulary used in the test items came from the first 2000 word families in the BNC/COCA lists compiled by Nation (n.d.), in order to reduce the chances that the test-takers would encounter completely unknown words in the test. The item format was designed to include the same three components of word knowledge as the Business Vocabulary Test:

- A. Synonyms/words with related meanings
- B. Collocations
- C. Word family members

In Part A the items were based on the model of the word associates format, as in Figure 4:

In this part each item has one main word followed by four other words. Put a circle round the 7 words which are most closely related in meaning to the main word.

Examples

consider	think	discover	offer	believe
nation	programme	government	country	business

Figure 4. Sample items in Part A of the Academic Vocabulary Test

As much as possible, the associates were also high-frequency words in the AVL.

In Part B, after some initial trialling, the target words and their collocates were presented in a short phrase or sentence, based on actual examples from the concordance lines in the AVL online interface. This offered greater flexibility in presenting different types of collocations than the more limited item type used in the Business Vocabulary Test. Some

of the items were distractors: phrases or sentences which did not include a common collocation of the target word. A Yes/No/Not Sure response format was adopted, so that the test-takers were required to respond to every item, rather than just selecting those which they knew to be correct. Some sample items are given in Figure 5.

	Yes	No	Not Sure
a. a low level	✓		
b. to write an article	✓		
c. a closed difference		✓	
d. the process looks loud		✓	
e. the population grows each year	✓		

Figure 5. Sample items in Part B of the Academic Vocabulary Test

Part C, which tests knowledge of inflected and derived forms of the target word, is modelled on the same part in the Business Vocabulary Test, except for the Yes/No/Not Sure response format:

	Yes	No	Not sure
develop			
a. It is a new <u>development</u> .	✓		
b. They <u>developed</u> a new product.		✓	
c. She is the main <u>developer</u> of the program.	✓		

Figure 6. Sample items in Part C of the Academic Vocabulary Test

Earlier this year, the test was piloted with 221 students at Vietnam National University and we are currently analysing the results. As might be expected, the students obtained the highest scores on Part A (synonyms), followed by Part C (word family members). Identifying the correct collocations in Part B proved to be the most difficult task in the test, confirming the common observation that collocations are challenging, even for advanced learners. In the pilot study, the participants also took the updated Vocabulary Levels Test (Webb, Sasao & Balance, 2017) as a measure of their vocabulary size. The correlation between the scores on the two tests was .64, which provides some evidence that the Academic Vocabulary Test is not just testing vocabulary size but assesses other aspects of word knowledge as well.

In summing up these two studies of depth of vocabulary knowledge, I want to highlight the advances that have been made since I undertook my original work on the word associates format in the early 1990s. First, much larger computer corpora are now available, giving more reliable information on the frequency of words in general and in particular registers, subjects and areas of usage. Secondly, as demonstrated by the Business vocabulary project, it is possible to create smaller, more specialised corpora for specific assessment purposes. With both types of corpora we have tools like #LancsBox and the AVL interface that assist us in searching for evidence on typical collocations and patterns of meanings and usage for

the target words in a vocabulary test. However, it is important to emphasise that such tools provide the basis for better-informed judgements about how to write vocabulary test items; they do not allow for automated item writing. In particular, the online tools give only indirect guidance on which words and phrases will work effectively as distractors or as incorrect forms for collocational and word family test items. In addition, computer-based testing imposes some constraints on the types of item format that can be used.

III. MEASURING SPEED OF LEXICAL ACCESS

Let us move on to the second topic. One new dimension of vocabulary that can be measured by computer technology is speed of access to known words in the brain. Up until now timing of responses has not been part of L2 vocabulary testing – or indeed tests of other aspects of language ability. The concept of a speeded test, in which test-takers must respond as quickly as possible under a strict time constraint, has not played much role in language testing, and some authors (e.g. Purpura, 2004) have argued that it is not an appropriate way to assess learners' language knowledge. The normal practice is to score test items on the basis of whether the response is accurate or not, with sufficient time allowed for the test-takers to be able to respond to all the test items.

However, if we are interested in whether learners can employ their knowledge effectively for communicative purposes – whether it be receptively in reading or listening tasks, or productively in speaking or writing – it makes sense to measure whether they can retrieve word meanings or word forms instantly without conscious thought. This is the essence of what Ellis (2005) refers to as implicit language knowledge. If learners lack fluency in performing language use tasks, one reason may be that their overall vocabulary size is small, but another possibility is that they are slow to recall the words that they have studied explicitly. Thus, the argument is that a test of speed of access can have diagnostic value and may also motivate learners to develop more implicit knowledge of vocabulary.

One pioneering study of the role of response speed was undertaken by Laufer and Nation (2001), who adapted Nation's Vocabulary Levels Test (VLT) for computer delivery and measured how quickly the test-takers responded to the test items. The experiment included learners at three levels of proficiency and, as might be expected, those who were more proficient responded significantly faster than the less proficient learners. One interesting suggestion based on the findings was that, once the test-takers had demonstrated explicit mastery of the words at a particular frequency level, they needed some further learning time before they could increase their speed of response to those words. Among other limitations, the use of the VLT in this study meant that the test items had to be presented in sets of six words and three definitions (as in the paper-based VLT), and thus it was not possible to measure response times to individual items.

This limitation has been overcome in more recent studies by using tests with single items, and in particular the Yes/No format, which is the simplest method of assessing vocabulary knowledge. A test of this kind presents learners with a set of target words on the computer screen one by one and they simply respond Yes or No, according to whether they know the meaning of the word or not. Since its introduction into L2 testing by Meara and Buxton (1987), the format has been used extensively as a practical method of obtaining an estimate

of learners' vocabulary size, especially for placement purposes. To control for overestimation of knowledge, the items include a percentage of pseudowords so that a test-taker's score can be adjusted downwards if they respond Yes to a number of these non-words.

Some studies to measure the reaction times (RTs) to Yes/No vocabulary items have produced mixed results (Miralpeix & Meara, 2014; Pellicer-Sánchez & Schmitt, 2012). However, Michael Harrington at the University of Queensland, together with his research associates, has conducted a substantial amount of research with what he calls Timed Yes No (TYN) tests in language schools and universities in Australia, Oman and Singapore (Harrington, 2018). These studies have set out to investigate the extent to which speed of response, as measured by RTs, can add to accuracy scores as predictors of the performance of L2 learners in English language programmes, particularly students preparing for English-medium university study. The findings have consistently shown that, while accuracy scores are the best predictors of the various criterion measures, mean reaction time adds significantly to the predictive power of a TYN test. This has led Harrington to propose the construct of lexical facility, defined as "the capacity to recognize words quickly. It combines vocabulary knowledge, as manifested by vocabulary size, with the processing skill needed to access these words" (2018, p. 68).

Harrington has acknowledged some limitations of the research related to the Yes/No test format that he has used. Learners respond differently to the task, particularly in the extent to which they give Yes answers to pseudowords, which are known as "false alarms". Numerous authors have discussed ways to score the test to take account of this kind of response behaviour (see, eg, Huibregtse, Admiraal & Meara, 2004). However, after extensive research with learners of French in a Belgian University, Eyckmans (2004) concluded it was simply not possible to obtain a valid measure of their vocabulary size with a Yes/No test because of the high false alarm rate. Read and Shiotsu (2014) reported problems in analysing the English vocabulary scores of Japanese university students for a similar reason. The simplicity of the task may work against it, in the sense that test-takers may respond too quickly and inattentively, especially if they do not understand the point of the task and are not motivated to perform to the best of their ability.

Thus, the construct of lexical facility is an appealing one because of its potential as the basis for a diagnostic measure of how readily learners can access their vocabulary knowledge for functional purposes, and as an indirect measure of their language proficiency in a more general way. Computer-based tests allow reaction times to be measured precisely, as well as presenting the target words in a consistent and controlled manner on the screen. The Yes/No test may not be the most suitable format to use. In fact, Harrington (2018) discusses several other test tasks which could be explored as alternatives, but none of them stands out as superior at this stage. Nevertheless, there is scope for further research to see how reaction times and other measures of speed can be incorporated into the testing of vocabulary ability.

IV. LEXICAL MEASURES IN WRITING ASSESSMENT

I would also like to write briefly about vocabulary assessment that is more embedded, comprehensive and context-dependent. There is quite a long history in language teaching of applying lexical statistics to evaluate the quality of learners' writing. Read (2000, Chap. 7) reviewed a number of studies that used quantitative measures to assess lexical variation, lexical sophistication, lexical density and lexical errors. Lexical variation, which is now more commonly called lexical diversity, has traditionally been measured by the simple type-token ratio (the proportion of different words used), but there have been numerous efforts to devise a more robust statistic to overcome the influence of the length of the text (e.g. Malvern et al., 2004). More recently, the focus has shifted from ever more sophisticated quantitative analyses to exploring how the statistics can complement human judgements (Jarvis & Daller, 2013). For instance, Jarvis (2017) has conducted a series of studies to establish the reliability of language user perceptions of lexical diversity in texts and proposes a model that combines human judgements with objective measures to account for the range of vocabulary use in written texts. His work is related to corpus linguistics but has implications for the use of lexical statistics in language assessment.

Lexical diversity and other vocabulary measures figure prominently in Automated Writing Evaluation (AWE), the process of scoring writing scripts automatically by means of a computer algorithm. Automated Speaking Assessment is less advanced, particularly because of the difficulties for automated systems of recognising and processing a wide range of accents. (Suvorov & Hegelheimer, 2013; Xi, 2010). However, with written text computer processors can readily identify numerous lexical features in addition to lexical diversity: the number of words written; the average length of the words (in letters or syllables); the proportion of content words; the number of less frequent words; the number of identifiable collocations (since collocation lists are now available); the use of identifiable discourse markers (again, from an inputted list); and the occurrence of other relevant vocabulary, such as academic words, technical terms, and expressions that are specific to the topic of the writing. These systems can also analyse various grammatical features of the text. There have been great advances in the technology, and AWE is used operationally to score the writing of both first and second language users of English, having produced high correlations with human ratings of the same scripts. However, critics point out that this tends to lead to a focus on surface features of texts, at the expense of qualities like style, creativity and depth of thinking, which only human raters can evaluate (Cotos, 2011). Thus, although computer analysis of the vocabulary of a text can be easily done and is very informative, there are larger issues at stake concerning the validity of such an assessment. As Douglas (2000, (p. 119) put it, "the question remains of whether there are aspects of language production that humans are sensitive to and that computers do not recognise".

Bearing this in mind, there is interesting variation in the policies on AWE among the three major international English language proficiency tests. The International English Language Testing System (IELTS) is still primarily a paper-based test, although a computer-based test is currently being rolled out as an option for candidates. The two IELTS writing tasks by each candidate are marked separately by human examiners, and Lexical Resource is one of the four criteria that they apply to the rating of the scripts. In the case of the internet-based Test of English as a Foreign Language (iBT), the test is administered on computer

to most candidates, but the scoring is a combination of at least one human rating and one automated score using the ETS e-rater system. This can be seen as representing “the best of both worlds”: highly reliable and efficient scoring of the lexical and grammatical features of the text, together with human judgements of the quality of the writing in a broader sense. The third test, the Pearson Test of English (Academic) features both computer administration and fully automated scoring of both writing and speaking tasks. The trade-off in this case is that the writing and speaking output that the candidate produces is quite constrained, in order to overcome the limitations of the automated scoring system.

V. CONCLUSION

In this brief overview of vocabulary assessment in the digital era, I have pointed out various ways in which computer-based testing can greatly facilitate the processes of item writing, test administration and scoring but I have also pointed to ongoing constraints. Large computer corpora give us much better quality information about the frequency and uses of the vocabulary items that we wish to test, both individual words and larger multi-word units. On the other hand, the readily available computer systems to produce tests at the local level are limited in the range of item formats that they allow. We can feasibly obtain new measures from computer-based tests, such as the speed of response to individual items, but it remains to be seen whether valid tests of lexical access can be developed. And since vocabulary knowledge and use are such key components of performance in all kinds of language tests, lexical measures have a key role to play in the development of automated scoring systems. In all these cases, although the potential for computer-based assessment is enormous, there is an ongoing need for human engagement to ensure that the validity of language tests does not become confined to what automated systems will allow us to measure.

REFERENCES

- Cotos, E. (2011). Potential of automated writing evaluation feedback. *CALICO Journal*, 28(2), 420-459.
- Coxhead, A. (2000). A new academic word list. *TESOL Quarterly*, 34, 213-238.
- Douglas, D. (2010). *Understanding language testing*. London: Hodder Education.
- Eyckmans, J. (2004). *Measuring receptive vocabulary size: Reliability and validity of the Yes/No vocabulary test for French-speaking learners of Dutch*. Utrecht, The Netherlands: LOT. Retrieved from: https://www.lotpublications.nl/Documents/91_fulltext.pdf
- Ellis, R. (2005). Measuring implicit and explicit knowledge of a second language: A psychometric study. *Studies in Second Language Acquisition*, 27(2), 141-172.
- Gardner, D., & Davies, M. (2014). A new Academic Vocabulary List. *Applied Linguistics*, 35(3), 305-327.
- Harrington, M. (2018). *Lexical facility: Size, recognition speed and consistency as dimensions of second language vocabulary knowledge*. London: Palgrave Macmillan.
- Huibregste, I., Admiraal, W., & Meara, P. (2002). Scores on a yes-no test: Correction for guessing and response style. *Language Testing* 19, 227-245.
- Jarvis, S. (2017). Grounding lexical diversity in human judgments. *Language Testing*, 34(4), 537-553.
- Jarvis, S., & Daller, M. (Eds.) (2013). *Vocabulary knowledge: Human ratings and automated measures*. Amsterdam: John Benjamins.

- Laufer, B., & Nation, P. (2001). Passive vocabulary size and the speed of meaning recognition: Are they related? *EUROSLA Yearbook*, 1, 7-28.
- Malvern, D., Richards, B., Chipere, N., & Durán, P. (2004). *Lexical diversity and language development: Quantification and assessment*. Basingstoke: Palgrave Macmillan.
- Meara, P., & Buxton, B. (1987). An alternative to multiple choice vocabulary tests. *Language Testing*, 4(2), 142-154.
- Miralpeix, I., & Meara, P. (2014). Knowledge of the written form. In J. Milton & T. Fitzpatrick eds., *Dimensions of vocabulary knowledge* (pp. 30-44). Basingstoke: Palgrave Macmillan.
- Nation, I.S.P. (2013). *Learning vocabulary in another language* (2nd ed.). Cambridge: Cambridge University Press.
- Nation, I.S.P. (n.d.). The BNC/COCA headword lists. Retrieved from: <https://www.victoria.ac.nz/lals/about/staff/paul-nation#vocab-lists>.
- Pellicer-Sánchez, A., & Schmitt, N. (2012). Scoring Yes/No vocabulary tests: Reaction time vs. nonword approaches. *Language Testing*, 29(4), 489-509.
- Purpura, J. (2004). *Assessing grammar*. Cambridge: Cambridge University Press.
- Read, J. (1993). The development of a new measure of L2 vocabulary knowledge. *Language Testing* 10(3), 355-371.
- Read, J. (1998). Validating a test to measure depth of vocabulary knowledge. In A. Kunnan, ed., *Validation in language assessment* (pp. 41-60). Mahwah, NJ: Erlbaum.
- Read, J. (2000). *Assessing vocabulary*. Cambridge: Cambridge University Press.
- Read, J. (2004). Plumbing the depths: How should the construct of vocabulary knowledge be defined? In P. Bogaards & B. Laufer (Eds.), *Vocabulary in a second language: Selection, acquisition and testing* (pp. 209-227). Amsterdam: John Benjamins.
- Read, J. (2012). Piloting vocabulary tests. In G. Fulcher & F. Davidson (Eds.), *The Routledge handbook of language testing* (pp. 287-299). London: Routledge.
- Read, J., & Shiotsu, T. (2014). Evaluating the effects of false alarm rates and non-words on a Yes/No vocabulary test. Paper presented at the Language Testing Research Colloquium, Amsterdam, the Netherlands. July.
- Suvorov, R., & Hegelheimer, V. (2013). Computer-assisted language testing. In A.J. Kunnan (Ed.) *The companion to language assessment* (pp. 594-613). Chichester, UK: Wiley-Blackwell.
- Webb, S., Sasao, Y., & Balance, O. (2017). The updated Vocabulary Levels Test: Developing and validating two new forms of the VLT. *ITL – International Journal of Applied Linguistics*, 168(1), 33-69.
- Xi, X. (2010). (Ed.). Special issue on automated scoring of writing and speaking tests. *Language Testing*, 27 (3).
- Zhang, D., & Koda, K. (2017). Assessing L2 vocabulary depth with word associates format tests: Issues, findings, and suggestions. *Asian-Pacific Journal of Second and Foreign Language Education*, 2(1). Retrieved from: <https://ore.exeter.ac.uk/repository/handle/10871/28216>.

USING EYE TRACKING AND NEUROIMAGING IN LISTENING ASSESSMENT: UNDERSTANDING THE ROLE OF TEST METHODS

Vahid Aryadoust

National Institute of Education
Nanyang Technological University
NIE3-03-97, 1 Nanyang Walk, Singapore 637616

ABSTRACT

This goal of this paper is two-fold: firstly, it adopts a framework based on eye tracking to investigate the cognitive processes of listening test takers and, secondly, it investigates the effect of test methods using an advanced neuroimaging technique called functional near-infrared spectroscopy (fNIRS). The first study¹ sheds light on dynamics of attention and answering under two conditions: listening during the first play of the stimuli (test items) and listening during the second play of the stimuli. It is found that the amount of attention paid to the written stimuli is amenable to change over time and across the first and second plays. In addition, the second study² shows a significant amount of within-individual variation in listening under different conditions. It provides evidence that brain pathways such as dorsomedial prefrontal cortex subserve top-down processing in oral language comprehension.

Keywords: *assessment; eye tracking; listening comprehension; neuroimaging*

I. INTRODUCTION

The first goal of this study is to apply eye tracking to investigate the cognitive processes of listening test takers under two conditions: listening during the first play of the stimuli and listening during the second play of the stimuli. From the test design perspective, listening tests can be divided into two groups: post-listening performance (PLP)—where listeners can see the test items only after listening to the auditory stimuli—and while-listening performance (WLP)—where listeners have to read the test items, listen to the auditory stimuli, and choose/write the answer almost simultaneously. Research shows that the concurrent application of listening and reading along with answering test items in PLP listening tests can present a set of challenges such as engaging test takers in superficial listening processes (Field, 2009). The reason is that human memories have limited capacities for the concurrent processing of multiple information sources at once, and attention tends to drift and be divided as the number of stimuli rises. However, little research has been done to

¹ The first study was supported by the National Institute of Education of Nanyang Technological University [grant number = RI 2/16 VSA]

² This study was carried out collaboratively by Dr Vahid Aryadoust and Dr Chiao-Yi Wu of Nanyang Technological University.

investigate listeners' concurrent engagement with written stimuli (texts) and the effect of this simultaneity on listening processes particularly in WLP tests. Some eye-tracking studies suggest that while reading plays an important role in test takers' cognitive processes in WLP tests, it can result in cognitive overload due to the concurrent processing of visual with auditory stimuli (Underwood, Jebbett, & Roberts, 2004).

The second aim of the study is to investigate the brain pathways associated with listening comprehension under assessment conditions. We posit that for a test to be authentic, it has to activate the brain pathways in the brain that are associated with daily-life listening. These brain pathways execute two major processes in listening: lower-level processing (bottom-up processing) and higher-level processing (top-down processing where inferences are drawn based on world knowledge). The lower- and higher-order listening processes will be measured by using Functional Near-Infrared Spectroscopy (fNIRS), a new non-invasive portable technique to study brain activity. Based on previous research, we posit that top-down processing is associated with the dorsomedial prefrontal cortex (dmPFC) and the bottom-up processing is subserved by the anterior temporal lobe (aTL), the left inferior frontal gyrus (Broca's area) and the left posterior superior and middle temporal gyri (Hagoort & Indefrey, 2014). These postulations are based on neurocognitive research which has determined the brain pathways underlying discourse comprehension and its undergirding components (vocabulary and grammatical abilities) (Hagoort & Indefrey, 2014). This line of research associates significant roles to dmPFC in discourse comprehension (Ferstl, 2010) and aTL, the left inferior frontal gyrus, and the left posterior superior and middle temporal gyri in sentence comprehension (Friederici, 2011; Hagoort & Indefrey, 2014).

II. METHODS

Participants

Participants in the eye tracking study are 28 secondary school students and those in the neuroimaging study are 11 university students.

Instruments and Procedures

The eye tracking study uses an online listening test wherein the participants listened to several short monologues and answered 12 comprehension questions. Each monologue was played twice to the participants who were seated in front of a computer in a quiet classroom or computer lab. The Tobii X3-120 eye tracker was used to measure fixation counts and visit counts during the first and second plays of the listening test.

The second assessment instrument which was used in the fNIRS study comprises two short lecture comprehension tasks: one in which the participants listened and answered the questions simultaneously and one where they listened first and subsequently answered the questions. This design was formulated to explore the effect of test method effects on the brain pathways which are engaged in understanding oral discourse. The fNIRS system adopted is NIRSport and the software used is nirsLAB.

III. RESULTS AND DISCUSSIONS

Study 1: Eye Tracking

In the eye tracking study, we measured fixations on and visits to the areas of interests (AOIs), parts of the texts to which participants pay close attention. Time series were generated and visualized. Next, cross-correlation functions analysis was performed to explore the correlation between the time series. Figure 1 presents fixation counts (left) and visit counts (right) across the two listening plays. There are two general observations in the graphs. One is that the amount of attention, as measured by counts and visits, increases across the playtime as well as across pre-listening and while-listening stages. In other words, on average, the participants paid more attention to the written stimuli during listening in times one and two, but relatively less attention during the pre-listening stage in times one and two. The cross-correlation analysis of these time series showed that the observed difference are significant at $p < 0.05$.

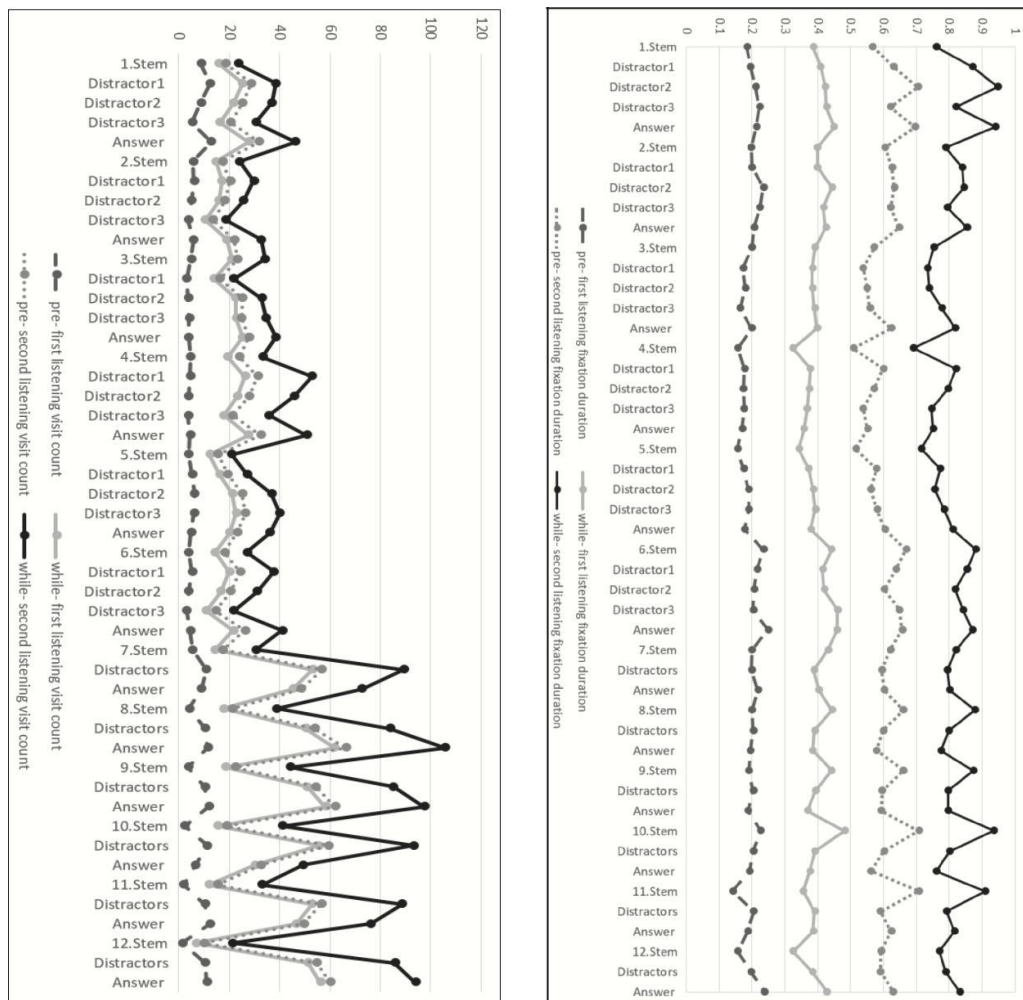

Figure 1. Average fixation count and visit count.

Study 2: Neuroimaging

The fNIRS study was carried out to provide further evidence to support the role of test methods. As previously stated, we presented the test items sequentially (after listening) and simultaneously (during listening). The data were pre-processed carefully and subjected to statistical parametric modeling (SPM) which is commonly used in neuroimaging research. We found significant within-individual differences during the two tasks. Figure 2 presents a schematic representation of the brain pathways which are engaged during the first and the second tasks. For participant 1, three main brain regions are more active during test 1 than during test 2: the dorsomedial prefrontal gyrus (top-down processing), the inferior frontal gyrus (bottom-up processing), and the posterior middle temporal gyrus (bottom-up processing). By contrast, the second task primarily engages a part of the inferior frontal gyrus which is associated with bottom-up processing, suggesting that, for participant 1, task 1 engaged relatively more top-down and bottom-up processing than does task 2.

By contrast, as Figure 3 demonstrates, participant 2 has an almost reverse brain activation pattern compared with participant 1, where task 2 engages the dorsomedial prefrontal gyrus (top-down processing) and a small region in the inferior frontal gyrus (bottom-up processing) and the posterior middle temporal gyrus (bottom-up processing). Accordingly, for this participant, task 2 functions like test 1 for participant 1, meaning that the tests have reverse activation patterns across the two participants. Similar patterns were found in other participants.

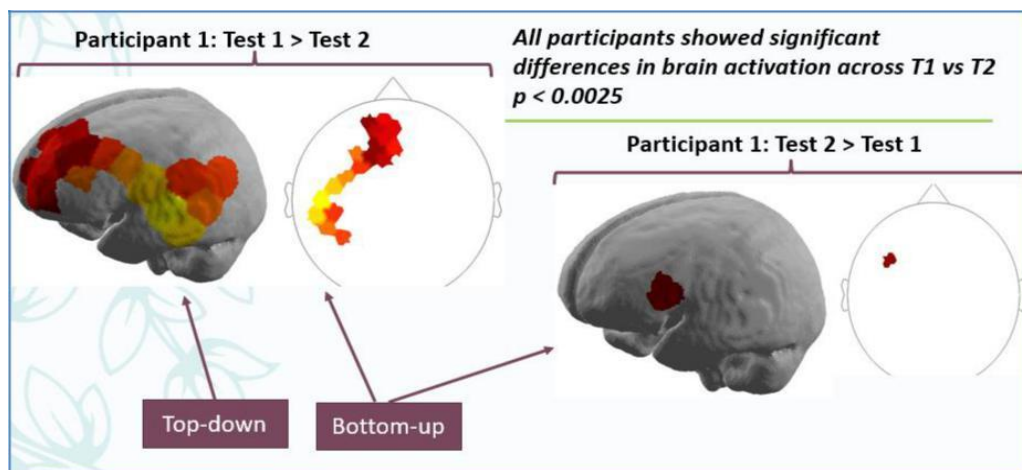

Figure 2. Within individual differences for participant 1.

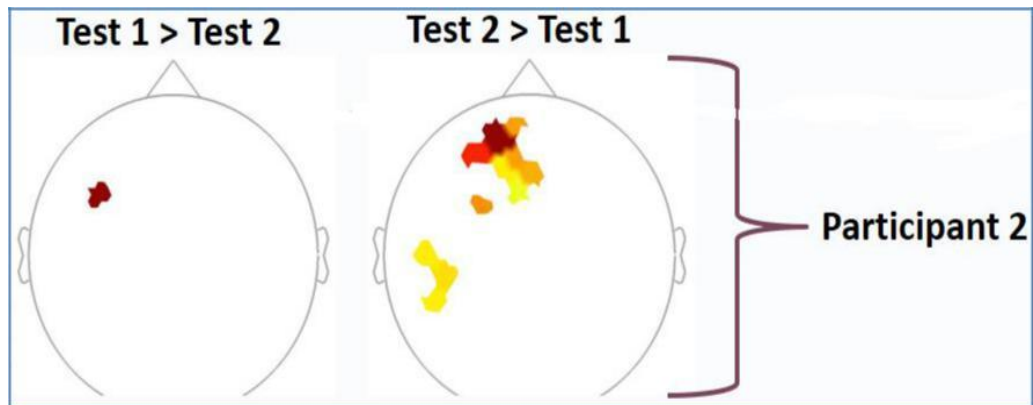

Figure 3. Within individual differences for participant 2.

IV. CONCLUSIONS AND SUGGESTIONS

This study set out to fulfil two goals: firstly, it applied eye tracking to investigate the cognitive processes of listening test takers and, secondly, it investigated the effect of test methods using an advanced neuroimaging technique called fNIRS. These methods were used to determine the effect of test methods on listening.

The first study found that test methods had a significant impact on the amount of attention paid to the test items. That is, the time when the test items are presented to test takers and the number of plays would affect the amount of attention paid to the written stimuli. We can infer that when listeners have to read test items and listen to the relevant stimuli, they have to divide the storage capacity of their working memory. Accordingly, paying attention to the written stimuli can compete for more working memory storage, thus affecting effectiveness and authenticity of the listening assessment (Field, 2013). It is suggested that listening tests should not engage listeners in simultaneous listening, reading, and answering, as this can affect the authenticity of the tasks adversely.

The second study investigated the brain pathways that subserve bottom-up and top-down processing in listening assessment. Within-individual SPM analysis showed significant differences across the participants. It was found that while task 1 engaged the dorsomedial prefrontal gyrus (top-down processing), the inferior frontal gyrus (bottom-up processing), and the posterior middle temporal gyrus (bottom-up processing) in some participants, task 2 only engaged the inferior frontal gyrus (bottom-up processing). This pattern reversed in other participants, suggesting a significant difference in the constructs that the tests measured. In sum, it can be said that, unlike the commonly adhered-to belief, listening assessments do not engage the same listening processes for different test takers. The concept of construct validity has been built upon the premise that the test engages the same construct across all participants, whereas our small-scale study clearly indicated that this might not be the case.

Future research should take into consideration the neurological evidence of validity and adopt eye tracking and neuroimaging technologies to determine the effect of assessment methods on listeners' neurocognitive processes. Our ongoing research at Nanyang Technological University aims to combine eye tracking and neuroimaging methods to identify the connections between attention as measured by fixation and visits, and the activation of the dorsomedial prefrontal gyrus (top-down processing), the inferior frontal gyrus (bottom-up processing), and the posterior middle temporal gyrus (bottom-up processing).

It is hoped the studies reported here have shed some light on some of the underresearched neurocognitive mechanisms in listening assessment.

REFERENCES

- Ferstl, E. C. (2010). Neuroimaging of text comprehension: Where are we now? *Italian Journal of Linguistics*, 22(1), 61-88.
- Field, J. (2012). The cognitive validity of the lecture listening section of the IELTS listening paper. In L. Taylor & C. Weir (Eds.), *IELTS collected papers 2: Research in reading and listening assessment*. Cambridge: Cambridge University Press.
- Friederici, A. D. (2011). The brain basis of language processing: From structure to function. *Physiological Reviews*, 91(4), 1357-1392.
- Hagoort, P., & Indefrey, P. (2014). The Neurobiology of language beyond single words. *Annual Review of Neuroscience*, 37(1), 347-362.
- Underwood, G., Jebbett, L., & Roberts, K. (2004). Inspecting pictures for information to verify a sentence: Eye movements in general encoding and in focused search. *The Quarterly Journal of Experimental Psychology*, 56, 165-182.

About the Author

Complete Name : Vahid Aryadoust
Institution : National Institute of Education, Nanyang Technological University
Email Address : vahid.aryadoust@nie.esu.sg
Education : PhD (applied linguistics)
Research Interest : Language assessment; eye tracking; neuroimaging

THE INFLUENCE OF BLOG WORDPRESS TOWARDS STUDENTS' WRITING ABILITY ON RECOUNT TEXT

Fitri Nur Asy-Syifa¹, Yudi Juniardi², John Pahamzah³, Delsa Miranty⁴

University of Sultan Ageng Tirtayasa^{1,2,3,4}

fitrinursyifa62@gmail.com¹

ABSTRACT

The objective of the research is to find out the influence of Blog Wordpress towards students' writing ability on recount text at tenth grade students of SMK Pasundan 1 Kota Serang. This research used quantitative approach through true experimental as a research design. The samples that used in this research were the students of X AK as the experimental group and X PM as the control group. For experimental group consisted of 32 students while in control group consisted of 29 students. So, the sample total was 61 students. The result showed that the average of total score in pre-test on control group was 62,13 became 67 on post-test. While on experimental group the average of total score in pre-test was 66,04 became 74,25. It showed that the gain score of experimental group was higher than control group. The result of t-test in this research also showed that t_{count} was higher than t_{table} ($3,502 > 2,021$). It means that the alternative hypothesis (h_a) was accepted. So, the researchers concluded that there is a significant influence of Blog Wordpress towards students' writing ability on recount text at tenth grade students of SMK Pasundan 1 Kota Serang in year academic of 2017/2018.

Keywords: *blog, wordpress, writing, recount text*

I. INTRODUCTION

Writing is one of the important skills that must be learnt by students in learning English as a foreign language. It can be useful in a working environment and education especially in academic purposes. Troike (2006:163) said that writing is the most important productive activity for L2 learners to develop if they will use the language for academic purposes or in certain types of service function. Thus, seeing how important writing is, students in Indonesia should also have good writing skill.

On the contrary, the students in Indonesia as L2 learners seem to always face the various problem. One of them was generated the structure of the words which make them hard to understand well how to have a good writing skill. It was because writing is a complex activity that needs a skill that not everybody cannot acquire that easy. It supported by Murray (2006:6) who stated that it complex activity because it involves starting, progressing and finishing a complicated and challenging combination of tasks. For example like choose the

right word to make a good sentence and then arrange it into a good paragraph. It requires to activate lots of different skills and orientations, sometimes at different stages and phases in the process, sometimes all at the same time.

The problems that the researchers mention above such as difficult of choosing the right word and make a proper paragraph of writing were also faced by students at tenth grade of SMK Pasundan 1 Kota Serang in year academic of 2017/2018. They had difficulties in completing writing task, such as confused how to express their ideas and thoughts into written text with good words. They also did not know how to start writing in a proper sentence and then arrange it into a good paragraph. Also they also have less interest in learning writing. Therefore, those problems made the students hard to have good writing skill.

A result of the problems above because of the teacher at SMK Pasundan 1 Kota Serang in year academic of 2017/2018 was tended to use lecturing method without involving any media in the classroom. It became one of the reasons why the students got bored and did not interest while learning English, especially when learning writing. Therefore, the researchers suggested using media in teaching learning because it contributed to the teaching and learning process. As Newby, Stepich, Lehman, Russell (2011: 100) said that media could serve or facilitate students learning the process. It can provide a stimulus-rich environment because they can provide vicarious experiences for students.

Considering the issues above, the purpose of this research was to use teaching media which could make their writing skill better. There are many kinds of media that can be used in teaching learning process and Blog Wordpress is one of them. Tandukklangi and Tahir (2015:2) said that Blog Wordpress is a tool to teach writing, notable and familiar technology in our area currently and it is never lost in the future, and that is why it will be interesting things and getting more in someday. Thus, the researchers would like to use Blog Wordpress in this research using recount text as the material because it made the students interested and it was also suitable with the syllabus. Other than that, from the the researchers' experiences in school, the teacher already taught them at a glance this material from the previous teacher even though this material should be introduced for the next semester, the researchers saw the result was still less.

Based on the background of the problem above, the researchers would like to propose the media to observe if there is any influence on students' writing ability on recount text through Blog Wordpress. The researchers only focused on personal recount text due to its many different genre and types in writing, besides that the material of recount text is suitable on the syllabus. Thus, the researchers conducted the research entitled "The Influence of Blog Wordpress Towards Students' Writing Ability on Recount Text at Tenth Grade Students of SMK Pasundan 1 Kota Serang in Year Academic of 2017/2018".

II. THEORETICAL FRAMEWORK

Many experts have proposed the definition and explanation of writing. Harmer (2007:86) said that writing is a process and we write is often heavily influenced by constraints of genres, and then these elements have to be present in learning activities. While Sokolik (2003) cited in Linse and Nunan (2005:98) said that writing is a combination of process and product which is the process refers to the act of gathering ideas and working with them until they are presented in a manner that is polished and comprehensible to readers.

On the contrary, the process of writing itself sometimes a little bit difficult to apply in learning activities. As Yakhontova (2003:41) said that writing is a difficult skill for native speakers and non-native speakers, researchers must balance multiple issues such as content, organization, purpose, audience, vocabulary, punctuation, and mechanics such as capitalization. It also pointed by Rijlaarsdam, Bergh and Couzijn (2005:153) who said that writing is a very complex activity because many processes occur at the same time like decisions on information, meaning construction, language formation, editing the product and constant monitoring of the process.

In short, it can be considered that writing is a cognitive process that influenced by constraint of genres. The process of applying it the researchers must balance the elements in order to have comprehensible writing to readers.

The blog is a media that we can use by using the internet to contribute to teaching-learning materials and discussions with students, especially in learning writing. As Karacapidilis (2010:162) said that Blog encourages writing and reflection. It could support an innovative, reflective learning style. Instant messaging, chat, online simulations, and portals represent other potential technologies to create active learning in online classes. While Campbell (2003:1) stated that a Blog could be thought of as an online journal that an individual can continuously update with his or her own words, ideas, and thoughts through software that enables one to do so easily. As Richardson (2010:10) defines Blog by saying that blog as they are known, are easily created, easily updatable websites that allow an author to publish instantly to the internet from any internet connection.

So, it can be concluded that Blog is a media technology or tool that embodies whoever want to write easily with using internet connection. It is like diary or journal based online, and everyone can access it anytime in everywhere.

III. METHODS

The research uses Blog Wordpress as media and focus on recount text on students' writing skill and used a quantitative method as research methodology with true experimental designs. In this research, the researchers used true experimental design because the researchers would like to know the effect of Blog Wordpress towards students writing ability on recount text with true experimental through two classes. Based on Creswell (2010:309) true experimental design comprises the most rigorous and strong experimental design because of equating the

groups through random assignment. The researchers divided the class into a control group and experimental group, the treatment only applied on experimental class while the control group does not. After the researchers get and investigate the result, the researchers compared the mean or the net scores to see if they are statistically similar between a control group and experimental group and relate them.

The researchers used true experimental design with non-randomized control group design because due to the time for this research was limited and the classification of the class in SMK Pasundan 1 Kota Serang had been determined by the school. It means that the researchers cannot change the classification of the group. So the researchers does not have accesses to full control the target. In this research, design chart can be seen in the figure below:

This research is conducted at SMK Pasundan 1 Kota Serang, which is located at Jl. Raya Jakarta KM.5 (Kec. Cipocok, Serang, Banten). The researchers researched the tenth-grade students of SMK Pasundan 1 Kota Serang in the second semester of academic year 2017/2018.

True experimental is concerned with knowing the effect of a variable (independent variable) to another variable (dependent variable). As explained by Creswell (2012:112), “variable is a characteristic or attribute of an individual or an organization that researcher can measure or observe and varies among individuals or organizations studied.” In this research, the researchers uses two variables as follow:

The populations of this research are the students of SMK Pasundan 1 Kota Serang at tenth grade in the second semester of academic year 2017/2018. The students divided into nine classes. The total of the population is 295 respondents.

The technique in collecting the data in this research was test. This research used pre-test before the treatment and post-test after the treatment to measure students’ writing recount text in order to see wether the test is valid and reliable or not. The data of this research was the score of the students’ writing ability in writing recount text that could be measured by using writing assessment from Brown (2004 : 244).

Based on the variable that took by the researchers, the researchers used tests as the research instrument by using a researcher-made test. As the variables of this research were Blog Wordpress as media to write recount text, so the test that gave to the students were written test. The students were asked to write a recount text. The test that gave by the researchers was pre-test before the treatment and post-test after the treatment. The test was given in order to measure the students’ writing skill in recount text wether the treatment is effective or not after the treatment.

IV. DISCUSSION

This research was conducted on April 22nd until May 5th 2018. It involved 29 students in the control class and 32 students in the experimental class, so the total sample was 61. The researchers only took 39 sample because there were only 15 students in the control class and 24 students in an experimental class who were attended in the pre-test and post-test. It was caused by some reason that will discuss below in detail from each class.

Control Class

The researchers conducted the first meeting in the control class on April 25th, 2018. In this first meeting, the students did a pre-test with a theme “My Holiday”. The pre-test was done to know their score or knowledge about recount text before the treatments. The result from pre-test in control class is one student #S. C.5 with the highest score was 76, one student #S. C.8 with the lowest score was 35, and the mean score was 62.13. The researchers found that most of them forget about the structure of recount text and lack in determining the idea and the concept of writing. In this first meeting, there were seven students who did not attend, one student was sick, and the other was absent.

Then, in the second meeting on April 26th, 2018, the researchers gave the students an explanation about the material of recount text. In this meeting, the students have 2 hours of learning English subject. So, in this meeting the researchers reviewed the students’ understanding of recount text and asked them to make recount text with a theme “My Best Moment”. In this meeting, the researchers saw the students’ interest less, and the class was hard to control stay focused on the material because of the students interrupted by another subject which has a lot of homework and project after English subject. The researchers also saw that the students’ understanding about the organization and structure of recount text were less.

After that, in the third meeting on May 2nd, 2018, the researchers still gave them the exercise to write recount text with theme “Embarrassing Moment”. In this meeting the researchers gave them more explanation about material especially focused on the organization of the structure and past tense in recount text because it still became their problem. Not only that, but the problem was also located on the event at that school, because the school would hold the graduation ceremony on May 7th, 2018. So, some of the students took the permission to not involved in the meeting for practising their own performance. But, because of the teaching time was limited on that day, most of the student still did not finish their exercise. So, the researchers made it as homework for them by giving the deadline in the next meeting.

So, in the fourth meeting on May 3rd, 2018 which was the last meeting, the researchers reviewed and discussed the homework from the last meeting because the researchers has 2 hours teaching time. Thus, the first hour discussed the students’ homework and then the next hour the researchers took the post-test with a theme “My Sad Moment”. The result from post-test in control class is one students #S. C.5 with the highest score was 78, three students #S.

C.1 #S. C.4 #S. C.8 with the lowest score was 60, and the mean score was 67. So, the researchers concludes that post-test showed a better score than pre-test, although there were not much of improvement.

Experimental Class

The researchers conducted the first meeting in the experimental class on April 24th, 2018. In this first meeting, the students have 2 hours of learning English subject. The first hour did a pre-test with a theme “My Holiday”. For the second hour, the researchers explained to them what they are going to do after pre-test, which was told them about Blog Wordpress and explained about material of recount text itself by showing them the the researchers’ Blog Wordpress. The pre-test was done to know their score or knowledge about recount text before the treatment. The result of pre-test in an experimental class is two students #S. E.5 #S. E.24 with the highest score was 82, one student #S. E.11 with the lowest score was 50, and the mean score was 66.04. Same with control class, the researchers found that most of them forget about the structure of recount text. The writing activity was also difficult for them, especially in arranging the idea and the concept of writing. In this first meeting, there were four students who did not attend, two students were sick, and the others were absent. The researchers assumed on those two students who did not attend because of the weather too. On that day, the weather was cold because of rain since early morning.

Then, in the second meeting on April 28th, 2018, the researchers gave the students the treatment by taking them to the laboratory. In this meeting, the students only have 1 hour of learning English subject. So, in this meeting the researchers reviewed the students’ understanding of recount text and asked the students to make their own Blog Wordpress based on the the researchers’ explanation in the first meeting after pre-test. After all of the students in experimental class made their own Blog Wordpress, then the researchers asked them to open the the researchers’ Blog and asked them to make their first post about recount text with theme “Embarrassing Moment”. Due to the time was not enough for them, the researchers told the students to save their writing as a draft in their Blog account. In this meeting, the researchers saw the students’ interest by using the media and different atmosphere of a place.

After that, in the third meeting on May 2nd, 2018, the researchers gave them the treatment on the laboratory. The last, in the fourth meeting on May 4th, 2018 which was the last meeting, the researchers took the post-test with a theme “My Sad Moment” and time allocation 1 hour. They showed the influence of using Blog Wordpress as media for teaching-learning in the classroom. It can be shown from the result of posttest in the experimental class is two students #S. E.18 #S. E.20 with the highest score was 88, two students #S. E.21 #S. E.23 the lowest score was 61, and the mean score was 74.25. So, the researchers concluded that the treatment was done successfully. It showed from the students’ score and can be seen from their interest and their awareness of their writing of past tense form, organization, mechanics and generic structure of the text. A result from this study indicated that Blog as media in teaching learning was effective for the students in learning writing recount text.

V. CONCLUSION

Based on the research findings in the previous chapter, the researchers found that there is an influence of using Blog Wordpress in students writing ability on recount text. The result shows that the students interest on writing recount text increase when they are using Blog Wordpress as the media for writing. Before the implementation of Blog Wordpress as the media in writing, the students never used interesting media to write. Thus, the researchers gave the treatment as a media in teaching learning. When the researchers introduced and demonstrated the use of Blog Wordpress in class, the students seemed enthusiastic and interested. Moreover, they paid attention to the researchers's explanation and they also asked some questions related to the recount text. The students followed the instructions given and they seemed serious in doing the tasks. Moreover, based on the findings of the study, the result of t-test showed that $t_{count} \geq t_{table}$ ($3.502 \geq 2.021$). It means that the null hypothesis was rejected and there was influence of using Blog Wordpress as media in teaching learning. It can be concluded that during the previous meeting with the researchers in Teacher Pre-Service Programs, many students were still not interest to write. As a result, their writing score was low in pre-test. Then, the implementation of Blog Wordpress as the media to write was effective to improve the students' interest in writing recount texts. It indicated that the using of Blog Wordpress as media influenced students' writing ability at tenth-grade students of SMK Pasundan 1 Kota Serang.

REFERENCES

- Ary, D. Jacobs, L.C. Sorensen, C. and Razavieh, A. (Eight Edition). (2010). Introduction to Research in Education. Belmont, CA, USA: Wadsworth Cengage Learning.
- Balnaves, M. and Caputi, P. (2001). Introduction to Quantitative Research Methods: An Investigative Approach. Great Britain: The Cronwell Press Ltd.
- Brown, H.D. (2003). Language assessment: Principles and Classroom Practices. Longman
- Campbell, A.P. (2003). Weblog for Use with ESL Classes. p.2 (Retrieved on January 26th, 2018 from <http://iteslj.org/Techniques/Campbell-Weblogs.html>)
- Creswell, J.W. (Fourth Edition). (2010). Educational Research: Planning, Conducting and Evaluating Quantitative and Qualitative Research. Boston: Pearson Press, Edwards Brother, Inc and Phoenix Color Corp.
- Department of Education and Communities. 2011. School A to Z. State of NSW
- Hatch, E. and Farhady, H. 1982. Research Design and Statistics for Applied Linguistic. Massachusetts: Newbury House Publisher, Inc.
- Hatch, E. and Lazaraton, A. (1991). The Research Manual: Design and Statistics for Applied Linguistics. New York: Newbury House Publishers.
- Foster, J.J. 2002. Data Analysis Using SPSS for Window Version 8 10: A Beginner's Guide. Great Britain: The Cronwell Press Ltd.
- Gravett, S. and Rensburg, W.V. (Second Edition). 2005. Finding Your Way in Academic Writing. Cape Town: Creda Communications
- Harmer, J. 2007. How to Teach Writing. Essex: Longman
- Hyland, K. (Second Edition). 2009. Teaching and Researching Writing. United Kingdom: Pearson Press

- Hyland, K. 2004. *Second Language Writing*. United States of America, New York: Cambridge University Press.
- Juniardi, Y. and Samanhudi, U. 2006. *Teaching Argumentative Writing Through Weblog*. p.1 (Retrieved on March, 7th 2018 at 16:49 P.M from www.google-scholar.com)
- Karacapidilis, N. 2010. *Web-based Learning Solutions for Communities of Practice*. University of Patras, Greece. United States of America: Information Science Reference (an imprint of IGI Global)
- Knapp, P. And Watkins, M. 2005. *Genre, Text, Grammar: Technologies for Teaching and Assessing Writing*. Australia: Everbest Printing
- Linse, C and Nunan, D. (2005). *Practical English Language Teaching: Young Learners*. New York: McGraw-Hill Companies, Inc.
- Murray, R. and Moore, S. 2006. *The Handbook of Academic Writing: A Freshman Approach*. Berkshire, England: Open University Press
- Newby, T.J. Stepich, D. Russell, J.D. 2011. *Educational Technology for Teaching and Learning (4th Edition)*. Pearson Press
- Richardson, W. (2010). *Blogs, Wikis, Podcasts, and Other Powerful Web Tools for Classrooms*. Thousand Oaks, CA, New York: Corwin Press.
- Rijlaasdarm, G. Bergh, H.V.D. Couzijn, M. (2005). *Effective Learning and Teaching of Writing A Handbook of Writing in Education Second Edition*. Boston, USA: Kluwer Academic Publishers
- Scott, D. and Morrison, M. 2006. *Key Ideas in Educational Research*. Great Britan: Antony Rowe Ltd, Chippenham, Wiltshire.
- Tandukklangi, A.S. and Tahir, K. 2013. *Using Web Blog to Teach Personal Recount Text*. p. 1365-1370 (Retrieved on November, 2nd 2017 at 21:14 PM from www.ijsr.net)
- Troike, S.M. 2006. *Introducing Second Language Acquisition*. New York : Cambridge University Press.
- University of Canberra. 2011. *UC Highschool Kaleen Writing Handbook*, Canberra, Australia: University of Canberra Press
- Weigle, S.C.2009. *Assessing Writing*. United Kingdom: Cambridge University Press.
- Yakhontova, T.V. 2003. *English Academic Writing: For Students and Researcher*. Bureau: Academic Council of the Ivan Franko National University Press.

TINKERBEL: THE BLOOM-ANDERSON-KRATHWOHL'S COGNITIVE LEVELS AND K 13 TEXT BASED ENGLISH TEACHING IN VOCATIONAL SCHOOLS

Nina Fatriana

SMKN 2 Kalianda South Lampung

nf2956@gmail.com

ABSTRACT

The national Examination items are now notorious among vocational school English teachers and students due to their 'HOTS' labels and the great failures suffered by the schools. This higher order thinking skill notion becomes the major concern in the aspect of 2013 curriculum language teaching assessment. The fact that the revised K13 implements the text based English teaching requires Vocational School English teachers to be aware of the 'TINKERBEL' or the Bloom-Anderson-Krathwohl's cognitive levels applied not only in the assessment stage but more also in the process. This paper proposes alternative solution for vocational School English Teachers to adapt with the curriculum much more conveniently through the interface of the syllabus with the Bloom-Anderson-Krathwohl's cognitive levels and the approaches of dealing with texts: TAVI (text as a vehicle of information), TALO (text as a linguistic object), and TASP (text as a springboard for production) as far as the teachers are creative and industrious.

Keywords: *cognitive levels, HOTS, TAVI, TALO, TASP.*

I. INTRODUCTION

In the last National Examination for Senior High Schools (SMA/MA/SMK) which took place from 9 to 12 of April 2018, there were as many as 1.812.565 students all over Indonesia taking parts in it. However, the end result was not very satisfying due to the increased rate of item difficulty on the test materials. The consequence was that our Minister of Education personal Instagram account was bombarded with complaints, absurd condemnments and anecdotes. In response to those complaints, the minister himself then explained that the rate of item difficulty was actually shifted from the former LOTS and MOTS items (lower order thinking skill and medium order thinking skill) to the latter HOTS (higher order thinking skill) items which require the test takers to perform their reasoning skills. This was aimed at provisioning the SMA//MA/SMK graduates with the 21st century skills so called as the 7 C's, namely the Critical thinking and doing, Creativity, Communication, Collaboration, Career and Learning Self Reliance, Cross Cultural Understanding, and Computer and ICT literacy. It is the first C, the Critical Thinking and Doing skill where this HOTS business belongs to.

Actually this shift had already been introduced by the Ministry of National Education through its decrees, namely the Permendikbud number 20, in 2016 for the standard competency based for SMA/SMK graduates, number 21 for the standard of content for SMA/SMK curriculum, number 22 for the standard of education process, number 23 for the standard of evaluation, and number 24 for the list of basic competences on various

field of studies which had been revised later. Particularly for the SMK major basic competences, they were regulated in the letter of decree issued by the Director of Vocational Education number 330, in 2017. Yet, this regulation has not been socialized well through out the schools in Indonesia because of many factors regardless of the ministry's efforts to train teachers all over Indonesia about the 2013 curriculum and the revised 2013 curriculum wave after wave, batch after batch up to 2018. It was probably because of the wide area coverage in the 34 provinces of our country, the ignorance among the teachers themselves, as well as the teachers' limited proficiency and mastery on the aspects of the new curriculum. As a result, when the HOTS contents were tested in the previous 2018 National Examination, many schools, teachers and students were NOT ready and the result was devastated!

As a matter of fact, the currently revised 2013 curriculum changed the trend of English teaching in Indonesia into 'Text Based English Teaching'. There is no difference between General Senior High School (SMA) and Vocational High School (SMK) English curriculum in terms of content. Students of both schools are introduced with various genres and the structures of texts, their social functions and their language elements. Texts types are given based on the pattern of interaction in the society such as the monologue text, interpersonal texts, short functional texts, and transactional texts. Further, the delivery of the lesson should use the scientific approach that involves observing, questioning, collecting information, associating, and communicating, with some choices of learning models like discovery, inquiry, problem based and project based learnings. The materials given should also be graded into factual, conceptual, procedural and metacognitive dimensions, and there are more specific aspects on evaluation so that all materials, methods and tests must fit with the HOTS or High Order Thinking Skills circumstances.

The constant changing of curriculum is the consequence of the changing posts and policies at the ministry level. It truly results in dilemma for English teachers, especially SMK English teachers. It has been and will take time to master, adjust and implement the new versions of the curriculum in the classroom. The commonly shared anecdote of this condition among teachers is 'no matter what, throw away the old one and grab the new one!' It means the previous curriculum was not appropriately and comprehensively implemented, yet teachers must familiarize and implement the new curriculum abruptly as the front liners of education.

Actually, there is an alternative effort to enable SMK English teachers to adjust with this unstable state of English curriculum. Providing that the changing curriculum is still a text based one, SMK English teachers can interface *the ways in viewing the texts*: the TALO (text as linguistics object), TAVI (text as a vehicle of information), and TASP (text as a springboard for production) *with the latest version of K 13 English curriculum and the Bloom-Anderson-Krathwohl's cognitive levels*. With those, It is highly expected that they can adjust, master and design lessons that provision their students with English skills as well as the the 21st century life skills. This paper will discuss about one effort to nurture the TINKERBEL (tingkatan ketrampilan berpikir logis LOTS, MOTS, HOTS) by designing the learning model with the interface of the three elements

mentioned above so that the students will gradually develop their HOTS and can do well with HOTS items in National Examination.

II. DISCUSSION

HOTS and The Bloom-Anderson-Krathwohl's Cognitive Levels

As required in the revised 2013 curriculum, teachers and educators in Indonesia need to comprehend the learning taxonomies and the new forms of course objectives such as the Bloom Taxonomy (1956), the SOLO taxonomy by Biggs and Collis (1982), the creative problem solving taxonomy by Krulik and Rudnick (1998), the learning, teaching and evaluating taxonomy as the revised version of Bloom's taxonomy by Anderson and Krathwohl (2001). Picture 2.1 shows the revised version of Bloom-Anderson-Krathwohl's cognitive levels or TINKERBEL (tingkatan ketrampilan berfikir logis).



Figure 2.1 Bloom- Anderson-Krathwohl's Cognitive Levels

HOTS or higher order thinking skill is the higher cognitive levels which are developed from various cognitive concepts, methods and learning taxonomies. The main objective of empowering the HOTS in the curriculum is to improve the students' cognitive skills to reach the higher levels particularly those connected with critical thinking in processing various kinds of information they get, with creative thinking in solving various problems by making use of the knowledge they get, as well as with decision making over the given complex 21st century situations as seen on table 2.1 below:

Table 2.1 The Basic Concepts of HOTS

Problem Solving Krulik & Rudnick (1998)	Original Bloom Taxonomy (1956)	Revised Bloom- Anderson- Krathwohl's	HOTS Higher Order Thinking Skill
---	--------------------------------------	--	--

Taxonomy (2001)			
Recal (Basic)	Knowlede Comprehension Application	Remember Understand Apply	
Critical (Creative)	Analysis Synthesis Evaluation	Analyze Evaluate Create	Critical Thinking Creative Thinking Problem Solving Decision Making

Text Based English Teaching

According to Mickan (2006), texts are part of our social environments and human relationships, so learners are attuned to recognition of texts, to working with texts, and to learning with texts, and they expect texts to make meaning. The aim of teaching is to immerse students in experiences with texts in order to reflect the richness of students' everyday experiences of texts. The teacher's role is to select and sequence texts for planned and direct instruction for a class to learn the texts for participation in the class community and the community they aspire to beyond schooling. Programming involves selection of texts for students' participation in targeted language practices specific to students' purposes for learning the language. The main idea is for students to work to understand relevant texts, to respond to texts, and to express meanings in texts. The activities based on texts include observing texts in action, reacting to texts, analyzing texts, and composing texts. Consequently, this text based English teaching potentially will support the provisioning of HOTS as the 21st century life skills viewed from the combination of the learning, teaching and evaluating taxonomy with the dimensions of knowledge merged by Anderson and Krathwohl (2001) and with approaches to text (TALO,TAVI,TASP) as seen on table 2.2 :

Table 2.2 Anderson and Kartwohl's Taxonomy with Dimensions of Knowledge and Approaches to Texts (TALO,TAVI,TASP)

Anderson Krathwohl's Taksonomy of Learning, Teaching and Evaluating	Anderson dan Krathwohl's Dimension of Knowledge			
	Factual Knowledge	Conceptual knowledge	Procedural knowledge	Metacognitive knowledge
Remember Understand Apply				
Analyze Evaluate Create	HOTS (Higher Order Thinking Skills) TALO, TAVI,TASP			

Based on table 2.2, it can be seen that HOTS can be trained and implemented by referring to activities such as analysing, evaluating and creating the knowledge that the students do in their text learning experience adjusted to dimension of knowledge~ the factual, conceptual, procedural and metacognitive ones. Thus, TAVI and TALO might train them the analyzing and evaluating skills, while TASP for the Creating one.

How English Teachers View Texts

In language teaching literature TALO, TAVI and TASP are three acronyms that have been used to describe texts (John and Davis, 1983). Indonesian English teachers should be familiar with these approaches in viewing texts, so that whenever the curriculum changes, they can just interface the new versions of basic competences listed in the curriculum with the typical text lessons outlined on TAVI, TALO or TASP approaches, then they can adjust them with their lesson plans.

TALO stands for text as a linguistic object. TALO text is used for language work specifically grammar or vocabulary. TALO texts are written especially with a pedagogical purpose in mind. They could be authentic texts the teacher has chosen because they contain lots of examples of a particular feature of language. They could be authentic texts "adapted" to contain or highlight certain features of language. Some sample of TALO activities are: finding all the examples of X in a text (for example, a grammar pattern, function words, a particular verb form...), finding all the words in the text that are connected to X (words that are topically linked, or lexical sets), and deciding why certain forms were chosen over others (why was a conditional used, for example).

TAVI stands for text as a vehicle for information. A TAVI text has a different focus. Information within the text is seen as more important than the language. Students should understand the overall meaning of a text instead of (or at least before) the finer points of detail. TAVI texts can be chosen because they are motivating. They can be ones that the teacher would hope the students would like to read anyway. They can be authentic texts. TAVI type activities include: predicting the content of the text, discussing questions or statements that relate to the text, giving paragraph or section headings, marking things in the text that you knew/didn't know before, answering comprehension questions, summarising the main points of a text, and putting events in order.

TASP stands for text as a springboard for production. Another acronym is text as a stimulus for production. This means using a text as a springboard for another task - usually a speaking or writing task. TASP approaches also fit well with the communicative approach. TASP type activities could be :doing a role play or real play based on the text, discussing issues raised by the text, having a debate about the points of view presented in the text, writing a similar text about something the students know about, and writing a response to the text.

Planning a Typical Text Lesson in the 21st Century.

Our children, our country's next golden generation in the year 2045, will not be able to win the tight competition in that era if they currently are not trained with the 21st century life skills such as comparing, evaluating data, thinking critically, drawing conclusion, solving problems and applying their knowledge on the real life contexts as well as adapting with the brand new situation. Hence, this results in challenges, requirements, and needs in Indonesian education development. We should provision students on every level of education with the qualified character building, basic literacy, and the 7 C's competences (critical thinking, creativity, communication, collaboration, career and learning self reliance, cross cultural understanding, and Computer and ICT literacy, just as elaborated by the Partnership for 21st Century Skills Institution (2008:9).

Now the thing is, how can teachers 'get the most' out of a text in the 21st century? One way is to combine the different approaches (Verster,2005) . So, a text lesson from start to finish would be:

- a. Choose a text that we think will be interesting and motivating for our students but not too hard (TASE: text as a source of enjoyment). Do this with the information content in mind, not just the language in mind (i.e. TAVI). Design activities that will help students process this information and understand the text.
- b. Look for particular grammar or vocabulary that is worthy of mention in the text and design activities that can bring that out.
- c. Think of what kind of task the students could do once they've finished with the text.
- d. In class, start with TAVI-type activities, so that the students understand the information in the text.
- e. Then look at the language in the text in closer detail, through TALO-type activities.
- f. Finally, close the lesson off with a TASP activity.

Interfacing the Revised K13 English Curriculum for Grade 10 of Vocational School with the TINKERBEL and the 'TALO, TAVI and TASP' Ways of Viewing Texts

Contrary to the common facts practiced by most English teachers in Indonesia,(i.e. they rely on text books instead of syllabus) English teachers in Indonesia should always refer to the syllabus before designing the learning experiences because it gives freedom in designing the learning activities and materials (unlike the limited ready to use ones in the text books). This way, english teachers can interface the basic competences listed on the new curriculum with the TINKERBEL and the three approaches and designated text lessons (TAVI,TALO and TASP). Table 2.3 shows the examples of four alternative interfaces (due to limitation of words, the twelve basic competences alternative interfaces would not be shown all).

Table 2.3 The Interface of English K13 Curriculum For Grade 10 of SMK with TINKERBEL and TAVI, TALO and TASP Approaches

No	Basic Competences of the Revised English K13 for Grade 10 of SMK	Approaches and Designated Text Lessons
1	<p>3.1. Menganalisis fungsi sosial, struktur teks, dan unsur kebahasaan teks interaksi transaksional lisan dan tulis yang melibatkan tindakan memberi dan meminta informasi terkait jati diri dan hubungan keluarga, sesuai dengan konteks penggunaannya. (Perhatikan unsur kebahasaan <i>pronoun: subjective, objective, possessive</i>) Menangkap makna pemaparan jati diri lisan dan tulis.</p> <p>4.1 Menyusun teks interaksi transaksional lisan dan tulis pendek dan sederhana yang melibatkan tindakan memberi dan meminta informasi terkait jati diri, dengan memperhatikan fungsi sosial, struktur teks, dan unsur kebahasaan yang benar dan sesuai konteks penggunaannya</p>	<p>1. TAVI :</p> <ul style="list-style-type: none"> a. Reading a dialog about introduction, answering comprehension questions b. Reading and arranging jumbled paragraph about family tree. <p>2. TALO :</p> <ul style="list-style-type: none"> a. Identifying expressions about self introduction such as name, address, job, hobby, favorites, zodiac, place and date of birth, etc b. Matching the proper pronouns with the texts given. <p>3. TASP :</p> <ul style="list-style-type: none"> a. Speaking, circle- in circle out activities of self introduction b. Writing, drawing each own family tree and writing paragraph on it c. Speaking, to be presented in front the class with power point and pictures.
2	<p>3.2. Menganalisis fungsi sosial, struktur teks, dan unsur kebahasaan teks interaksi interpersonal lisan dan tulis yang melibatkan tindakan memberikan ucapan selamat bersayap (<i>extended</i>), dan responnya, sesuai dengan konteks penggunaannya.</p> <p>4.2 Menyusun teks interaksi interpersonal lisan dan tulis sederhana yang melibatkan tindakan memberikan ucapan selamat bersayap (<i>extended</i>), dan responnya dengan memperhatikan fungsi sosial, struktur teks, dan unsur kebahasaan yang benar dan sesuai kontek</p>	<p>1.TAVI :</p> <ul style="list-style-type: none"> a. Reading dialog about congratulating someone on his academic achievement b. Answering comprehension questions; c. Discussing on various achievements that people ususally congratulate others such as academic, sports, arts, new jobs, new relationship, newborn babies, new positions etc; <p>2.TALO:</p> <ul style="list-style-type: none"> a. Identifying some expressions to congratulate others found in the text. b. Analyzing the lexico grammatical aspects of the expressions. <p>3.TASP :</p> <ul style="list-style-type: none"> a. Pair work, writing, creating dialog of congratulating other

	<p>on a chosen achievement, b. Speaking , performing the dialog.</p>
<p>3 3.3 Menganalisis fungsi sosial, struktur teks, dan unsur kebahasaan teks interaksi transaksional lisan dan tulis yang melibatkan tindakan memberi dan meminta informasi terkait niat melakukan suatu tindakan/kegiatan, sesuai dengan konteks penggunaannya. (Perhatikan unsur kebahasaan <i>be going to, would like to</i>)</p> <p>4.3 Menyusun teks interaksi transaksional lisan dan tulis pendek dan sederhana yang melibatkan tindakan memberi dan meminta informasi terkait niat melakukan suatu tindakan/kegiatan, dengan memperhatikan fungsi sosial, struktur teks, dan unsur kebahasaan yang benar dan sesuai konteks penggunaannya.</p>	<p>1.TAVI:</p> <ol style="list-style-type: none"> Reading a dialog about planning for holiday vacation next Desember. Reading a passage about what people will do to plan holiday travel by using virtual applications. Answering comprehension questions. Discussing what students knew and don't know about planning holiday travel on line such as booking on line tickets, hotels, and restaurants. <p>2.TALO:</p> <ol style="list-style-type: none"> Group work, finding as many expressions of making plans as possible in the dialog (will, be going to, would like to) Discussing and drawing conclusion on the use of each Identifying the use of verbs on each expression. <p>3.TASP:</p> <ol style="list-style-type: none"> Speaking , in group of 4 , first each planning some activities on some given future times, then interview each other to find someone who; Writing, then individually make a written report on the result of the previous interview.
<p>4 3.4 Menganalisis fungsi sosial, struktur teks, dan unsur kebahasaan beberapa teks deskriptif lisan dan tulis dengan memberi dan meminta informasi pendek dan sederhana terkait orang, benda dan tempat sesuai dengan konteks penggunaannya.</p> <p>4.4 Menyusun teks deskriptif lisan dan tulis, pendek dan sederhana, terkait orang, benda dan tempat, dengan memperhatikan fungsi sosial, struktur teks, dan unsur kebahasaan, secara benar dan sesuai</p>	<p>1. TAVI :</p> <ol style="list-style-type: none"> Reading a text about a certain famous figure, identifying his personal data, characters and physical descriptions Reading a text about descriptions of some gadgets, analyzing information about the measurements such as size, length, width, weight, as well as materials, origins, color, price and functions; In group reading a chosen text

konteks

about a particular historical monument in the world downloaded from the internet, finding out information about the monument such as the architect, the sovereign, the length of construction period, the materials, the measurement, the functions past and present and the interesting aspects of it.

2. TALO :

- a. In group, collecting as many adjectives as possible to describe characters of person and his physical descriptions as well as nouns about jobs and nationality
- b. In group identifying the ways to ask and describe data about things such as size, length, width, weight, as well as materials, origins, color, price and functions
- c. In group, identifying the ways to ask and describe historical monuments such as the architect, the sovereign, the length of construction period, the materials, the measurement, the functions past and present and the interesting aspects of it.

3. TASP:

- a. Writing, individually writing paragraph about description of the chosen idol with his picture i.e his personal data, characters and physical appearances
 - b. Speaking circle in –circle out taking turns asking and describing each other's idol.
 - c. Writing, individually chose things to be described (animate, animal, plant) and writing each description.
 - d. Speaking , guessing games by coming in front of the class and describing the characteristics of the thing while others guess the
-

- name of the thing. Those who can guess correctly will get the turn to describe his chosen thing
- e. In group of 4, two stand ~ two stray, writing information about their chosen monument
 - f. Speaking, then each two students stand on the picture of the monument stuck on the wall, to present and have QA, the other twos visit other monuments and collect information.
 - g. Writing, finally the 4 students reunite to share information and to make a report on the result of tour.
-

III. CONCLUSION

To sum up, English teachers in Indonesia shouldn't get panicked when the curriculum changes to a Text based one. We should view it this way: we live with language as texts, not as list of vocabulary items and grammar. We are familiar with many texts. We use texts everyday for lots of different purposes starting from doing the hardest tasks in work up to having the slightest fun, from getting up in the morning up to going to bed at night. In short, we interact with texts form the day of birth up to the day of death.

Hence, providing that the curriculum is still a text based one, we English teacher can adjust, master and implement the new version much more quickly as the approaches to view texts do not change. Through the interface of those elements, we can just select motivating text materials (TASE), and design activities to make students gain the meaning of texts (TAVI), and thus we can introduce them with new form of language through activities to work on lexico grammatical aspects of texts (TALO), and to end up with activities that stimulate them to produce new language in oral and written form (TASP), with the graded cognitive skill developing activities (TINKERBEL).

REFERENCES

- Anderson, L. W. and Krathwohl, D. R., et al (Eds..) (2001) *A Taxonomy for Learning, Teaching, and Assessing: A Revision of Bloom's Taxonomy of Educational Objectives*. Allyn & Bacon. Boston, MA (Pearson Education Group).
- Bloom, B.S. et al..(1956.) *Taxonomy of Educational Objectives, The Classification of Educational Goals*. London: Longmans, Green and Co Ltd.
- Brookhart, Susan M. (2010.) *How to Assess Higher-Order Thinking Skills in Your Classroom*. Alexandria, Virginia USA: ASCD.
- Delors, Jaques et al. *Learning: The Treasure Within*. Report to UNESCO of the International Commission on Education for the Twenty First Century. Accessed from <http://www.unesco.unesco.org>. on November 10,2017.
- Department for Continuing Education, University of Oxford. *Exploiting Texts • Text as the Key Unit of*

- Language•TAVI,TALOandTASP.jonhird.com/.../PDF%20EG%20session%204%202016%20 Exploiting% 20Texts.pdf*. Accessed on November 10 , 2017.
- John T., Davies F. (1983) *Text as a vehicle for information: the classroom use of written texts in teaching reading in a foreign language*, Reading in a Foreign Language, 1 (1), pp. 1-19.
- Krulik,Stephen & Jesse A.Rudnick. (1998). *Problem Solving, A Handbook for Elementary Teachers*, Boston: Alyn and Bacon Inc.
- Mickan, P. (2006). Socialisation, social practices and teaching. In P. Mickan, I Petrescu, and J Timoney (Eds.). *Social Practices, Pedagogy and Language Use: Studies in Socialisation* (pp. 7-23). Adelaide: Lythrum Press.
- Nuttall, C., (1996,) *Teaching reading skills in a foreign language*, Oxford: Heinemann English LanguageTeaching.
- Peraturan Menteri Pendidikan dan Kebudayaan NO. 20 Tahun 2016 tentang Standar Kompetensi Kulusan
- Peraturan Menteri Pendidikan dan Kebudayaan NO. 21 Tahun 2016 tentang Standar Isi
- Peraturan Menteri Pendidikan dan Kebudayaan NO. 22 Tahun 2016 tentang Standar Proses
- Peraturan Menteri Pendidikan dan Kebudayaan NO. 203Tahun 2016 tentang Standar Penilaian
- Peraturan Menteri Pendidikan dan Kebudayaan NO. 24 Tajun 2016 tentang Kompetensi Dasar
- Peraturan Pemerintah Republik Indonesia Nomor 32 Tahun 2013 tentang Perubahan atas. Peraturan Pemerintah Nomor 19 Tahun 2005 tentang Standar Nasional Pendidikan.
- Salis.Edward. (2002). *Total Quality Management in Education, 3rd Edition*. London: Kogan Page Ltd
- Saputra,Hatta. (2016). *Pengembangan Mutu Pendidikan Menuju Era Global.Penguatan Mutu Pembelajaran dengan Penerapan HOTS*. Bandung: SMILE's Publishing.
- Verster, Ch. (2005). Interacting with texts – Directedactivities related to texts. South Africa.<http://www.teachingenglish.org.uk/think/read/text.shtml>.
- Wilson, L.O. (2017). Anderson and Krathwohl – Bloom's Taxonomy Revised. Understanding the New Version of Bloom's Taxonomy . *The Second Principle. The work of Leslie Owen Wilson, Ed. D.* <https://thesecondprinciple.com/teaching-essentials/beyond-bloom-cognitive-taxonomy-revised/> Accessed on November 10, 2017.

STUDENTS' DIFFICULTIES IN DESCRIBING SOMETHING

Dewi Sri Kuning

STKIP Muhammadiyah Kotabumi

Jl. Hasan Kepala Ratu No. 1052 Sindangsari Kotabumi

ABSTRACT

Speaking is the most difficult skills from four language skills because individual who learn a language referred as speaker of that language. Speaking not means just saying the word through mouth, but also it conveys the message. There are many materials in speaking found by the students, such as introducing, greeting, giving opinion, describing, leave taking, and many more. There are many problems of students in speaking, especially in describing something. They are because of students' confidence (it includes afraid of making mistake, nervous, and worried when speaking), pronunciation (the students face difficulties in using correct pronunciation), and vocabulary (the students face difficulties in choosing correct adjective). The cause of students difficulties of learning are because of internal, external, and supporting factor. The students solved the difficulties of learning English based on ability and knowledge.

Keywords: *speaking, difficulties, describing something*

I. INTRODUCTION

Language is very important in our lives because by language someone can do communicate with others. Speaking is required by people to interact among them. Speaking skills are often considered the most important part of an EFL course. In foreign language teaching and learning, the ability to speak is the most essential skill since it is the basic for communication. Speaking is one of the productive skills, which is the evidence of a student that how much he or she is competent in a language. Moreover, much of the communication is made through speaking. In short, learning a language remains incomplete if one does not achieve competence in speaking. Speaking can be realized as the most common way to convey the message to others and the ability to communicate effectively is a basic requirement which needs to be taken seriously in English education. In speaking activity, many things that should be paid attention, not only relate to what is being spoken, what the language is used, but also who is our interlocutor. In addition, a good speaker should pay attention what the topic is being spoken by him, what the language that he/she uses in order to be understood easily by his listener, and to whom he/she speaks. Speaking skills are often considered the most important part of an EFL course.

For the beginner of EFL course, many topics which can be learnt firstly, such as introducing, greeting, giving opinion, describing, leave taking, and many more. Some topics above can help them to use simple sentences in understanding English. If they are able to understand well about these, it can help them to say sentences in English further.

One of the topic is about describing. The students can describe person animal or something in English. The rule of describing is by using adjective to tell about noun and pronoun. But, sometimes the students wrong in using adjective because they do not use the suitable adjective and they not master in structure of English. So it can make them difficult in describing something by using oral English.

II. THEORETICAL REVIEW

Speaking is one of four basic skills in learning foreign language besides listening, reading and writing because people who know a language are referred to as speakers of that language (Azadi et.al:2015). Zhang (2009) argued that speaking remains the most difficult skill to master for the majority of English learners, and they are still incompetent in communicating orally in English. Harmer (2007:284) states that speaking is the ability to speak fluently and presupposes not only the knowledge of language feature, but also the ability to process information and the language "on the spot". In foreign language teaching and learning, ability to speak is the most essential skill since it is the basic for communication. Moreover, much of the communication is made through speaking. In short, learning a language remains incomplete if one does not achieve competence in speaking. Speaking can be realized as the most common way to convey the message to others and the ability to communicate effectively is a basic requirement which needs to be taken seriously in English education. According to Kayi (2006) speaking refers to the gap between linguistic expertise and teaching methodology. Linguistic expertise concerns with language structure and language content. Teaching speaking is not like listening, reading, and writing. It needs habit formation because it is a real communication and speaking is a productive skill so it needs practicing as often as possible. Speaking is "the process of building and sharing meaning through the use of verbal and non-verbal symbols, in a variety of contexts" (Chaney, 1998, p. 13). Speaking is an interactive process of constructing meaning that involves producing and receiving and processing information (Brown, 2007; Burns & Joyce, 1997). Its form and meaning are dependent on the context in which it occurs, including the participants themselves, their collective experiences, the physical environment, and the purposes for speaking. (Florez 1999).

The function of speaking are: talk as interaction; talk as transaction; and talk as performance (Burns:1998). First,talk as interview or in another name is conversation. It describes interaction which serves a primarily social function. When people meet they exchange greetings, engage in small talk, tell about their experience and so on because they want to be friendly and having comfortable zone. Second, talk as transaction focus on what is said or done. The message is the central focus here and making oneself understood clearly and accurately, rather than the participants and how they interact socially with each other. And third, talk as performance refers to public which transmit information public announcement and speeches. By some of the functions it shows that speaking is very important skill to be master by learners.

Speaking also has the difficulties in using. Raba'ah (2005:15) pointed out that there are many factors that cause difficulties in speaking English. Some of these factors are related to the learners themselves, the teaching strategies, the curriculum, and the environment.

The cause of students difficulties of learning are because of internal, external, and supporting factor. Internal factor refers to factor that come from learner itself. It's including physiological aspects and learners language competence (ability), and topical knowledge. First, psychology. Brown: 2002, claimed that no successful cognitive or affective activity can be carried out without some degree of self- esteem, self-confidence, knowledge, and belief for that activity. Second, language competence. In speaking performance refers to ability of speaker to master the aspects of language while communicating. These aspects included: fluency, intonation, vocabulary, pronunciation, and grammar. Thrid, topical knowledge. Topical knowledge is the knowledge structures in long-term memory (Bachman & Palmer, 1996 as cited in Tuan & Mai, 2015). They believe that topical knowledge has effects on speaking performance. External factors includes performance condition, and learning environment. First, performance condition include time pressure; planning, the standard of performance, and the amount of support (Nation & Newton, 2009 as cited in Tuan & Mai, 2015). Second, learning environment. English is a language used in communications, so a good language environment can effectively promote learning. But for most of the Indonesian students, English is a foreign language they learn at school, and mostly, students communicate in their everyday life in their native language and too lazy to practice their English outside the class or teaching learning process. Supporting factor as Sadtono (1997) stated divided into linguistic and non-linguistic problem. Linguistic problems include difficulties faced by learner in learning a language related to the aspects of language, such as pronunciation, vocabulary, and grammar. Non linguistic problems such as inhibition, nothing to say, low or uneven participation, and mother tongue use (Ur:2000).

When students are learning a new language they rarely think in that foreign language (L2, and in this case, English); they usually think in the mother tongue. It means that students do not use the patterns of the L2. It produces deviations from the norms of either language affecting all levels of language: accent, pronunciation, syntax, morphology, and vocabulary (McArthur, 1992), and, it affects the L2 learning process as well. When students are learning a foreign language, they tend to transfer to the L2 the structures of their native language. This fact causes some difficulties during the acquisition of the new language. The main differences between the first language and the other are the lexicon, some structure details and some of the sound patterns (García & Molesworth, 1996). These are some of the most common problems students experience during the English language learning process. For example, students use their mother language structure when they are learning how to use adjectives in descriptions, instead of using the ones that the English language has. In descrbing something, adjective is used to describe noun and pronoun. So the positon of adjective is in the first then followed by noun. Example *the poor man lives in the small house*.

Description came from the word describe, the meaning is giving a detailed account in words of speaking or writing (oxford dictionary), or to give a written or spoken report of how something is done or of what someone or something is like (camridge dictionary). So, describing means giving detail information about something. Describing something can be done by speaking and writing English. With this definition, descriptions would give students the opportunity to use adjectives and that through the activities in which

they would have to describe, they would improve their abilities in using the correct order of adjectives and nouns in English. An adjective is a part of speech or word class chiefly used to modify nouns and as a complement to copular verbs such as “be” and “seem” (Richards, Platt, & Weber, 1985). Here some types of adjectives.

Table 1. Eleven Types of Adjectives in English (Khamying, 2007, p. 174 - 179)

No	Types	Functions	Examples
1.	Descriptive Adjective	To attribute or qualify people, animals, things, or places in order to describe its features	The rich man lives in the big house.
2.	Proper Adjective	To modify noun in terms of the nationality, this type is originated from proper noun.	He employs a Chinese book.
3.	Quantitative Adjective	To modify noun for particular details in quantifying	He ate much rice at school yesterday.
4.	Numeral Adjective	To attribute or qualify people, animals, things, or places in order to describe its features	1) Cardinal Numeral adjective Ex. My hand has five fingers. 2) Ordinal Numeral adjective Ex. I am the seventh son of my family. 3) Multiplicative adjective Ex. Some roses are double .
5.	Demonstrative Adjective (this, that, these, those)	To modify noun in terms of the nationality, this type is originated from proper noun.	I invited that man to come in.
6.	Interrogative Adjective	To modify noun for particular details in quantifying	What book is he reading in the room?
7.	Possessive Adjective	To express possession of a noun by someone or something	This is my table.
8.	Distributive Adjective	To modify noun by dividing or separating into different parts	Every soldier is punctually in his place.
9.	Emphasizing Adjective	To modify noun by highlighting or emphasizing the texts	Supansa is my own girl-friend.
10.	Exclamatory Adjective	To modify noun by using interjection words	What a man he is!
11.	Relative Adjective	To modify noun and combine sentence which are related between the first and second sentences	Give me what money you have.

The students need to understand the importance of adjectives when they want to describe about people, objects, or something. So they need to realize that people could talk about one object, but if they added a specific characteristic to that object, the idea about that element immediately changed in people's minds because, as Cramer et al. (1989) mentioned, "adjectives can tell how a noun looks, feels, tastes, sounds, or smells" (p. 150). The features found in this category were analyzed at sentence level—the chunks that characterized students' attempts to produce different descriptions (Jara:2012). There are many objects in describing something such as people animals, place and things. All adjectives are descriptive words, but not all descriptive words are adjectives. Here 4 useful ways of describing people in English (Geikhman:2018).

1. Describing someone's appearance

- ✚ To describe someone's height, you can say they are tall or short. Tall people are higher than short people. Someone who is thin and tall can be called lanky. To say someone is short and also small, you can say they are petite. If you're talking about a child, they might be pint-sized.
- ✚ Someone who weighs more than average can be curvy, well-built, full-bodied or heavy. (Curvy is usually only used to describe women.) You might also say someone has some meat on their bones. This is a casual way of saying they are overweight, and it might seem rude to someone sensitive. The opposite of overweight can be thin, slim or skinny.
- ✚ Light, yellowish hair can be described as blonde. But you can also call a person who has that kind of hair a blonde. (This means blonde can be used as a noun or an adjective.) A person with dark hair can be called a brunette. Someone with red hair can be called a redhead.
- ✚ Besides what color someone's hair is, you also can say they are short-haired or long-haired. You can say they have curly, straight or wavy hair. Sometimes hair can also be frizzy, which is when it looks puffy with small, tight curls. If someone has no hair at all on their head, they are bald.
- ✚ Men sometimes have hair on their faces. Hair that covers the chin and cheeks is called a beard. When there's hair only above the lips it's a moustache. A beard that's only on the chin can be called a goatee. None of these are adjectives. They are all nouns. To describe someone with a beard, you would say, "He has a beard."
- ✚ How does a person look overall? If you think a woman is attractive, you can say she is beautiful, pretty or maybe even gorgeous (very beautiful). You can call an attractive man handsome. Both men and women can be good-looking. If you're speaking very casually, good-looking men or women can be hot. To say someone is not very good-looking, you can say they are not much to look at. This is not a nice way to describe someone, but it's better than ugly.
- ✚ If someone dresses well, they are smartly dressed or they look smart. You can also just say they are well-dressed. If someone dresses fashionably, they are stylish or trendy. If someone has bad taste in clothes, you can say they're unfashionable. A less nice way to say this is frumpy.

2. Describing someone's mannerisms

- ✚ Many people have mannerisms that appear when they're feeling negative (bad) emotions. If someone feels nervous or impatient, for example, they might tap their fingers, crack their knuckles, bite their fingernails or chew the tips of their pencils.
- ✚ Sometimes people don't even notice that they twirl their hair around their finger. Other times mannerisms are deliberate (on purpose). For example, someone might roll their eyes to show that they're being sarcastic (not serious).
- ✚ When a person thinks hard about something, they sometimes tilt their head to the side or even stick out their tongue.
- ✚ You can sometimes tell someone is annoyed if they rub the back of their neck, sigh a lot or clench their hands.

3. Describing someone's character

- ✚ We all know people who are nice and kind. They are a pleasure to be with and always seem to be smiling. These people are usually also friendly and generous. People who are generous like to help others by giving them things. Someone who is the opposite of nice is mean. Mean people can be unpleasant, nasty or vicious. Hopefully you don't know anyone like this!
- ✚ Some people always show respect to others, which makes them polite and well-mannered. Someone who doesn't care about other's feelings or rules is rude and impolite. If they use bad language, you can say they are vulgar or obscene.
- ✚ Someone smart is intelligent or clever. If they are smart because of age or experience, they can be called wise. Someone who is not very intelligent could be dumb or slow, but a slightly nicer way to say that is that they're not too bright.
- ✚ How does the person you're describing deal with difficult situations? Some people get angry easily. They are hot-headed. Others are calm and sensible and look at everything in a relaxed way. Others go right from being calm to being mad. They are moody.
- ✚ To describe a person who does not like to go out or be with people much, you can use the word introvert. If that person doesn't talk a lot and doesn't seem comfortable around others, they might be shy. People who love company and parties are extroverts. They are often easy-going, meaning not much bothers them.
- ✚ Someone who tries hard to do big things is ambitious. They might also be resourceful. Resourceful people use everything they can to help them reach a goal. Someone who is happy with what they have can be called content or fulfilled. None of these are bad things to be.
- ✚ If a person is good at making people laugh, they are funny. If they're funny in a clever (smart) way, they're witty. Some people don't like to laugh a lot, and are very serious instead. Sometimes serious people can seem boring.
- ✚ Arrogant, conceited people are not fun to be around because they act like they are better than you. They can be show-offs, meaning they try to make you see how

great they are. Modest people don't show off how great they are, even if they're awesome!

4. Describing someone's feelings

- ✚ You can use these words to talk about how someone is feeling, how they were feeling before or how they might feel in the future.
- ✚ There are so many ways to say that someone is happy! They can be elated, exuberant, cheerful, delighted or even ecstatic (very, very happy). Someone sad might be described as melancholy, miserable (very sad) or out of sorts.
- ✚ When something makes a person mad, they become angry or fed up. Someone very angry is furious or livid. Stay away from those people!
- ✚ We all feel like we have too much to deal with sometimes. This can make us stressed and anxious. New or scary things can make us nervous. Once that stress is gone, you can feel tranquil or serene, which are other ways of saying relaxed.
- ✚ Did the person you're describing get enough sleep last night? If not, they might look tired or worn out. If they look extremely tired, they might be exhausted. Sleeping well makes a person look well-rested.
- ✚ If someone looks like they're not interested in what's going on around them, they might seem bored. If they're very interested, you might say they're enthusiastic.

Because in describing something uses the adjectives, here some list of descriptive words (adjectives):

Adorable	Conventional	Intrepid	Miserable
Adventurous	Delirious	Joyful	Nocturnal
Acclaimed	Demanding	Jubilant	Organic
Accomplished	Flustered	Keen	Ornate
Acrobatic	Focused	Kooky	Ordinary
Brave	Foolhardy	Lanky	Powerless
Bright	Gregarious	Lazy	Practical
Brilliant	Grim	Limp	Precious
Composed	Handsome	Luxurious	Puzzled
Concerned	Handy	Mediocre	Questionable
Concrete	Intelligent	Mellow	Quirky

Adjectives can be used to describe lots of things, from physical size, age, shape, colour, material, to more abstract things like opinion, origin and purpose. We can use adjectives together to give a detailed description of something. Adjectives that express opinions usually come before all others, but it can sometimes depend on what exactly you want to emphasise. When we group adjectives together there is a general (sometimes flexible) rule for the position of each type of adjective, these are:

	1st	2nd	3rd	4th	5th	6th	7th	8th
Position	Opinion	Size	Age	Shape	Colour	Material	Origin	Purpose
	Nice	Small	Old	Square	Black	Plastic	British	Racing
	Ugly	Big	New	Circular	Blue	Cotton	China	Running

You might swap adjectives that express an opinion and an adjective based on fact depending on what you wish to emphasise.

III. CONCLUSIONS

Speaking is the something which is important in studying language. Speaking is an activity of delivering messages, it occurs between speaker and listener orally. In this case, the speaker and listener should be able to understand each other. The speaker can produce the sounds that involved the messages and the listener can receive, process, and response the messages. Speaking is not easy for the students or the beginner of EFL so they have some problems which cause of students difficulties of learning. They competence of language performance, pronunciation, vocabulary, nonhibition, mother tongue, and grammar. In grammar the students should understand the way or the structure to describe something. The structure is by the position of adjective is in the first then followed by noun. If the students have many practices to describe something by using correct in grammar by speaking it can solve the difficulties of it. Also the teacher can help the students to use adjective in correct way in describing something. So beside practises also knowledge of using grammar in correct way is important for students.

REFERENCES

- Azadi Somayeh, S., et al. 2015. The role of classroom interaction on improvement of speaking among Iranian EFL learners. *International Journal of Language Learning and Applied Linguistics World (IJLLALW)* Volume 8 (1), January 126---135 www.ijllalw.org.
- Bachman, L. F., & Palmer, A. S. 1996. *Language testing in practice*. Oxford: Oxford University Press.
- Brown, H. D. 2002. *Strategies for success: A practical guide to learning English*. White Plains (N.Y.): Longman.
- Brown, H. D. 2007. *Principles of language learning and teaching*. White Plains, NY: Pearson Longman.
- Burns, A. & Joyce, H. 1997. *Focus on speaking*. Sydney: National Center for English Language Teaching
- Burns, Anne. 1998. Teaching Speaking. *Annual Review of Applied Linguistic* 18, 102-123.
- Chaney, A.L., and T.L. Burk. 1998. *Teaching Oral Communication in Grades K-8*. Boston: Allyn&Bacon.
- Cramer, R., Beers, J., Triplett, W., Najimy, N., Ward, L., Welles, C., & McCarthy, T. 1989. *Language*. Glenview: Scott Foresman Company.

- Dictionary your. List of Descriptive Words: Adjectives, Adverbs and Gerunds. Retrieved from: <http://grammar.yourdictionary.com/word-lists/list-of-descriptive-words.html>. (20 October 2018)
- Florez MaryAnn Cunningham. 1999. Improving Adult English Language Learners' Speaking Skills, National Center for ESL Literacy Education June
- García, M. A., & Molesworth, D. J. 1996. *Unravelling Spanglish. A practical guide to language interference*. Tunja, Colombia: Universidad Pedagógica y Tecnológica de Colombia.
- Geikhman Yuliya. English Language and Culture Blog. Retrieved from: <https://www.fluentu.com/blog/english/describing-people-in-english/>. (20 October 2018)
- Harmer, J. 2007. *The Practice of English Language Teaching*. Harlow: Longman.
- Jara. Omar Yesid Lizarazo. 2012. Using a Blog to Guide Beginner Students to Use Adjectives Appropriately When Writing Descriptions in English. PROFILE Vol. 14, No. 1, April 2012.
- Kayi, Hayriye. 2006. Teaching Speaking: Activities to Promote Speaking in a Second Language. University of Nevada. The Internet TESL Journal, Vol. XII, No. 11, November 2006 (<http://iteslj.org/> being accessed on October 20th, 2018)
- Khamying, S. 2007. *Advanced English Grammar for High Learner*. Bangkok: V.J. Printing
- McArthur, T. 1992. *The Oxford companion to the English language*. Oxford: University University Press.
- Nation, I. S. P., & Newton, J. 2009. *Teaching ESL/EFL Listening and Speaking*. ESL & Applied Linguistics Professional Series. Routledge Taylor & Francis Group.
- Network Leo. Learn English Grammar. Retrieved from: <https://www.learnenglish.de/grammar/adjectiveorder.html>. (20 October 2018)
- Raba'ah, G. 2005. *Communication Problems Facing Arab Learners of English* Journal of Language and Learning, 3(1), ISSN 1740-4983.
- Richards, J. C., Platt, J., & Weber, H. 1985. *Longman dictionary of language teaching of applied linguistics*. London: Longman.
- Sadtono, E. (1997). *Perspective of English teaching in indonesia*. Malang: FPBS IKIP Malang.
- Tuan, N., H & Mai T., N. (2015). Factors affecting students' speaking Perform ance at le thanh hien high school. *Asian Journal of Educational Research*, 3(2). Retrieved from: www.multidiciplinaryjournals.com
- Ur, P. 2000. *A Course in Languge Teaching: Practice and Theory: Trainer's Handbook*: Cambridge University Press, UK
- Zhang, S. 2009. The role of input, interaction, and output in the developmentof oral fluency. *English Language Teaching*,2(4),91–100.

ERROR ANALYSIS IN SUBJECT-VERB AGREEMENT OF ENGLISH DEPARTMENT GRADUATE STUDENT'S THESIS AS EFL LEARNERS BASED ON SURFACE STRATEGY TAXONOMY

Khairun Nisa
University of Lampung
khairun.nisa31092@gmail.com

ABSTRACT

Error analysis became a common method of getting information about learners' language during the early 1970s and error analysis is still considered a useful tool to gather information about learners' language. According to Ellis (1997:35), "Errors reflect gaps in a learner's knowledge, they occur because the learner does not know what is correct". As the authors illustrate, EA can become a useful tool to improve language teaching and, consequently, student learning. This article analyzes errors on subject-verb agreement among English Department graduate students as EFL learners in Lampung University. One sample of English department graduate student's thesis was used to gain the data. Three types of SVA (Subject-verb Agreement); SVA of person, SVA of number, and agreement with coordinate subject were analyzed in this descriptive qualitative study. After gaining the data, the researcher used a theory termed as Error Analysis, which is developed from S.P. Corder's theoretical framework and classified the SVA errors based on surface strategy taxonomy stated by Dulay et al. The thesis was analyzed to identify the students' problems in grammatically correct SVA by classifying those errors into surface strategy taxonomy. The result revealed that English department graduate student as EFL learners still made some errors in SVA of number and SVA of person, which is included in omission (62.5%), addition (4.17%), misformation (33.33%), and misordering (0%) based on surface strategy taxonomy.

Keywords: *error analysis, EFL learners, subject-verb agreement, surface strategy taxonomy*

I. INTRODUCTION

Error analysis became a common method of getting information about learners' language during the early 1970s and it became as an alternative method to contrastive analysis which was based on behaviorist theories and therefore claimed that the difficulties in mastering certain structures in a second language (L2) were only based on the differences between the learners' mother language (L1) and the second language (L2).

Error analysis has become less used mainly because it has some limitations. First, it only focuses on learners' errors and not on what learners can do right. Another disadvantage of EA is the fact that it overemphasizes production data. Errors analysis fails to account for avoidance strategy.

Despite these drawbacks, error analysis is still considered a useful tool to gather information about learners' language. Error analysis enables teachers to find out the sources of errors and take pedagogical precautions towards them. EA constitutes a link

between language learning and teaching that can be exploited in initial as well as remedial teaching.

According to Ellis (1997:35), “Errors reflect gaps in a learner’s knowledge, they occur because the learner does not know what is correct”. As the authors illustrate, EA can become a useful tool to improve language teaching and, consequently, student learning.

Errors in language learning have always been the center of attention and knowledge of grammar has become one of the most actively discussed questions in language and literacy pedagogy. According to Richards and Sampson (1974), social situations and the learner’s value and attitudes may influence learner-errors. Errors committed by the learners revealed the true state of foreign language learners’ proficiency of the new language they are learning at a particular point of time. Apart from that they also revealed what the foreign language learners do not know what they have internalized of the new language system.

When grammar is concerned, the knowledge occurs in different stages in a person’s language development. In order to perform certain language task, some relevant grammatical structures need to be mastered by a beginner. He only needs to comprehend some rules enough to use them like the basic rules of SVA and to know how to apply the rules in forming sentences. As for upper level students, they probably need to be able to understand the rule of SVA in depth and discuss the grammatical problems with their teachers.

Researcher like Bhatia (1974) as cited by Munir Shuib (1991) indicates that agreement presents a problem to ESL learners. This is supported by Surina and Kamarulzaman (2009) when they claim that majority of the students in Malaysia still have problems with their subject-verb agreement in their writing. In addition, Malaysian ESL learners face problems in subject-verb agreement because in their L1 (generally a person’s mother tongue or the language acquired first) which is Bahasa Malaysia, there is no such rule regarding subject-verb agreement. In Bahasa Malaysia all subjects either singular or plural require the same form of verb.

Besides, Chen and Reynolds (2009) found that students in Taiwan committed common errors as they write business writing; application letter, inquiry letter, response letter, sales letter and offer letter. The students mostly did errors mistakes in spelling, punctuation, custom, capitalization and subject-verb agreement.

Realizing the issues mentioned above, the writer thinks about EFL learners, how the EFL learners use SVA in writing since Malay and Indonesian have almost the same mother tongue. Both of Malay and Indonesian do not have SVA rule in writing. This makes the writer try to find the data on the problems of subject-verb agreement faced by EFL learners of English department graduate students’ thesis. By looking at the result, this will determine actions to be taken in the teaching and learning EFL grammar.

The writer also wants to classify the SVA errors into surface strategy taxonomy. They are omission, addition, misformation, and misordering. This can help us to get information

about the difficulties students face when learning a foreign language and why they make the errors. With this information, it can be as reminder for the EFL learners which is doing the thesis to give attention to this case since SVA is as the basic grammar rule in writing L2 that they cannot find it in L1. In addition, for the graduate English department students, they have to always learn even they are already as a teacher.

After doing this study, the researcher expect that the result can answer these questions:

1. Is there any SVA error made by the English department graduate student as the EFL learner?
2. What are the most frequent SVA errors in the students' writing thesis of English department graduate students?
3. What are the percentages of SVA errors in the students' writing thesis of English department graduate students based on surface strategy taxonomy?

II. METHODS

This research used descriptive qualitative research. The researcher took an English Department student's undergraduate thesis as the sample. After gaining the data, the researcher used a theory termed as Error Analysis, which is developed from S.P. Corder's theoretical framework. Corder (1974) states that Error Analysis assumes the learners make major elements in the feedback system of language teaching and learning process. After finding some errors inside the thesis, then the writer will categorize into three types of SVA. They are the subject-verb agreement of person, the subject-verb agreement of number, and the agreement with coordinated subject.

These three categories of subject-verb agreement are used as the basis for error analysis. Moreover, these three categories include the general rule and also the sub-rules of subject- verb agreement. The frequency of errors in each category was then calculated and compared in terms of percentages.

Then, to answer the last research question, the researcher classified the SVA errors based on surface strategy taxonomy stated by Dulay et al (1982). They are omission, addition, misformation, and misordering. After classifying the data, the researcher calculated the result to know the percentage of each type of SVA errors based on surface strategy taxonomy.

III. RESULTS AND DISCUSSION

After analyzing the English department graduate student, the researcher found that the subject of this research had made errors in his thesis which were identified to 3 subject-verb agreement categories. The result of the use of subject-verb agreement in the thesis sample is displayed in the Table 1 below.

Table 1. Total Number and Percentage of SVA Errors

No.	Kinds of SVA errors	The errors	The total errors	The percentage of errors
1.	Subject Verb Agreement of Person	9	24	37.5%
2.	Subject Verb Agreement of Number	13	24	54.17%
3.	Subject Verb Agreement with Coordinated Subject	2	24	8.33%

Table 1 indicates the findings of errors from the sample of thesis. The findings show that the 37.5% of errors goes to SVA of person. Here are some errors that the researcher found in the sample:

- From **those** who **ignores** the lesson
- The **researcher have** procedure in collecting the data
- In brain storming, **teacher ask** some questions related...
- So the **student know** what kind of question...
- In this activity, **teacher narrate** a story to the class.
(See appendix for the complete one)

The researcher found that the writer was still confused with the use of matching based on SVA to associate the singular noun or subject with the singular verb. The correct sentences from the errors should be:

- From **those** who **ignore** the lesson
- The **researcher has** procedure in collecting the data
- In brain storming, **teacher asks** some questions related...
- So the **student knows** what kind of question...
- In this activity, **teacher narrates** a story to the class.

Table 1 also indicates that the thesis writer has problems with subject-verb agreement of number. There are 54.17% errors were committed in the thesis. This category is the most committed errors found in the sample. In subject verb agreement of number, verb may change forms depending on whether its subject is singular or plural. For example, a singular, first-person subject requires a different form of the verb, to be, than does a plural, first person subject. There are the examples of the errors found by the researcher:

- The **content were** pronunciation, fluency, grammar, ...
- **A high motivated one** also **have** a problem...
- **Each student** in a group **choose** a card.
- **One of the group members** **tell** to the class about the picture.
- **Very limited vocabulary** **make** comprehension quite difficult.
(See appendix for the complete one)

From those sentences, it shows that the writer who is graduate student from English department is still confused to make a sentence especially SVA of number in the correct sentence. Those sentences should be:

- The **contents were** pronunciation, fluency, grammar, ...
- **A high motivated one** also **has** a problem...
- **Each student** in a group **chooses** a card.
- **One of the group members** **tells** to the class about the picture.
- **Very limited vocabulary** **makes** comprehension quite difficult.

The last, subject-verb agreement with coordinated subject was also made by the writer. Table 1 shows that this is the least error committed by the writer. It is only 8.33% counted by percentage. The errors of SVA with coordinated subject can be seen as follows:

- **Problem** usually faced by the students **are**...
- **Using story telling** in teaching speaking **help** the students be creative.

Based on the SVA with coordinated subject, those sentences have not been correct. The correct sentences should be:

- **Problem** usually faced by the students **is**...
- **Using story telling** in teaching speaking **helps** the students be creative.

Those are the examples of SVA errors that the researcher has found in the sample of the thesis of English department graduate student. This result also supports the previous research of Bhatia (1974) as cited by Munir Shuib (1991) that indicated SVA presents a problem to ESL learners since ESL and EFL learners have different rules of mother tongue from the L2.

After getting the SVA errors, the researcher classified the data into some kinds of error based on surface strategy taxonomy, which are described in the table below.

Table 2. Errors Classification based on Surface Strategy Taxonomy

No.	Types of Errors	Errors
1.	Omission	<ul style="list-style-type: none"> - Communicating with others mean understanding... - Teacher ask some questions... - Teacher give chances... - Curiosity encourage the students... - One of the group members tell to - Teacher stop narrating... - Each student in a group choose a card. - Each student write 4-5 questions... - Teacher narrate a story... - Using story telling in teaching speaking help

		the students... - Student know what kind... - Very limited vocabulary make comprehension... - This fragmentary fluency make conversation... - for English teacher who want to try to.... - The content were pronunciation, fluency,..
2.	Addition	- and from those who ignores the lesson
3.	Misformation	- while the active skills they get is only writing.... - A high motivated once also have a problem... - Problem that usually faced by the students are... - Sand or something strange are inserted... - Each group have a picture... - Teacher have some sequential... - One student have the information... - the researcher have procedure in collecting...
4.	Misordering	-

From the classification above, the researcher found the percentage of the SVA errors were classified based on surface strategy taxonomy as follows:

Table 3. The Percentage of SVA Errors Based on Surface Strategy Taxonomy

No.	Types of Errors	Total Errors	Percentage
1.	Omission	15	62.5%
2.	Addition	1	4.17%
3.	Misformation	8	33.33%
4.	Misordering	-	0%
Total Errors		24	

The result showed that the highest percentage of the errors was omission. This was because of the different rules of language between the writer's mother tongue and the target language. Since the writer's mother language is Indonesian, there are no specific rules in constructing sentence with different subject whether it is singular or plural, for examples:

Singular:

- Student knows that thing.
- *Siswa mengetahui hal itu.*

Plural:

- They know how important learning English is.
- *Mereka mengetahui pentingnya belajar bahasa Inggris.*

In this case, the writer seemed like omitting all suffixes that should be appear in the verb. The researcher found that the thesis writer over generalized the target language's rules, which is the difference between singular and plural subject in making some sentences so that mostly errors popped up in omission. On the other hand, there was no misordering error found by the researcher. This is because there is no different sentence structure between Indonesian and English, which is subject verb/predicate and object/complement as follows:

- Teacher asks some questions. (SVO)
- *Guru bertanya beberapa pertanyaan.* (SVO)

This similarity makes the writer became easy to construct a sentence appropriately based on the sentence structure in English. That was why this kind of error could not be found in the sample.

IV. CONCLUSION AND SUGGESTION

The findings of this study revealed that though the subject of this research was the thesis of English department graduate student that still can be found SVA errors, which it is as the basic rules of structure. It seems like the sample was still confused so he still made mistakes in all three categories of subject-verb agreements namely: the subject-verb agreement of person, the subject-verb agreement of number, and the subject-verb agreement of coordinated subject. In SVA errors, which were found by the researcher, the errors were mostly included in omission and no misordering error was found by the researcher. It is, thus, important for remedial actions be taken to curb this problem. Students should be more careful in writing especially concerning on the rules of the target language. They should be aware of the differences between their mother tongue and English grammar so that they will not transfer literally their L1 grammar to the L2. They also should consider also the rules, which exists in the L2.

REFERENCES

- Bathia, T. K. (1974). *The Handbook of Bilingualism*. London: Blackwell.
- Corder, S.P. (1967) Error Analysis in Allen, J. L. P. and Corder, S.P. (Eds) *Techniques in Applied Linguistics*. Oxford: Oxford University Press.
- Dulay, H., M.K. Burt & S. Krashen. 1982. *Language Two*. New York: Oxford University Press.
- Ellis. (1997). *Second Language Acquisition Research and Language Teaching*. Oxford: OUP.
- Munir, Shuib. (1991). *An Analysis of Malaysian Learners' English Agreement Errors*. University of Essex. M. A. Dissertation.

- Reynolds, J Arthur, Chen, Chin-Chih and Janette E. (2009). *A Research Synthesis and Evidence on Prevention*. Herbers University of Minnesota
- Richards, J and Sampson, G. (1974). The Study of Learners English, in Allen, J. L. P. and Corder, S. P. (Eds) *Techniques in Applied Linguistics*. Oxford: Oxford University.
- Stapa, S. Hamin and Izahar, M. Mustafa. (2013). Analysis of Errors in Subject-Verb Agreement among Malaysian ESL Learners. Malaysia: 3L Journal.
- Surina, Nayan and Kamaruzaman, Jusof. (2009). A Study of Subject-Verb Agreement: From Novis Writers to Expert Writers. *International Education Studies* Vol.2, No. 3.

**THE INFLUENCE OF USING REALIA TO IMPROVE STUDENTS'
VOCABULARY AT SMP N 2 NATAR
IN THE ACADEMIC YEAR OF 2017/2018**

Eva Faliyanti¹, Alanda Liantara²

English Education Study Program, Faculty of Teacher Training and Education
Muhammadiyah University of Metro^{1,2}

ABSTRACT

This undergraduate thesis analyzes about the use of realia can be influential in the development of vocabulary for students at SMP N 2 Natar. Realia media is one of cooperative media which is suitable to teach Students' vocabulary. Realia means using real items found in the world around us to help the teacher provide improve student mood be enjoyable and memorable in the learning process. In conducting this research, the researcher used the true experimental method. The researcher took two classes with name experimental class and control class. Pre-test and Post-test were given in both classes. The experimental class was treated by Realia media before the researcher conducted the Post-test, and the control class was treated by regular method before the researcher conducted Post-test. In obtaining the data of this research, the researcher conducted Post-test in experimental class and also in control class to find out the students' vocabulary comprehension and after the researcher analyzed the obtained by using t_{test} , the result of Pre-test in experimental class show that 44 as the minimum score, and 68 as the maximum score and the result of Pre-test in control class show that 44 as the minimum score, and 78 as the maximum score. After the researcher treated by used Realia as a media in experimental class the result Post-test in experimental class score increasing up to 52 as the minimum score, and their score is also increasing up to 84 for the maximum score and the result Post-test in control class be found the difference score show that 48 as the minimum score and 76 as the maximum score. Furthermore, the hypothesis test of this research is accepted, the result of analysis as presented in table 4.11 indicated that the value of t obtained (9,966) was higher than that of t table (2.039) at the significance level 0.05 and the significance (0.000) was lower than 0.05 (Appendix 6). It's clear that the hypothesis test of this research is accepted, it means that influence of using Realia to improve students' vocabulary at SMP N 2 Natar at the second grade is effective.

Keywords: *influence, realia, vocabulary*

I. INTRODUCTION

Vocabulary is the essence of the language as the most important part of learning a language, mastering vocabulary for students is the key to be successful in comprehending English. Without vocabularies, speakers cannot convey the meaning and communicate with each other in a particular language. Therefore, mastering vocabulary is the key to be successful in comprehending English as a foreign language. According James Milton (2009: 7) Mastery of vocabulary is an essential component of all uses of language; it helps student too to communicate effectively or expressing students' ideas in English.

Based on K13 curriculum that use for Second Grade Students' of SMP N 2 Natar, one of the including competencies for vocabulary that should be learnt by the student's is to comprehend about the short functional text and to identification of vocabularies such as adjective, verb, pronoun and noun, appropriate grammar, and give the information based on the situation.

However when the researcher has an interview the teacher in SMP N 2 Natar about students' vocabulary at Second grade of SMP N 2 Natar, there are a lot of problems in learning process such as; the condition of the students who are lack of vocabulary that will make them unable to say word during teaching and learning English class, the most of students' are not confident to said vocabulary related to the object, the students' often speak their local language.

One of the important media to teaching vocabulary is using Realia. Harmer (2001: 140) state that Realia or real items are used for teaching and learning in the classroom. Objects that are intrinsically interesting provide a good starting point for a variety of language work.

Realia means using real items found in the world around us to help the teacher provide improve student mood be enjoyable and memorable in the learning process, actually Realia as a media in teaching learning process to preserve related between teacher and students.

According to Harmer (2001: 140) realia or real items are used for teaching and learning in the classroom. Objects that are intrinsically interesting provide a good starting point for a variety of language work and communication activities, Realia also makes the learning process more enjoyable.

It can be concluded that using realia for the students can use all of their senses, eyes, ear, and hand so their understanding does not only come just from explanation but also from what they see, heard, and crucially they have a chance to touch and interact with.

II. METHODS

The researcher used true experimental design, therefore in this research the researcher used random sampling to get experimental class and control class. In this research the

researcher used random sampling to get experimental class and control class. Therefore the researcher wants to pre-test to know the students' pre initial ability, then the researcher do the treatment before doing post-test.

Research Instrument

Kinds of Research Instrument

The researcher used multiple choice tests to measure the result of students' vocabulary mastery before and after the treatment. The researcher administers try out to know whether the question test valid and reliable or not, to used in Pre-test. After all the test is reliable the researcher doing pre-test before treatment, after the treatment done the researcher doing post-test.

Validity and Reliability

Validity

The validity is to measure the extent to which the instrument measures what in the purports to measure.

The formula of validity as follow:

$$r_{xy} = \frac{N \cdot \sum XY - (\sum X)(\sum Y)}{\sqrt{\{N \sum X^2 - (\sum X)^2\} \{N \sum Y^2 - (\sum Y)^2\}}}$$

Where

- r_{xy} = Coefficient correlation person product moment
- N = The number of students'
- \sum = Sum
- X = The score items of the test
- Y = The total score of the test
- x^2 = Deviation X
- y^2 = Deviation Y

Reliability

Reliability refers to extension to which the test is consistent in it is score and give an indication how accurate the test score is.

Spearman Brown formulas' as follow:

$$r_{xy} = \frac{\sum xy}{\sqrt{(\sum x^2)(\sum y^2)}}$$

Note

- r_{xy} = Correlation between x and y
- $\sum xy$ = Total x time y
- x^2 = Deviasi x
- y^2 = Deviasi y

Data Analysis Technique

The technique of data was conducted to analyze the validity and then pre-test and post-test of the questions.

Normality Test

The object test for normality to determine the distribution of the data follows a normal distribution or not.

$$x_{count}^2 = \sum_{i=1}^k \frac{(O_i - E_i)^2}{E_i}$$

Notes:

x^2 = Chi-square

O_i = frequency observed

E_i = frequency expectation

k = Interval class

The criterion, if $X_{count}^2 \leq X_{table}^2$ with $dk = k - 3$, so, the data is normal.

Homogeneity Test

Homogeneity test is to measure which can be used to determine data variation.

$$F = \frac{\text{biggest variants}}{\text{smallest variants}}$$

Accepted H_0 if $F_{ratio} \geq F_{\frac{1}{2}\alpha}(V_1 - V_2)$, with $V_1 = n_1 - 1$ and $V_2 = n_2 - 1$

(Setiadi, 2006: 249)

Hypothesis Test

Hypothesis is an assumption about a population parameter. Repeated Measures T-test was conducted and the used formula of the test is t-test which frames at this below formula:

$$t_{\text{-test}} = \frac{\bar{X}_1 - \bar{X}_2}{\sqrt{\frac{s_1^2}{N_1} + \frac{s_2^2}{N_2}}}$$

Notes:

\bar{X}_1 = the means of the experiment class

\bar{X}_2 = the means of the control class

S = the standard deviation

N_1 = the number of students' in the experimental class

N_2 = the number of students' in the control class

Based on explanation above, the researcher concludes that hypothesis is an assumption about population parameter. This assumption may be true or not, the sample data are not consistent with the statistical hypothesis, so the hypothesis is rejected. Because the test is used to know whether the hypothesis that is proposed can be accepted or reject. The formula is used in this test is t-test.

III. RESULTS AND DISCUSSION

The first is the description of the experiment which describes the pre-test, the experiment stages, and the post-test.

Pre Test

The researcher gave a vocabulary test that consisted of 25 items. When the time was over, the students submitted their answer sheets to their teacher.

Table 4.1

Data Description of Pre-test Result in the Experimental and Control Groups

Data Description	Score	
	Experimental group	Control group
Number of Cases (N)	32	33
Mean (M)	56.50	57.15
Standard Deviation (SD)	6.41	8.38
Range	24	32
Maximum Score	68	76
Minimum Score	44	44

The Treatment Stages in Experimental Group

The researcher presented realia to measure the students' vocabulary mastery.

The Treatment Stages in Control Group

In teaching vocabulary without realia, the teacher applied practice techniques employed generally consist of guided repetition and substitution activities.

The post test

The researcher gave the test toward both groups

Table 4.5

Data description of Post-test in the Experimental and Control Groups

Data Description	Scores	
	Experimental group	Control group
Number of Cases (N)	32	33
Mean (M)	69.38	59.64
Standard Deviation (SD)	9.23	7.29

Range	32	28
Maximum Score	84	76
Minimum Score	52	48

IV. CONCLUSION AND SUGGESTIONS

The use of realia in teaching and improving students' vocabulary is more effective than other media. From the two classes, the experimental and control group. The measurement shows that increasing line of the vocabulary mastery of the experimental group was higher than the control group. The t-test measurement obtained is 9,966, for α : 5% and the probability is 0.00. The t-test table is 2.039 out of degree of freedom (df) 31. This means that the t-test was higher than the t-table. It is found that the achievement of experimental group in vocabulary test was better than the control group.

Based on the conclusion, it was suggested:

- a. For Teachers
English teacher should improve his knowledge of the use of realia in teaching English. English teacher must be able to use comics strip in teaching –learning process in the classroom, so that the students will be interested in learning English.
- b. For students
Students should do much practice in leaning English vocabulary. The use of realia in improving vocabulary is not only for classroom teaching-learning process, but it can be applied in a daily activity.
- c. For Institution/school
This research result can be used as theoretical references for the sake of improving English teaching quality and English learning process.

REFERENCES

- Ahmad, Tanzeh. (2004). *Metode Penelitian Praktis*. Tulungagung Pusat Penelitian dan Pengabdian Kepada Masyarakat. (P3M)
- Arikunto, S. (2010). *Prosedur Penelitian Suatu Pendekatan Praktik*. Jakarta: PT. Rineka Cipta
- . (2006). *Prosedur penelitian suatu pendekatan praktik*. Jakarta: edisiRevisi VI, PT. Rineka Cipta.
- . (2002). *Prosedur Penelitian Suatu Pendekatan Praktek*. Jakarta: PT Rineka Cipta.
- Brown, D. (2004). *Language Assessment Principles and Classroom Practices*. New York, NY: Pearson Education.
- Fadillah, Silvimaulidha (2015). *The Influence of Using Realia on The Students' Vocabulary Mastery at Junior High School*. Syarif Hidayatullah State Islamic University of Jakarta
- Hanson, Susan and Padua, Jennifer F.M. (2011). *Teaching Vocabulary Explicitly*. Hawaii: Pacific Resource for Education and Learning.
- Harmer, Jeremy. (2001). *The Practice of English Language Teaching*. England: Pearson Education Limited.
- Ibrahim, R. dan Nana Syaodih. (2003). *Perencanaan Pengajaran*. Jakarta: Rineka Cipta.
- Kurniati, Emi. (2016). *The Implementation Of Realia As Media In Teaching Vocabulary Of Fourth Grade Students At SDN 55 Gedong Tataan Pesawaran*. University Of Lampung.
- Lubis, Arfan Ikhsan. dkk. 2017. *Teori Akuntansi*. Medan: Madenatera
- Manandhar, S. (2009). *Ways of Teaching Vocabularies to Beginners*. Available in <http://symmaruna.wordpress.com/2009/08/18/ways-of-teachingvocabularies-to-beginners/>. Retrieved on 20 January 2016.
- Mulyani, Endang. (2015). *The Use of Realia to Improve Students' Speaking Skill*. Institute for Islamic Studies (IAIN) Salatiga.
- Milton, James. (2009) *Measuring Second Language Acquisition*. Bristol: Short Run Press Ltd.
- Noor, Mustain. (2009). *Pengaruh Bermain Peran terhadap Minat Belajar Anak pada Kelompok Bermain Zahrotuth Tholibin Desa Undaan Lor*. Graduating paper. Kudus: Universitas Muria Kudus.
- Pujita. (2006). *Media Pembelajaran*. (online). ([http:// wordpress.com](http://wordpress.com), terakhir pada 10 September 2014. 20.00 WIB)
- Read, John. (2000). *Assessing Vocabulary*. New York: Cambridge University Press.
- Sadiman, A. S., Raharjo, R., and Haryono, A. (2009). *Media Pendidikan*. Jakarta: Pustekom Diknas dan PT. Raja Grafindo Perkasa.
- Setiadi, Bambang. (2006). *Pendekatan Kuantitatif dan Kualitatif*. Yogyakarta: Graha Ilmu.
- Sugiyono. (2012). *Metode Penelitian Kuantitatif, Kualitatif dan R&D*. Bandung: Alfabeta.
- . (2011). *Metode Penelitian Kombinasi (Mixed Methods)*. Bandung: Alfabeta.
- . (2010). *Metode Penelitian Kuantitatif, Kualitatif dan R&D*. Bandung: Alfabeta.
- . (2009). *Statistika Untuk Penelitian*. Bandung: Alfabeta.
- Wantini, D. (2010). *Improving Students' Vocabulary Mastery Using Realia*. Unpublished Thesis. Surakarta: Universitas Sebelas Maret.
- Wibowo, S. A. (2012). *Increasing Students Vocabulary Achievement through Direct Method at the First Grade of SMP Negeri 2 Gadingrejo Pringsewu*. Unpublished Script. University of Lampung.
- Zainuri, A.M. (2003). *Vocabulary 1*. Jakarta: English Department.

About the Authors

Author 1

Complete Name : Eva Faliyanti, M.Pd.,Bi
Institution : Universitas Muhammadiyah Metro
Email Address : evafaliyanti1980@gmail.com
Education : University-level instructor
Research Interest : English Teaching Methodology

Author 2

Complete Name : Alanda Liantara
Institution : Universitas Muhammadiyah Metro
Email Address : alandaliantara@gmail.com
Education : University student
Research Interest : English Teaching Methodology

IMPLEMENTING CONTENT LANGUAGE INTEGRATED LEARNING (CLIL) AT A HIGHER EDUCATION INSTITUTION

Huzairin¹, Basturi Hasan², Sudirman³

University of Lampung^{1,2,3}

huzairin1958@gmail.com¹

ABSTRACT

This study tries to explore project based content language integrated learning (CLIL) executed at a higher education institution in Lampung Indonesia. The research was proposed based on a mixture of the principle of language integrated learning (CLIL) and the principle of project based learning. The design was implemented for the teaching of English as a compulsory subject at Institute of Technology Sumatera. Quantitative data was obtained from the teaching before and after CLIL model application. While the qualitative data was obtained from the output of language produced by students during the learning process took place. The results showed that project based CLIL English language course at the Institute of Technology Sumatera could work effectively.

Keywords: *content language integrated learning (CLIL), project based, biology, history and economic study programs*

I. INTRODUCTION

In general, the aims of English teaching are to give students additional skills to communicate in the language so that the students can use it to communicate both orally and written. The topics of analysis were focused on language skills: listening, speaking, reading and writing. They include analysis on vocabulary, diction, and structure in relation to the use in the community.

As stated in the previous studies (Huzairin, 2017, 2018) that the needs to master English in the future has become a big challenge for higher education institutions as an institution to produce workers. If we wish to win global competition, higher education institutions must equip its graduates with the ability to communicate in English adequately.

Furthermore, for students having the ability in English will be helpful to assist them in accomplishing their study tasks particularly in reading books written in English. Therefore, in order to answer all challenges above, there need to be upgrading in the teaching of English for non-English department students by using the most appropriate planning of teaching approach. One of the ways is by placing the needs to learn as a central issue in the lesson plan. This is in accordance with English for Specific Purposes ESP in which the learners and their needs become the main consideration in determining the most effective and efficient learning direction (Hutchinson & Waters, 1987; Robinson, 1991). The main target of such an approach is to assist the learners in order to

master English in a short time with high appropriacy in accordance with field of respected study

The problems arise were the limitation of time for classroom face to face in class meeting in the classroom causes the class meeting become less effective for the class with different English ability. In higher education system which require *active learning*, the English instructors often find difficulties to deal with students whose English competence below the average among peers. In fact, English lecturers often find difficulties in assisting students with below average capabilities. In fact the target for teaching English at university level is high enough, i.e to enable students to possess adequate capabilities to master English so that they are able to write in academic English as an international language.

One of the attempts to fulfill students' learning needs is by optimizing all potentials available. For instance, by making use of internet to gather learning material based on the field of studies.

One of the steps taken was to develop Content Language Integrated Learning (CLIL) learning model i.e by integrating learning different subjects with the ability to communicate in English. CLIL is the development of English for Specific Purposes (ESP), which focuses on the learning of English for specific objectives, for instance, for working (vocation) or for academic Purposes.

II. THEORETICAL FRAMEWORK

Project Based Learning

Project based learning is a model of learning organisation in the form of project. Project is a complex learning task which is based on challenging questions or problems which involve learners in designing problem solving, decision making or other investigating tasks, involving learners study individually for a limited time in order to produce realistic products (Jones, Rasmussen, & Moffitt, 1997; Thomas, Mergendoller, & Michaelson, 1999). Stoller (2006) defined learning in project bases as the learning, which has the process and product target. Giving learners the right to owning some projects, lasted in quite longer time (for several weeks or months, to integrate skills, to develop students' comprehensibility toward a topic through the integration of language with other learning subjects, collaborating with other students or self work, assigning new roles for students or lecturers, making the students produced high quality products.

Project based learning is a learning method using problems as the first step in collecting and integrating new knowledge based on experiences in real activities. Project based learning is designed for the use in complex problems needed by students for investigation and comprehensibility.

Project base learning has the following characteristics:

1. Students make a decision on a frame work;
2. There should be problem or challenges directed to the students;
3. Students design a process to determine a decision on the problem or challenge;
4. Students are responsible collaboratively to access and manage information in order to solve problems;
5. Evaluation process is done continuously;
6. Students make reflection continuously;
7. The end product of learning activities will be evaluated qualitatively;
8. Learning situation is full tolerated toward mistakes and changes.

In its application, project base learning model have syntax (steps) specific that distinguish it from other learning models such as *discovery learning model* and *(problem based learning model)*. The steps are: (1) determining basic question, (2) designing the project; (3) Arranging schedule; (4) monitoring the progress of the project; (5) Evaluating results; (6) Evaluating experiences.

Project base learning model always starts by finding the basic question, which later will be used as the basis for assigning students the project they should accomplish. Of course the topic used should relate to the real job. The next step is by the aids from the lecturers, groups of students are designing activities that will be done in their respected teams. The bigger the students' involvement in contributing their ideas, the bigger students' sense of belonging toward the project. Next, students and lecturers determine the time limit to accomplish the project.

III. METHODS

This research implemented Developmental Research. The research was oriented toward product development in which the developmental process was described in detail and the products are finally evaluated. In the teaching of English the developmental research is applied over and over from the design and examination toward learning material products. (Gravemeijer, 1999). The output of the research is high quality products theoretically, methodological procedures and empirically.

Research and development is a strategy to develop effective educational products. The educational research and development is an industry with model developmental in which research inventions are used to develop new products and procedures which is systematically tried out, evaluated, and revised until effective criteria or quality reach particular standard (Gall, Gall and Borg, 2003). The steps and processes of development refers to research and development which consist of studying research inventions related to products being developed, developing products based on scientific findings, try out of designs, revising the products to improve the weaknesses on try out phase. This is because, according to Borg (1979), the intention of research and development is to bridge the gaps that are often found between educational research and educational practice.

IV. RESULTS AND DISCUSSIONS

Content Language Integrated Learning (CLIL) is implemented in several study programs at Institut Teknologi Sumatera as the realisation of 2 credit subject. The subject aims at providing students with the ability to master English with subskills of listening, speaking, reading and writing in English. These skills are expected to able to equip students develop their academic potentials. Formally, English as subject, is taught in 100 minute of learning face to face, structured learnig activities, and self study for 100 minutes. The number of meeting time is 16 meetings in one semester.

For the English subject given for the odd semester 2017/2018, the implementation was devided in to two term: before the mid semester term consists of 8 meetings. Another 8 meetings were implemented for the second term of the session.

In each term, content language integrated learning on project base is organised with different emphasis. To evaluate the students were given tasks related to language skills: listening, reading, speaking, and writing, to complete the langage instruction by the lecturer.

The following table illustrates the descriptive statistcs of the learning results of four lerning results: lab work tasks, speaking task, writing task, and language analysis tasks

Tabel 1 Descriptive statistics of learning results

	N	Minimum	Maximum	Mean	Std. Deviation
Labwork	128	43,00	80,00	67,9063	8,21306
Writing	128	52,00	85,00	71,3646	8,28965
Speak	128	41,67	78,67	66,4489	8,26424
Grammar	128	41,00	80,00	65,7396	8,82967
Valid N (listwise)	128				

Table 1 shows that for lab work tasks the lowest point was 43, the highest point was 80, and the average score was 67,90 sd = 8,21. For writing task, the lowesr score was 52, the hughest score was 85, the mean score was 71,36, sd = 8,28. For speaking task, the lowest point was 41,67, the highest point was 78,76, znd the average score was 66,44 sd = 8,26. For grammar task the lowesr score was 41, the highest score was 80, the maen score 65,73 sd = 8,83.

Analysis of speaking tasks.

In order to answer the question is there any influence of categorizing students into categories toward students' achievement of speaking, Multivariate Analysis of Variance (MANOVA) was applied. The following table shows descriptive statistics of speaking task into four types of learning achievement.

Table 2. Deskriptive statistics os students' speaking achievement

	N	Mean	Std. Deviation	Std. Error	Minimum	Maximum
1,00	28	67,7778	8,76679	1,78951	48,67	78,00
2,00	28	67,1389	9,73113	1,98636	41,67	78,67
3,00	28	66,2681	6,40604	1,30763	51,67	76,00
4,00	28	64,6110	7,97569	1,62803	44,33	77,33
Total	128	66,4489	8,26424	,84347	41,67	78,67

Note: 1 = upper class 1 2 = upper class 2
 3 = lower class 1 4 = lower

Analysis of writing task

In order to answer research question is there any significant influence of learning categories toward the achievement of writing at Institut Teknologi Sumatera, statistical testing Analysis of Variance was undertaken. The result of the calculation is presented in table 3

Tabel 3 ANOVA on qualification on writing task

	N	Mean	Std. Deviation	Std. Error	Minimum	Maximum
1,00	28	71,5833	9,30599	1,89958	53,00	85,00
2,00	28	75,3750	5,80714	1,18538	62,00	85,00
3,00	28	70,5417	7,66686	1,56499	52,00	85,00
4,00	28	67,9583	8,66517	1,76877	52,00	80,00
Total	128	71,3646	8,28965	,84606	52,00	85,00

Analysis learning tasks on grammar analysis

In order to answer the question is there any influence of categorization of learning task on of English grammar analysis at the Institute of Technology Sumatera, Statistical testing Analysis of Variance was conducted with the following results

From a series of statistical analysis, it can be concluded that there is no significant influence of different learning tasks toward the quantity and quality of speaking when involved in the interactions. This can be seen from the F count in statistical analysis in students' amount of speaking (length of time of speaking, number of turns, and C-unit) and also the F count for quality of speaking which cannot be categorized significant because the F value is not $>0,05$. However, even though there is no significant influence of different learning tasks on the quantity and quality of students' speaking, there are still students' speaking ability designed by the researcher with the characteristics of students' achievement.

This finding supports previous study by Brown 1994 who stated that if teachers could give students a kind of assignment suitable to their capability the performance will better. If the students' learning style is suitable with instructional style, motivation, their performance and achievement will increase.

There are some important findings from the research. Among others are: project base CLIL on English subject at Institut Teknologi Sumatera could run well. This is proven from the overall application of programs from the establishment of study groups, students work in groups to accomplish the project well. Group presentation, personal presentation, and personal responses activities were done in English.

From a series of statistical analysis, it can be concluded that there is no significant influence of different learning tasks toward the quantity and quality of speaking when involved in the interactions. This can be seen from the F count in statistical analysis in students' amount of speaking (length of time of speaking, number of turns, and C-unit) and also the F count for quality of speaking which cannot be categorized significant because the F value is not $>0,05$. However, even though there is no significant influence of different learning tasks on the quantity and quality of students' speaking, there are still students' speaking ability designed by the researcher with the characteristics of students' achievement.

This finding supports previous study by Brown 1994 who stated that if teachers could give students a kind of assignment suitable to their capability the performance will better. If the students' learning style is suitable with instructional style, motivation, their performance and achievement will increase.

There are some important findings from the research. Among others are: project base CLIL on English subject at Institut Teknologi Sumatera could run well. This is proven from the overall application of programs from the establishment of study groups,

students work in groups to accomplish the project well. Group presentation, personal presentation, and personal responses activities were done in English.

IV. CONCLUSION AND SUGGESTION

From the description of the results of research and the analysis, it can be concluded that: a) There is a significant influence of Project based Integrated Language Learning toward the fluency and accuracy of English by students at the Institute of Technology Sumatera. This was proofed by significant difference between students' ability before and after the application of Project based Integrated Language Learning. b). Students' responses toward the teaching of English through Project based Integrated Language Learning were positive. This is evidenced from the students' responses through questionnaire answers before and after the application of the language program.

Based on the results of the research, some suggestions are proposed: Teaching English at higher education level are suggested to accommodate students' needs toward better quality of English teaching at higher education institution. Teaching and learning activities proposed should be able to accommodate students' need of learning English at higher education institutions.

REFERENCES

- Anderson, L. W., & Krathwohl, D.R. (Eds). (2001). *A taxonomy for learning, teaching, and assessing: A revision of Bloom's taxonomy of educational objectives*. New York: Longman.
- Bentley, K. (2010). *The TKT course CLIL module*. Cambridge: Cambridge University Press.
- Coyle, D. (2007). Content and language integrated learning: Towards a connected research agenda for CLIL pedagogies. *The International Journal of Bilingual Education and Bilingualism*, 10, 543-562.
- Coyle, D., Hood, P., & Marsh, D. (2010). *CLIL: Content and language integrated learning*. Cambridge: Cambridge University Press.
- Johnson, D. W., Johnson, R. T., & Holubec, E. J. (1994). *The new circles of learning: cooperation in the classroom and school*. Alexandria: Association for Supervision and Curriculum.
- Kagan, S. (1992). *Cooperative learning*. San Juan Capistrano, California: Kagan Cooperative Learning.
- Lorenzo, F., Casal, S. and Moore, P. (2010). The effects of content and language integrated learning in European education: Key Findings from the Andalusian Bilingual Section. Evaluation Project. *Applied Linguistics*, 31, 418-442.
- Lasagabaster, D. (2008). Foreign language competence in content and language integrated courses. *The Open Applied Linguistics Journal*, 1, 31-42.
- Lasagabaster, D. (2011). English achievement and student motivation in CLIL and EFL settings. *Innovation in Language Learning and Teaching* 5(1), 3-18.
- Jones, B. F., Rasmussen, C. M., & Moffitt, M. C. (1997). *Real-life problem solving: A collaborative approach to interdisciplinary learning*. Washington, DC: American Psychological Association.

- Miller, P. C. 2006. Integrating second language into project-based instruction. In *project-based learning in second and foreign language education: Past, present, and future*, ed. G.H. Beckett and P.C. Miller, 225–40. Greenwich, CT: Information Age
- Stoller, F. 2006. Establishing a theoretical foundation for projectbased learning in second and foreign language contexts. In *Projectbased second and foreign language education: Past, present, and future*, ed. G.H. Beckett and P.C. Miller, 19–40. Greenwich, CT: Information Age
- Thomas, J. W. & Mergendoller, J. R. (2000). Managing project-based learning: Principles from the field. Paper presented at the Annual Meeting of the American Educational Research Association, New Orleans.
- Thomas, J. W., Mergendoller, J. R., and Michaelson, A. (1999). *Project-based learning: A handbook for middle and high school teachers*. Novato, CA: The Buck Institute for Education.
- Hadley, A. O. (2001). *Teaching Language in Context Third Edition*. Boston, MA: Heinle and Heinle Thomson Learning
- Huzairin, et al 2017. Pengembangan Model Pembelajaran Bahasa Inggris Content And Language Integrated Learning (Clil) Berbasis Project Mata Kuliah Bahasa Inggris Di Perguruan Tinggi. Laporan Penelitian. Universitas Lampung.
- Joyce, B., Weil, M. & Calhoun, E. (2000). *Models of Teaching Sixth Edition*. Boston: Allyn and Bacon.
- Krashen, S. D. (1981). *Second language acquisition and second language learning*. New York: Pergamon.
- Krashen, S. D. (1982). *Principles and Practices in Second Language Acquisition*. Oxford: Pergamon.
- Kumaradivelu, B. (2001). Toward a Postmethod Pedagogy. *TESOL Quarterly*, 28, 27-48.
- Robinson, R. D., McKenna, M. C., dan Wedman, J. M. (Eds.) (2000). *Issues and Trends in Literacy Education Second Edition*. Needham Heights, MA: Allyn and Bacon.

STUDENTS' DIFFICULTIES OF WRITING AN ESSAY

Rulik Setiani¹, Dewi Sri Kuning²

STKIP Muhammadiyah Kotabumi^{1,2}

Jl. Hasan Kepala Ratu Sindang Sari No.1052 Kotabumi-Lampung Utara

ABSTRACT

Writing is an activity in delivering ideas or thoughts into written form, writing is also one of the language skills that must be mastered by students besides listening, speaking and reading. Writing also depicts graphic symbols that produce a language that is understood by someone so that other people can read the graphic symbols and can understand of them. While the essay is a form of writing consisting of several paragraphs; introductory paragraph, body, and concluding paragraph. Then the process of writing an essay includes Prewriting - Planning - Writing and revising the draft - Final copy. Some difficulties or problems that are often faced by students in writing an essay include the first is linguistic problem, namely difficulties /problems in language structure, sentence structure, and the problem diction. The second is cognitive problem, including: punctuation problem, capitalization, spelling, content, and the last is organization problem.

Keywords: *student difficulties, writing an essay*

I. INTRODUCTION

Writing is one of the skills that should be mastered by the English language learners. Generally, writing is a way in sending message from the writer to the reader. According to Leo (2007:1), writing is process of expressing idea. According to Tarigan (2008:3), additionally writing is ability to communicate indirectly not face to face and also including in productive activity. Additionally, Writing is not easy because it needs hard thinking to prduce words, sentences, and paragraph at the same time. From the explanation above, writing is a complex skill in expressing the idea and feeling of the writer in the written form, the writer can deliver idea and feeling to the readers, so the readers will be able to understand what the writer means.

In addition, Warnock (1989:24) stated that writing is not only needs a patience of many hours to write correctly, but also the writer must invite the readers to feel what is part of them. To sum up writing is a complex skill because the writer must be able to arrange something abstract to be concrete form. According to Brown (2004:244), there are five general components in writing they are: content, organization, vocabulary, grammar, and mechanics. The first component is content, content is the substance of the writing idea expressed. Content needs the writing to be focused on the ability to think creatively and develop thought, content consists of introduction, body, and conclusion. The second component is organization, organization explains about ideas, coherence and cohesion, logical squencing, controlling idea and relationship of ideas and between paragraph. The third component is grammar, correct grammar is very important in writing, when the

writer writes his/her writing, he/she has to be able to write correctly and appropriately sentences, grammar is the employment of grammatical form and syntactic patterns. Grammar explains about verb, tenses, pronoun, preposition, effective complex, construction, number, and word order. The fourth component is vocabulary, using appropriate vocabulary is very considered in writing, vocabulary shows amount the accuracy vocabulary, idiomatic expression, word forms and appropriate register and diction. The usages of vocabulary are precise, use of parallel structures, concise, and register well. The last component is mechanics, mechanics consists of spelling, punctuation, and capitalization.

From the statements above, it can be concluded that writing is a process to express ideas into the written form, writing is a tool to send message from the writer with the other people. writing is not easy because writing as a process to get a written product influenced by some aspects such as organization, vocabulary, grammar, content, and mechanic. Therefore writing needs hard work to construct a critical thinking to persuade the readers when they read.

According to Oshima and Hogue (1991:100), “an essay is a piece of writing several paragraphs long instead of just one or two paragraphs and written about one topic, just as a paragraph is. However a topic of an essay is too complex to discuss in a paragraph. Therefore, it must be divided into several paragraphs, one each major point. Then must tie all of the separate paragraphs together by adding an introduction and conclusion”.

Oshima and Hogue (2007:150) said that there are three parts of an essay, such as introduction, body, and conclusion. An essay introduction stimulates the reader's interest and tells what the essay is about. The last sentence of an introduction is the thesis statement. Like the topic sentence of a paragraph, a thesis statement names the specific topic of the essay. The body consists of one or more paragraphs. Each paragraph develops a subdivision of the topic, so the number of paragraphs in the body will vary with the number of subtopics. The body is the longest part of the essay and can contain as many paragraphs as necessary to support the controlling ideas of the thesis statement. Each body paragraph has a topic sentence and several supporting sentences. It may or may not have a concluding sentence. Each body paragraph supports the thesis statement. The conclusion, like the concluding sentence in a paragraph, is a summary or review of the main points discussed in the body. An essay has unity and coherence, just as a paragraph does. The first part of the concluding paragraph summarizes the main points or repeats the thesis statement in different words. It may require one or more than one sentence. In the second part, you may add a final comment. This is the place to express your opinion, make a judgment, or give a recommendation. However, do not add any new ideas in the concluding paragraph. Just comment on what you have already discussed. Transition signals link the paragraphs into a cohesive whole. It can be concluded that writing an essay is writing a piece of several paragraphs that include of introductory paragraph, body, and concluding paragraph.

II. DISCUSSION

Writing Process

Writing basically is not easy, can not be said as a product but need to take a study and more practice so it is necessary to say that writing is a process not product. If someone wants to write something and he/she wants to make a perfect piece of writing, he/she has to know the process of writing. Not all writers write in the same way, but experienced writers can point to particular elements that generally occur in the act of writing, even though these elements may be combined in different ways. According to Oshima and Hogue (2007:15-19), there are four phases in the process of writing. They are: Prewriting – Planning – Writing and revising draft – Final copy. The explanation of them can be seen as follows.

Prewriting

Prewriting means the activity does before writing something. In the prewriting, there consists several steps. First, the writer needs to choose and narrow a topic. When the writer is given a free topic of discussing and allows to have long writing, the writer needs to narrow the topic into a particular subject. The writer should consider when the topic is still too broad, he/she must narrow the writing.

The point is to create writing clearly, completely, and effectively. Second is brainstorming. sometimes this step is seen unnecessary, but after doing in many times the writer will realize that it is very beneficial, brainstorming can help to begin the writing faster and save you time in the later stages of the writing process (Oshima and Hogue, 2007:4). Three useful brainstorming techniques are listing, freewriting, and clustering. Listing is a brainstorming technique in which you think about your topic and quickly make a list of whatever words or phrases come into your mind. Your purpose is to produce as many ideas as possible in a short time, and your goal is to find a specific focus for your topic. Freewriting is a brainstorming activity in which you write freely about a topic because you are looking for a specific focus. While you are writing, one idea will spark another idea. As with listing, the purpose of freewriting is to generate as many idea as possible and to write them down without worrying about appropriateness, grammar, spelling, logic, or organization. Clustering is another brainstorming activity that you can use to generate ideas. Here is how to use this technique; in the center of your paper, write your topic and draw a “balloon” around it. Then write whatever ideas come to you in balloons around the core

Planning

Planning is something has been thought. The step is still the continuance from brainstorming, the step of brainstorming is doing by listing (outline). This step is also called by grouping (Oshima and Hogue,1991:11). In planning, the writer needs to consider three points, they are the objective of the writing, the reader they are writing for, and also the content of structure to series the fact.

Writing and Revising Drafts

This is first effort for students to write their ideas. It means students write tentative because there are several steps done later after this stage. According to Rofi'i (2017:10),

students just write without paying attention with the errors in this phase. Therefore, when reading the final writing, do not be surprised if it still needs some changes because writing is a sustainable process and always needs prewriting or revising to be good writing (Oshima and Hogue, 1991:13).

Final Copy

The last stage of writing process is final copy. In this stage, the writer produces a final copy that may be different from the beginning writing and after revising. All the process above cannot be separated because those are compiling a good written text.

Types of Writing

Writing is a complex and sometimes difficult to teach. Requiring mastery of gramatical, conceptual and judgemental element is necessary. Teacher should pay attention in many elements to evaluate students writing, such as grammatical, vocabulary, continuity and others. According to Brown (2003:220), there are four types of writing performance namely imitative, intensive (controlled), responsive, and the last is extensive. Each of the types have different categories.

The first is imitative. In this type, student just imitates English letters, word and possible sentences so that the students can learn the covention of the orthographic. This stage includes the ability to spell correctly and correspondence of phoneme grapheme in English spelling system. In this level, student tries to master the writing mechanics. The form is primary but the content and the meaning are of secondary concern. This stage is usually at beginning level.

The second is intensive or controlled. In this stage the assessments are more concerned in the focus on form. The student should reache skill in producing appropriate vocabulary in a context, collocation, idiom, and correct grammatical features.

The third is responsive. This stage enables the student to perform a limited discourse level. Connecting sentence into a paragraph and creating logically connected sequence of two or more paragraph. Finally, the students should master the fundamental of sentence level grammar. This stage more concern on the discourse convention that mostly emphasis on the context and meaning.

The fouth is extensive. This stage focuses on the achieving an objective, organizing and developing ideas logically, using detail to support or illustrate ideas, demonstrating syntactic and lexical variety. Focus grammatical form is limited to occasional editing or proof reading of a draft.

Component of Writing

To begin writing, the writer has to follow some components of writing. According to Brown (2004:244-246), there are five general components in writing namely, organization, content, vocabulary, grammar, and mechanics. The following is the writing components explanation:

Organization

Organization contains the well-matched in writing that is unified. By using organization concept, the students are arranging their idea become coherence with content. Coherence has means that the relation among sentence is interrelated.

Content

Content consist of understanding knowledge of topic and the development sentence that have interrelationship. In the content, students can deliver their concrete idea that must be written by unity formed. Unity is related to writing ideas in the text which reproduce the writer's information to transfer to the reader.

Vocabulary

Students use vocabulary when they write about the topic. This component must be used correctly and suitable with content. The choice of vocabulary should consider topic of the the text in order the reader understand the meaning from the text easily.

Grammar

Grammar has important role writing because can influence the assessment value of writing. Grammar which will be evaluated in writing must appropriate with the topic of writing, for example; when the teacher will evaluate grammar in writing descriptive text, so the students use present tense.

Mechanics

Mechanics evaluate the technique for achieving a well handwriting, in mechanic component, there are several components that will be evaluated such as: punctuation, spelling and capitalization.

Based on the explanation above, it can be concluded that writing is very complex skill involving several components that must be mastered by students to have good ability in writing, it is important to students to master all components of writing.

Concept of Learning Difficulties in Writing an Essay

Writing is a part of four integrated skills in English learning that should be learned by students. Writing is a process to get product. The final product is measured against a list of criteria, students are expected to master the aspects in writing includes, content, organization, vocabulary use, grammar use, and mechanical consideration such as spelling, and punctuation. According to Harmer (2007:30), writing is difficult skill for native speakers and non-native speakers, because writers must be able write it in multiple issues. Additionally Richard (1997:100) say that learning to write well is very difficult and lengthy process, because it induces anxiety and frustration in many learners.

There are many problems that make students feel difficult when they are doing the writing task. Students' problem in writing may occur because of many factors. According to Alfaki (2015:44), difficulties in writing consist of linguistic and cognitive problem. The explanation is as follows:

Linguistic Problems

According to Alfaki (2015:43), in writing, the writers have to compensate for the absence of these features: they have to keep the channel of communication open through our own efforts and to ensure, both through our choice of sentence structure and by the way our sentences are linked together and squeezed, that the text produced can be interpreted on its own. Alfaki (2015:44) explained that linguistic problem in writing are: grammatical problem, sentence structure problem, and problem of diction. Those problem are described below:

Grammatical Problem

The first problem of linguistic is grammatical problem, this problem is often faced by students in writing English. Brown (2004:20) stated that grammar is system of rules governing the conventional arrangement and relationship of words in a sentence. Based on Latief and Mukminatien in Cahyono (2002:132), students have problem with subject-verb agreements, article, pluralization, and complex sentence.

Sentence Structure Problem

A good sentence has a function to deliver the information. Bad sentence or jumble sentence will make someone difficult to understand the information. The problem that face by students is sentence structure in second language is different, and usually sentence structure make students confused. According to Kharna in Alfaki (2015:47), students who have problem of sentence structure are unable to produce longer sentences requiring subordination and coordination.

Problem of Diction

Delivering the information not only from sentence, but also word choice also determining in the written form. Norrish in Alfaki (2015:45), said that a good writing or composition should consist of appropriate and varied range of vocabularies which are used with proper grammar and varied range of sentence structures. According to Reid in Melese (2007:13), the writers should choose the appropriate vocabulary in order to the readers comprehend the purpose of writing it self.

Cognitive Problems

According to Alfaki (2015:44), the writers have to master the written form of the language and to learn certain structures which are less used in speech, or writing. We also have to learn how to organise our idea in such as way that they can be understood by the reader who is not present and perhaps by a reader who is not known to us. Alfaki (2015:45), said that cognitive problem in writing are: punctuation, capitalization, spelling, content and organization. Those problem are describe below:

Punctuation Problem

According to Byrne (1988: 16), the fact that punctuation has never been standard to the extent as spelling, it makes problematic. Similarly, Carrol and Wilson in Alfaki (2015:45) states "students' writing encounter punctuation problems as there are no universal rules of punctuation.

Capitalization Problem

Capital letters are useful for sentence initials, the beginning of important words, in topics, headings. According to Kroll in Alfaki (2015:45), however, learners have problems in using capitalization properly. There are reasons for students' problems in using proper capitalization. "The rules of capitalization are not universal and classifying nouns as proper and common nouns is difficult for students" Gowere et al in Alfaki (2015:45).

Spelling Problem

Due to the influence of other languages, variant pronunciations and other historical reasons, the English spelling system which has become inconsistent is complex for students. (Gowere et al in Alfaki, 2015:45).

Content Problem

Learners of English as a second or foreign language also face problems of exploring ideas and thought to communicate with others (Clifford in Alfaki, 2015:46). Furthermore, Leki in Alfaki (2015:46) said that this could be because of the traditional methods teachers use to teach writing for spelling, punctuation, and mastering grammar. Clifford in Alfaki (2015:46) suggests that teachers should encourage students to focus on the message, ideas or thoughts they wish to convey rather than grammar, spelling, punctuation and others.

Organization Problem

According to Kharma in Alfaki (2015:46), learners have the problem of structuring the paragraph, topic development of a paragraph, structuring the whole discourse and a theme in a discourse. "The most common students' problem in paragraphing is either the paragraph is not limited to a single topic or the single topic is not developed or exemplified adequately" West in Tsegay (2006:17). In line with the theory from Raimes in Alfaki (2015:46) states that the other problem of organization in student' writing is the difficulty of differentiating a topic and supporting ideas or generalizations and specific details.

III. CONCLUSION

In writing an essay especially in writing an English essay, sometimes the students often face difficulties or problems such as linguistic problem and cognitive problem. Linguistic problem consists of grammatical problem, sentence structure problem, and dictation problem, and cognitive problem consists of punctuation problem, capitalization problem, spelling problem, content problem, and organization problem.

REFERENCES

- Alfaki, M Ibrahim. 2015. University students' English Writing Problem: Diagnosis and Remedy. Dalam *International journal of English Language Teaching*. Vol. 3(3): 40-52.
- Brown, H. Douglas. 2004. *Language Assessment Principles and Classroom Practice*. USA: Longman.
- Harmer, Jeremy. 2007. *How to Teach English New Edition*. England: Person Longman.
- Leo, Sutanto. 2007. *Essay Writing*. Yogyakarta: CV Andi Offset.
- Oshima, Alice and Hogue, Ann. 2007. *Introduction to Academic Writing Third Edition*. New York: Pearson Longman.
- Oshima, Alice and Hogue, Ann. 1991. *Writing Academic English*. New York: Addison-Weisley Publishing Company.
- Rofi'i, Agus. 2017. Improving Students' Motivation in Writing Descriptive Text by Using Mind Mapping Technique. Dalam *journal ELT-Echo*. Vol. 2: 147-152.
- Tarigan, Henri. Guntur. 2008. *Menulis Sebagai Suatu Keterampilan Berbahasa*. Bandung: Percetakan Angkasa.
- Warnock, Tilly. 1989. *Writing Is Critical Action*. United State of America: Scott, Foresman and Company.

THE CONCEPT OF MEANING

Cucu Sutarsyah

University of Lampung

cucusutarsyah@gmail.com

ABSTRACT

The concept of meaning becomes very important aspect to discuss when analyzing the nature of reading. Reading is a process of getting meaning of printed media produced by the writer. It focuses on the construction of general theory to the nature of language in terms of semantic, the theory of meaning. It is said that semantic component should meet three conditions as word meaning, sentence meaning, and the situation. This article deals with analyzing the theories meaning related to word, sentence, and ambiguity. It provides an intellectual frame of reference that can be used by investigators to approach how the students comprehend English texts by understanding the concept of meaning.

Keywords: *dictionary meaning, individual meaning, ambiguity*

I. INTRODUCTION

Reading is actually getting meaning from printed form. In fact, describing the concept of meaning is not as simple as what most people think. There are many variables that involve in the process of deciding the meaning of a word or sentence, and even in paragraph and longer text. The notion of meaning has been discussed in terms of reading difficulty in the previous section. This article is focused on the process of getting meaning when one is reading.

The investigation of the concept of meaning is generally begun from the theory of semantic as a part of general linguistic theory that is scientific in the sense that it makes empirical testable predictions (Kempson, 1984). That is to say that a theory is said to be scientific if it can be tested based on empirical data. However, linguistics as science is concerned not with the mere collection of facts, but with the construction of a system of abstract concept which will account most adequately for the particular properties which language display.

In order to have any claims of adequacy, Kempson (1984:4) asserts that a semantic theory must have at least three conditions.

- (1) It must capture for any language the nature of word meaning and sentence meaning, and explain the nature of the relation between them;
- (2) It must be able to predict the ambiguities in the forms of a language, whether in words or sentences;

- (3) It must characterize and explain the systematic relations between words and between sentences of a language – i.e. it must give some explicit account of the relations of synonymy, logical inclusion, entailment, contradiction, etc.

If a theory fails to capture these relations, either at all or in particular cases making the wrong prediction, it must be inadequate, either in principle or in some detail of the theory. She further points out that all languages depend on words and sentences. In other words, every word and every sentence conventionally associated with at least one meaning. Accordingly, for any one language, our semantic theory must be able to assign to each word, the meaning associated with it in that language.

In the case of words, these basically deal with dictionary meaning, that is, individual meaning of words apart from sentence. But in the case of sentences, the problem is more complex. In any language, words are arranged into sentences and that the meaning of these sentences depends on the meaning of the words it contains even though it is not as simple as it is. *Dogs like to chase cats* is different from *Cats like to chase dogs* even though the two sentences consist of the same words, they do not mean the same.

Therefore, a semantic theory has not only to capture the exact nature of the relation between word meaning and sentence meaning, but it must be able to state in what ways this relation is dependent on word-order or other aspects of the grammatical structure of sentences (Kempson, 1984: 3)

Furthermore, both words and sentences can be ambiguous in different ways and this may confuse the reader to get the intended meaning (Nation, 2005). The word “bank” in *John has gone to the bank* is ambiguous for a reader without looking at the preceding and following sentence or without any clear clue. The word “bank” may have two meanings, that is, ground near a river and an established place for keeping money. On the other hand, at the sentence level, the sentence *Flying planes can be dangerous* has no ambiguous word but the sentence itself is ambiguous. What can be dangerous, the act of *flying* or the *planes*? In this case the ambiguity is due to the structure dependent on whether the *planes* is understood as the subject of the verb flying or as the object (Kempson, 1984).

However, if there is a noun marker in front of the word “planes” or infinitive “to” in front of the word “flying”, then, there seems to be no problem.

Flying a plane can be dangerous.

To fly a plane can be dangerous.

To fly planes can be dangerous.

These three sentences are not ambiguous because there is no other possible interpretation of the noun phrase.

In addition to the concept of meaning, Firth in Coulthard (1989:1) points out that language is only meaningful in its context situation. He asserts that the descriptive process must begin with the collection of a set of contextually defined homogeneous texts and the aim of description is to explore how the sentences or utterances are meaningful in their contexts. Therefore, the main concern of descriptive linguistics is to make statements of meaning. Linguists cannot define meanings, but must appeal for this to common knowledge (Bloomfield, 1933).

To show that context situation is important, Coulthard (1989) gives an interesting illustration. The sentence *I am hungry* can depend on its context situation and therefore can be used for different purposes; it can be used by a starving beggar to request food or by a petulant child to delay going to bed. Bloomfield (1933) argued that linguistics is only concerned with those phonological, lexical and syntactic features which the utterance share. It was no concern of linguistics to explain how identical utterances can have different functions in different situations, nor how listeners correctly decode the intended message.

Other relation is called entailment (implication) and contradiction (Kempson, 1984), which means that one sentence entails the second sentence. If the first sentence is true, it implies that the second is also true. For example, *Paul passed the test, Paul got a certificate*; similarly, *Simon has just built our house, We have a house*; *Tom is walking, Tom is moving*, etc. Again, the corresponding relation of words is logical inclusion. The meaning of *girl* logically includes the meaning of *human*, because to say that something is a *girl* implies that it is a *human*.

So far, we have looked at the construction of general theory to the nature of language in terms of semantics, the theory of meaning. It is said that semantic component should meet three conditions as described. The following discussion deals with word meaning and sentence meaning in more detail. Ambiguity and vagueness are also discussed to complement the understanding of the concept of meaning. Most of the discussion concerns with a brief outline of the account provided by Kempson (1984).

II. DISCUSSION

Word Meaning

In previous section, the nature of word meaning and sentence meaning has been discussed together with some conditions that should be met. To construct the explanation of meaning in natural language, linguists, according to Kempson (1984) have three main ways: (1) by defining the nature of word meaning, (2) by defining the nature of sentence meaning, and (3) by explaining the process of communication.

In the first point there is clear relation between words and objects because a word is used to refer to objects, and actions, and explanation of this relation is the task of semantics to explain. Similarly sentences are used to describe events, beliefs, opinions, and it is the task of

semantics to explain the nature of the relation between sentences and the states of affairs those sentences describe and finally interpretation of language should be explained in terms of its role in communication.

To illustrate these three aspects of meaning, word meaning, sentence meaning and communication can be seen from the uses of the word “mean” (Kempson, 1984:12) as the following:

- (a) (1) Spinster *means* unmarried
(2) To earn *means* to receive money in return for work
- (b) (3) The sentence Brian murdered Mary *means* that someone called Brian deliberately killed someone called Mary.
- (c) A: Are you not doing anything?
B: What do you *mean*?
A: I *mean* I want you to help me with this heavy box.

The uses of the word *means* in (a) and (b) are basically the same, that is to *indicate* similar idea, but *means* in (a) is used in word meaning, while (b), sentence meaning. In contrast, in illustration (c) the word *means* is used in different sense. The word “means” here is used between two speakers to indicate *intention*. Thus, the word is used as *I intend to indicate or to say*.

Furthermore, the meaning of a given word depends on the other words with which it forms a sentence as well as on its position within the sentence (Harris and Smith, 1986). Hence, longer utterances (phrase and sentences of which individual words are a part) provide keys to word meanings and also determine word usage (Wardough, 1975)

Furthermore, in describing the concept of meaning, it is worthwhile to look at the term reference in relation to meaning. The relationship which holds between word and things is the relationship of reference (Lyons, 1968 in Brown and Yule, 1985). According to traditional semantic view, reference is one in which the relationship of reference is taken to hold between expression in a text and entities in the world and that of co-reference between expression in different parts of a text. It is used to discuss lexical meaning (Brown and Yule, 1985:204). In other words, reference shows a one-to-one correspondence between name and object, between *signifiant* and *signifie*. Take for example, the signifiant *cat* is partially determined by its sense, that is, the component properties of animate, fur covered animal often kept as a pet. The name of *Beehive* refers to the object of parliament building in Wellington, New Zealand; but in US, it refers to a different thing. This relationship between words and objects called relationship of reference (Kempson, 1984). Moreover, according to van Dijk (1977:45) reference may be identical, i.e., terms may denote the same individual, but only under some further conditions. Similarly, the reference also changes and these changes must follow certain constraints. However, this is not only the case of reference to individuals, but typically holds for ‘reference’ to properties and relations between

individuals. In the reference to individuals and to properties and relations, the interpretation of sentence will depend on their interpretation of preceding sentences. That means it is not only the interpretation of relative to a model but also with respect to a set of sequence of previous sentence. Therefore, a discourse semantic essentially deals with formulating conditions of relative interpretation.

It is clear that, the meaning of a word can be explained in terms of relation between that word and object or objects to which it refers. Just like proper name refers to individual, it has been said, common nouns refer to set of individual, verbs refer to action; adjective refers to properties of individual, and adverbs to property of actions. However, the problem arises in a large number of cases following verbs such as *like, hope, want*, etc. It is difficult to provide an analysis of their reference. The same thing occurs for a number of abstract nouns and adjectives such as *belief, honest, honesty, intention*; and some other structural words like *but, of, the, on*, etc.

According to Bolinger (1975), sometimes it is hard to prove whether there is a single very abstract meaning or a set of relatively more concrete ones tied together in a bundle. He then clarifies by taking the word “own” as in “your own” which might be encountered in any of the following three situations (191)

- 1) A customer goes to a roadside stand to buy vegetables. He points to some heads of cabbage and says, *Are these your own?* Interpretation: “Did you grow them yourself?”
- 2) A census taker queries a householder: *Is this house your own?* Interpretation: “Do you have title to it?”
- 3) A den mother at a Boy Scout jamboree where there are several other den mothers, each with her flock of boys, points to two boys and asks one of them, *Are these your own?* Interpretation: “Are these your offspring?”

We can see that the possession of *your own* is interpreted differently, but we can still test the meaning of the possession by leaving out “own”. In the first example, the utterance *Are these yours?* still can be used, but it could be taken into this sense *Are they your property?* In the second sentence, the question *Is this yours* is still acceptable, but it is more likely to mean as asking: *Is this where you live?* The last, with *Are these yours* could mean: *Are these two among the boys assigned to you?* Thus, we can see that there is option of defining *one’s own*. The possession *own* is a function word, and function words tend to acquire abstract homogeneous meaning.

In addition, Brown and Yule (1985) have an important idea in discourse representation. They discussed an analytic distinction between what is in the world and what we might describe as the representation in the mind of a person of what is in the world. In other words, when paying attention to a particular piece of discourse, as a sample of experience of the world, the individual may build a specific representation of this particular expression of his particular

experience of the world which, of course, will be integrated, to a degree, within his more general representation of the world (p. 206).

This is to suggest that when a writer produces a piece of discourse, it will be based on his individual representation of a particular state of affairs. When receiving the discourse, the reader will normally try to build a representation (his model) of the state of affairs communicated by the writer. Therefore, the state of affairs might be different among the writer and the reader. This is what we call writer's version and reader version. This basic version allows us to see that there is likely to be inherent mismatch between the writer's representation and reader's representation.

In order to do this, the reader must operate with some regular notion of what type of expressions, under what conditions, are used to refer to entities (Brown and Yule, 1985: 208). Finally, it should be taken into account that the ultimate goal of reading is to get meaning from print. The flow of meaning in a passage or a story is really more important than the individual words (Harris and Smith, 1986).

Sentence Meaning

Although word meaning and sentence meaning are closely related, they can be discussed separately. What is true is that the relation between lexical and sentence meaning and the problem of the extent of the interdependence of syntax and semantic are closely linked that they are virtually one and the same problem (Brown and Yule, 1985). Any effort to analyze sentence meaning we need to discuss syntactic generalization which are stated in terms of two syntactic levels, deep structure and surface structure (Chomsky, 1965). Surface structure is a term used in the study how grammar is constructed in order to generate infinite number of sentences of which language is made up. While deep structure was defined by Chomsky (1965) to be

- (1) the output of the phrase structure rules (i.e. it was the level at which phrase structure rules could be used to state generalizations about the syntactic structure of a language)
- (2) the input to the set of transformational rules (which state the relationship between this level and the surface string of elements making up the sentence)
- (3) the level at which relations such as subject and object were defined (deep structure was the level at which *John persuaded Bill to leave* and *John promised Bill to leave* could be structurally distinguished)
- (4) the level at which lexical items were inserted (i.e. syntactic generalizations in the form phrase structure rules and transformational rules concern either lexical items as a group or lexical items, but not such minimal unit as semantic components),
- (5) the level at which ambiguity in sentences was captured, by assigning a different deep structure corresponding to each interpretation a sentence has.
- (6) the level of deep structure was said to be the input to the semantic component (in Kempson, 1984: 161).

Furthermore, the rule of grammar is often reflected very indirectly in the actual surface structure of the speech (Littlewood, 1989). For example the surface structure of *John is easy to please* looks identical to that of *John is eager to please*. But their deep structure is completely different. Other similar case, as it has been mentioned, can be found in the following two sentences, taken from Kempson (1984):

John persuaded Bill to go
John promised Bill to go

The surface structure of these two sentences looks identical in that they contain a subject noun phrase, main verb, an object noun phrase and a following non-finite verb. The difference in the deep structure of each sentence is the structural relationship between these items. In the first sentence, the object noun phrase (*Bill*) is understood as the subject of the following non-finite verb (*to go*). Thus, *Bill* is expected to go; but not in the second sentence. In the second sentence, it is *John* as the subject noun phrase that is expected to go.

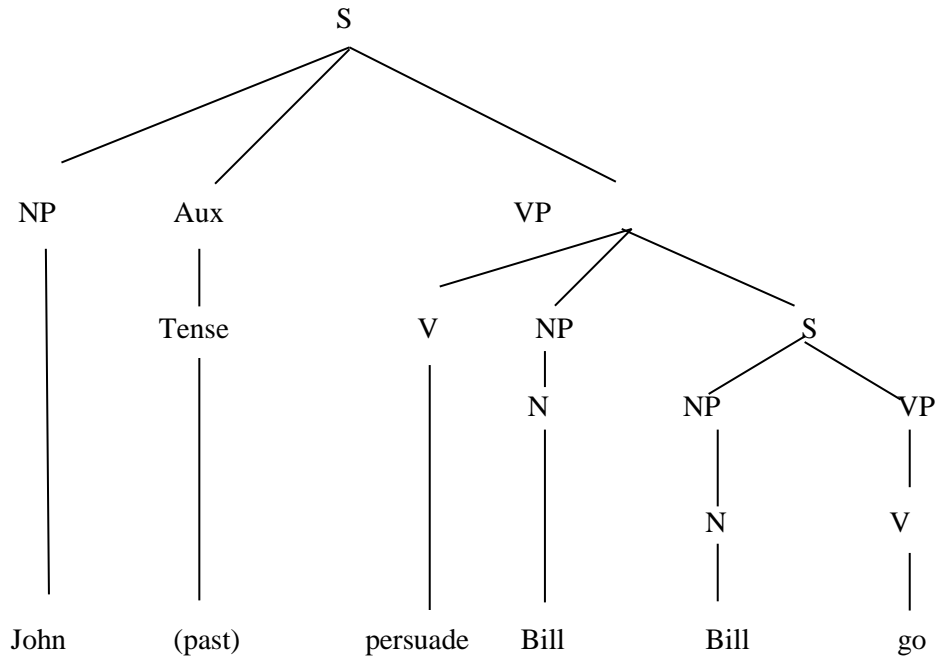

Figure 1 The structure of “John persuaded Bill to go”

Furthermore, Kempson argues that if we are to give structural account of subject object relations in the sentences, then the distinction between these two sentences requires a level more abstract than the sentences themselves at which phrase structure configuration contain distinguishing structural features. The distinction can be illustrated in Figure 1 and Figure 2. The two figures are structurally specified that, as has been mentioned, the subject of *go* differs in the two cases. What we need here is to state the precise relation between this structure and the sentence itself.

Yet, a considerable body of argument is still found especially at the level of deep structure where subject and object relation is stated. The sentence *I want to go* clearly shows that the pronoun “I” functions the subject of non-finite verb “go” (Figure 3). But the case is different when the sentence has another object, for example, *Bill*, as in *I want Bill to go*.

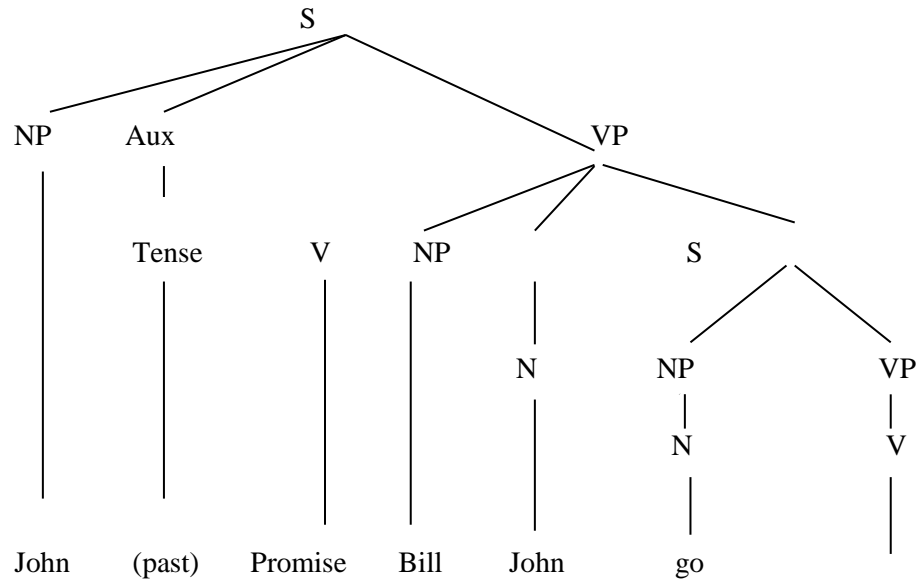

Figure 2 The structure of “John promised Bill to go”

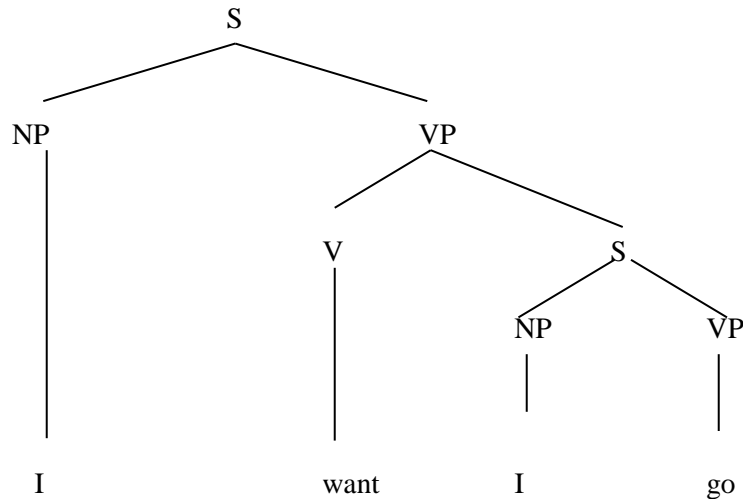

Figure 3 The structure of “I want to go”

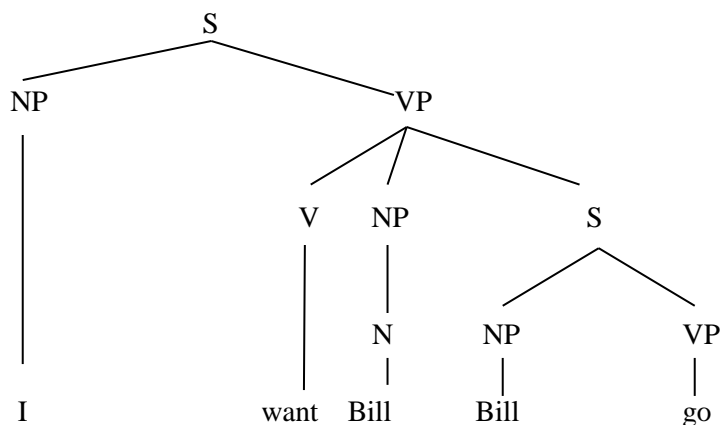

Figure 4 The structure of “I want Bill to go”

The two sentences *I want to go* and *I want Bill to go* have their contrasting subject of “go” specified at that level, the subject of non-finite verb (to go) in the second sentence is “Bill”. These two different structures can be illustrated in Figure 3 and 4.

So far the concept of meaning at the level of sentence has been discussed. To do this the two levels of approaching meaning should be discussed. The two levels are called surface structure and deep structure. One is dealing with grammatical form of sentence as prescribed rule. And the later is the underlying meaning beyond the form of the sentence.

Ambiguity

Ambiguous word or sentence is a word or sentence whose meaning is doubtful or uncertain. Ambiguity is the expression that can have more than one meaning. It is believed that ambiguity is one of the factors that make a reader have difficulty in getting the message in written text.

As previously mentioned, both word and sentence can have more than one meaning. Semantic rule linguists set up must state correctly for each language which words or sentences have more than one meaning. In other words, semantic rule must be able to identify the ambiguous words or sentences and predict some possible meanings.

On the other hand, it is mistaken to think that there is a little problem in deciding of a given sentence whether a sentence is ambiguous or not. Take for example, the word “good” in isolation. One might think that it is not ambiguous word because the meaning is virtually clear. But when it is put into a sentence such as *She has good legs*. Some interpretations will come up with the word “good”. The word “good” might have a number of meanings. This can mean that she has healthy legs, or it can mean she has beautiful legs, or it can mean that she has legs that function well, for example in sport as an athlete. Thus, the word *good* has a number of different interpretations when it is used in a sentence.

Other example of ambiguity can be seen in the sentence *We saw her duck*. This sentence yields different interpretations. In one hand, the phrase “her duck” can be interpreted differently. The problem is that the word “her” itself can function as either possessive pronoun or objective pronoun. If it functions as possessive pronoun, *her duck* is similar to other forms such as *my duck*, *his duck*, etc. so that the word “duck” contains entity of animal, because the word “duck” in this context functions as a noun.

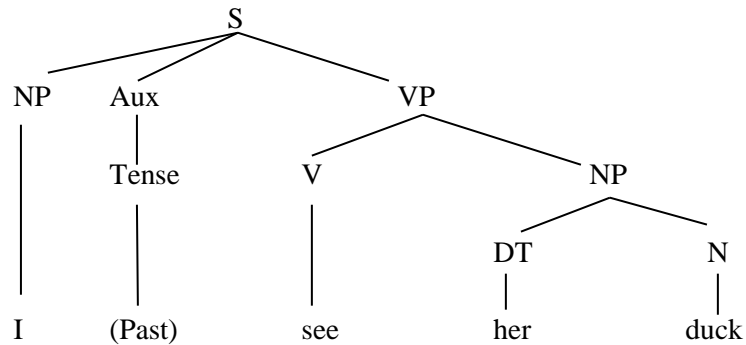

Figure 5. The structure of “I saw her duck” 1

The structure of this sentence can be seen in Figure 5. If *her* functions as an objective pronoun (indirect object), the word *duck* functions as a verb. Again, if it is so, the verb *duck* might have a number of meanings such as, (1) move quickly down or to one side (to avoid being seen or hit); (2) go quickly under water for a short time (see Figure 6). However, the sentence is not ambiguous if the pronoun is other than *her*, for example, *I saw his duck*, *I saw your duck*, or *I saw him duck*, *I saw them duck*, etc. That means that the ambiguous word is mainly on the pronoun “her”. Thus the ambiguity of the sentence is rather clear. The sentence has many meanings depending on where it is seen. There must be other similar ambiguous forms that can be found.

Furthermore, Kempson (1984: 124-125) distinguishes ambiguity from vagueness and classifies this into four main types of vagueness. These four

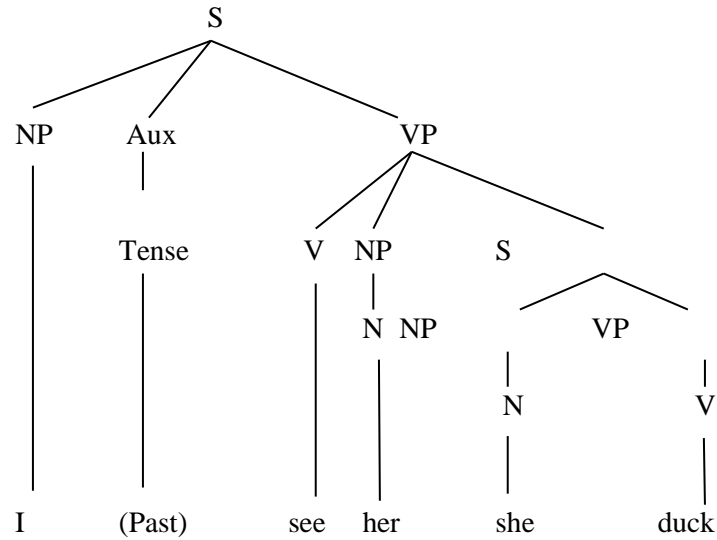

Figure 6 The structure of “I saw her duck”

2 classifications are discussed below. The first is referential vagueness, where the meaning of lexical item is in principle clear enough but it may be hard to decide whether or not the item can be applied to a certain object. Take for example the lexical items *city* and *town*.

These two words have something in common, that is simply a place where collection of people live, made up a certain number of houses. We agree that the meaning of each word needs a specification; we have difficulty to decide if some places are called city or town. Perhaps one place in a certain country is called a city but for other people from different country it would be called town, etc.

The second type is indeterminacy of meaning, where the meaning itself of an item seems indeterminate, where the interpretation seems quite intangible. The most common example of this is the possessive construction: *John's book*, *John's train*, *John's school*. John's book can describe as the book which is owned by John, the book which is written by John, or the book that John has been reading. John's train can imply that the train that John took, the train he normally goes on, the train he is going to catch or to drive, etc. John's school can be interpreted as the school the he went to, the school that he is studying in, the school that he teaches in or even the school that he founded, etc. Thus, the meaning of this kind is so indeterminate.

The third type is lack of specification in the meaning of an item, where the meaning though in principle quite clear is very general. The simple example of this lack of specification is the word *neighbor*. This word is unspecified for sex, race, or age, etc. Other examples are verbs like *go*, *do*. These words have a clearly specifiable meaning, and yet cover a wide variety of

meanings or actions. The next verb is “do” as in *I’ve done the sitting-room*. This sentence can describe that he/she cleans the sitting-room, paints it, empties it, etc., depending whether the speaker (writer) is cleaner, painter, a furniture remover, etc. Other similar expressions are to do some object - *to do the engine, to do the dishes*, etc., - means to carry out some actions involving the objects; but the actions are quite unspecified.

The fourth type is disjunction in the specification of the meaning of an item, where the meaning involves an *either or* statement of different interpretation possibilities. The disjunction within a single lexical item leads to a prediction that more than one of disjunction can be interpreted, and then such interpretations should be possible simultaneously. The example of this item is the word *run*. Consider the word run in the following sentences.

- (1) He *ran* onto the field.
- (2) He *ran* the race for Hampshire.
- (3) The ball *ran* onto the field.
- (4) The car is *running* well.
- (5) The road *runs* from Krawang to Bekasi.
- (6) He *runs* the motorshow.

The verb *run* used in above sentences has many meanings. But the most common meaning for this verb is that in sentence (1). The learners usually have difficulty when the intended meaning is other than this one.

In addition to different interpretation, the opposite case can also occur. We often find that different types of sentences can actually be used for the same purpose. In other words, the opportunity for variety arises from the relationship between grammar and discourse. For example, the unmarked form of a directive may be imperative, “Shut the door”, but there are many marked versions, using interrogative, declarative and moodless structure (Coulthard, 1989: 129):

Can you shut the door?
Would you mind shutting the door?
I wonder if you could shut the door?
The door is still open
The door.

This illustration also shows the relationship between form and meaning, surface structure and deep structure. What often happens is that a sentence is read at the surface level (what is printed). Harris and Smith (1986) assert that readers understand the ideas communicated by the author by engaging in a series of transformations that take them to deep structure. For example, the following three sentences have different surface structures, but they actually have the same meaning

- (1) John drew a red cat
- (2) John drew a cat red
- (3) John drew a cat that was red

Thus, in order to gain the meaning from the printed page, the readers must be able to recover deep structure.

We have discussed the types of vagueness in theory of meaning. The examples in the four types of vagueness are still limited. There must other similar examples that belong to these four types. This part is to show that a reader should be able to identify the type of sentences that contain vagueness and decide to take the intended meaning.

REFERENCES

- Bloomfield, L. (1933). *Language*. New York: Holt, Rinehart, and Winston.
- Bolinger, D. (1975). *Aspect of Language*. New York: Harcourt Brace Jovanovich.
- Brown, G. and Yule, G. (1985). *Discourse analysis*. New York: Cambridge University Press.
- Chomsky, N. (1965). *Aspects of the theory of syntax*. Cambridge Mass.: M.I.T. Press.
- Coulthard, M. (1989). *An introduction to discourse analysis*. New York: Longman.
- Harris, L.A. and Smith, C.B. (1986.) *Reading Instruction: Diagnostic teaching in the classroom*. New York: Macmillan.
- Kempson, R.H. (1984). *Semantic theory*. New York; Cambridge University Press.
- Littlewood, W. (1989). *Foreign and second language learning: Language acquisition research and its implications for the classroom*. New York: Cambridge University Press.
- Nation, I.S.P. (2005). Teaching and learning vocabulary. In Eli Hinkel (Ed.) *Handbook of Research in Second Language Teaching and Learning*. New Jersey: Lawrence Erlbaum Associate.
- Van Dijk, T.A. (1977). *Text and context: Explorations in the semantics and pragmatics of discourse*. London: Longman.
- Wardough, R. (1975). Linguistics and reading. In C.B. Smith and R. Wardough, *Teacher's Resource Book*. New York: Macmillan.

ENHANCING SPEAKING FLUENCY THROUGH 4/3/2 TECHNIQUE OF EFL STUDENTS

Hery Yufrizal

University of Lampung, Indonesia
heryyufrizal@gmail.com

ABSTRACT

The main objective of this article is to explore the application of 4/3/2 technique in enhancing learners' speaking fluency. The research was conducted at a language school in Indonesia. The subjects of the study were 20 first year students at the University of Lampung. The students were separated into two teams: the deliverer and the receiver teams. The deliverer team was given the opportunity to speak for three speaking turns: four minutes, three minutes and two minutes. Then, the teams change roles: the speakers become listeners, the listeners become speakers. The topics of the talks were determined by the group prior to the application of the activities. The results showed that students improve their speaking accuracy and fluency during three speaking turns.

Keywords: *fluency, accuracy, talks, 4/3/2 technique*

I. INTRODUCTION

One of the techniques that can be used to improve students' speaking ability is 4/3/2 technique. According to Zhou (2006:19), this technique improves students' speaking English and increases the students' accuracy in speaking English. This technique also encourages students to use English without being worried of making any mistakes.

The 4/3/2 technique was created by Maurice (1983) to improve students' fluency for communication. The 4/3/2 technique means repetition of the talk content to different listeners without having to worry of what has been said. The characteristics of this technique is having a speaker(s) and the same content of the speech, but different listener and the decreasing of taking time. (Zhang 2002: 420).

The 4/3/2 technique gives opportunity to students to express their ideas to three different listeners for four minutes, three minutes, and two minutes with the same topic but different listeners. This will enable students to express their ideas without being worried of making any mistakes.

The rapid progress in information technology has been far beyond every one expected. Students are ornamented with the presence of handphones on multi media basis. There is a fact that almost all students possess handphones both for entertainment purposes and for other social media purposes. The use of multi media cellular phone is indispensable from the objective of teaching and learning English, i.e. to enable the students to communicate orally and in written.

II. THEORETICAL FRAMEWORK

Maurice (1983) created the 4/3/2 technique to improve the oral language fluency. The technique has the meaning of repetition of the content of the talk by the speaker to different listeners in terms of minute to talk. The characteristics of this technique is the same speaker and the same content of speech, different listener and the decreasing time of speech. (Zhang 2002, Arab, 2006).

4/3/2 technique provides opportunities for students to deliver their thoughts to the listener with a duration of four minutes, three minutes, and two minutes with the same topic but different counterparts. This giving the opportunity to speak in three different length of speech will enable students to express what they want to say without being afraid of making mistakes.

There are some steps that must be followed in the implementation of 4/3/2 technique

a. Topic determination

Topic determination is undertaken after the students have understood what they are supposed to do. The topic chosen can be single topic that should be selected by all students or it can be some alternative adjusted to the curriculum so that a topic selected by one student can be different from other. The topic selected is adjusted to students' ability and interest. Some common topics selected are 'me and my family', 'the most interesting experience I ever have', 'my hobbies', 'TV Program, etc.

b. Drafting the talk

The second step in accomplishing 4/3/2 is drafting the talk. After the students decided the topic they choose, the students are asked to arrange draft (not a complete composition) about what they are supposed to deliver. The students are asked to compose an outline to deliver a speech for four minutes. The time allocated for drafting the speech is 10 to 15 minutes.

c. The division of participants into speakers and listeners

After all students finished drafting for talk, the students are divided into pairs.

III. METHODS

This study is a quasi experimental in nature. It has an experimental group, i.e. without a control group. It seeks to answer a research question whether the activities done by the sample produce the same amount of phenomenon it seeks to answer. The subjects of the research were the first year students of English Department, the University of Lampung Indonesia. It seeks to answer a research question whether or not the subjects of the research produce fluency and accuracy when implementing the 4/3/2 technique.

The research procedures are the students are divided into speakers and listeners. The speakers are assigned to talk to listeners in 4/3/and 2 minutes talking with the topics chosen by the speakers. Students then change roles, speakers became listeners, listeners become speakers who would speak for four, minutes, three minutes and two minutes. There are three alternative topics that students can choose to be delivered in their

speeches. The alternative topics are: Me and my hobbies, why I choose English as my major, and The most exciting experience I've ever experienced.

IV. RESULTS AND DISCUSSION

Language elements produced

Language element produced are divided into two parts: fluency and accuracy. The results are as follows:

Fluency

i. words per minute

Table 1 illustrate the number of words per minute produced by students for the first turn (four minute talk), the second turn talk (three minutes) and the third turn talk (two minutes)

Table 1 Number of words produced in three talks

	N	Minimum	Maximum	Mean	Std. Deviation
wpm4	20	23,00	121,25	71,6750	26,90797
wpm3	20	26,00	131,00	75,4901	27,14023
wpm2	20	28,00	119,00	81,7500	27,45882
Valid N (listwise)	20				

Table 1 shows that the number of words produced by students per minute in the first turn talking (four minute) talk is 71,67. On the second turn the average number of words per minute produced was 75,49, and the third talk time was 81,75. Thus, it can concluded that there is a constant increase in the number of words produced in each talk turn

ii. The number of pauses

Tabel 2 The number of pauses) in three talk turns

	N	Minimum	Maximum	Mean	Std. Deviation
pauses4	20	3,00	47,00	14,5500	11,39471
pauses3	20	1,00	17,00	7,4500	4,78457
pauses2	20	,00	15,00	5,4000	4,22275
Valid N (listwise)	20				

From the number of pauses, in the first turn the average number of turn taken by the student was 11,39. 14,78 pauses were produced in the second turn, while in the third turn students produced 4,22 pauses. Therefore, it can be concluded that that there was a decreasing number of pauses produced in the first, second, and third turns of talk.

iii Number of hesitations

Tabel 3 The number of hesitations produced in three talking turns

	N	Minimum	Maximum	Mean	Std. Deviation
hesitation4	20	1,00	20,00	5,5500	4,61662

hesitation3	20	,00	12,00	4,0500	3,28433
hesitation2	20	,00	10,00	2,7000	2,75490
Valid N (listwise)	20				

The average number of hesitations resulted from the first talking session was 5.55 hesitations in the first. It decreases into 4.22 hesitations in the second turn and into 2.70 in the third session of the tasks. Therefore, it can be inferred that there is a constant decreasing number of hesitations produced by subjects during the first, second, and third turns of students' talk.

iv. The number of false-starting

Tabel 4 The number of false starting

	N	Minimum	Maximum	Mean	Std. Deviation
false4	20	,00	7,00	1,8000	1,60918
false3	20	,00	7,00	1,8000	1,82382
false2	20	,00	4,00	,8500	1,03999
Valid N (listwise)	20				

The average number of false starting resulted from the first talking session was 1.8 false starting in the first. It remains 1.8 false startings in the second turn and into .88 in the third session of the tasks. Therefore, it can be inferred that there is a constant decreasing number of false startings produced by subjects during the first, second, and third turns of students' talk.

v. The number of L1 use

Tabel 4. 5 The number of L1 use

	N	Minimum	Maximum	Mean	Std. Deviation
L14	20	,00	9,00	1,8000	2,54641
L13	20	,00	5,00	,9500	1,27630
L12	20	,00	5,00	,7000	1,49032
Valid N (listwise)	20				

The average number of L1 uses resulted from the first talking session was 2.54 L1 uses in the first. It decreases into 1.27 L1 uses in the second turn and into 1.49 in the third session of the tasks. Therefore, it can be inferred that there is a constant decreasing number of L1 uses produced by subjects during the first, second, and third turns of students' talk.

Speaking Accuracy

Speaking accuracy is defined in terms of the number of errors committed by students in each talking turn. The following is the number of accuracy produced by students during the sessions.

Self repair on single word

Student revises a mistake in producing one word. Misal: My name is Wulan, I was born in...on April 1997 (pada pembicaraan pertama)

For example: My name is Wulan I was born on April 1997.

Self repair on clause

Student revise the error commiterd in the first talk

4 minute talk: What I dream ...eee...before...uuuh...what I dream in the future first...uhhm in the first, I am going to continue...

3 minute talk: I choose uhh the two option about what I dream in the future... first...uhh..in uhhh rational

2 minute talk: I choose the second option what I dream in future...as for the...uhhh...the.... for my rationale dream.

Self repair on sentence

4 minute talk: and my mother, my mother's name is Mutia. She was born in Medan on... September 8th 1964. And then now he works as a house wife... you know house wife. He...she doesn't work uhhh anywhere.

3 minute : "And.then... my mother, my mother's name is Mutia. She works..uhh she was born in Medan, on September 8th 1964. And then uhhh she is a house wife, you know that she doesn't work.

2 minute talk:: And my mother's name ia Mutia. She was born in Medan, on September 8th 1964, and now she has been 52 years old

According to research done by Movahed and Karia (2014) the 4/3/2 technique has three main advantages: improving the speaking flency, increasing grammatical accuracy, and intensifying control over the content of the talks.

4/3/2 technique increase fluency of talk

There are 8 cases that show 4/3/2 technique was successful to improve the speed of talk. The first case study showed that there are improvements of language production by students in in the first turn (four minute talk) to the second turn of talk.

The students talk in the average speed of 86 words per minute on the first turn talking. It then increased to 100 words per minute in the second turn, then the speech increased to 122 word per minute in the third turn of the talk.

The research also shows that there was an increase in the number of words produced by students in the first four minute turn. Students produced 71.67 words per minute in first turn talking. It then increased to 75.words per minute in the second turn. While in the third turn talking students produced 81.75 words per minute in the third talking turn. Nation (1989) stated that 4/3/2 decreases the number of hesitation from 1 percent to 67 percent of hesitation in the first, second and the third talking turns.

4/3/2 technique strengthen grammatical power

This technique requires the participant to talk about the same topic to different listeners. Of course, there would be some repetitions made by the speakers in the first, second, and third turns because the topic is similar without new information delivered. Nation (1989) stressed that from 8 studies, 4 of which showed the same errors were found in each turn. This shows that there are some accuracy improvements under two conditions firstly, repetitions improve students' self reliance. Secondly, according to Nation (1989) the technique has the local influence in the talk that it enables students to monitor their performance.

4/3/2 technique increases control over content

When we talk, we often use unnecessary words or phrases. By giving time limitation to talk, the speaker tries to deliver the intention of the talk directly without using unnecessary ornaments. This will increase the complexity and avoid ambiguity in the talk. From the data obtained, students in this study are able to cut off 144 unnecessary words in the third turn taking. This confirms the research by Nation (1989), Movahed and Karia (2014) that by limiting the talk, the students are 'forced' to transfer information concisely and efficiently.

4/3/2 technique improve students motivation to talk in English

One of the characteristics of Indonesian students learning English is their lack of confidence in using English for communication. (Alissyahbana, 1989). Through 4/3/2 technique students are motivated to talk in English because they have to talk to three different listeners. They are forced to speak more and faster due to the limitation of time given.

V. CONCLUSIONS AND SUGGESTIONS

Based on the results of the analysis, some conclusions can be drawn. The 4/3/2 technique improve the speaking fluency, grammatical accuracy and control the content of the talk. The result of study showed that the number of words produced by students increased constantly during the first, the second and the third turn. Additionally, the data showed the number of pauses, the number of hesitations, the number of false startings and repetitions are kept on decreasing from the first, the second, and the third turn taking.

Additional conclusions that can be drawn from the study are:

- a. The 4/3/2 technique provide opportunities for students to self reflection over their speaking English ability.
- b. The 4/3/2 technique provides opportunities for students to train transcribing their conversation.
- c. The 4/3/2 technique gives the opportunity for students do make coding over language aspects.
- d. The 4/3/2 technique provides opportunities to do peer review and peer correction.

Considering the fact that the 4/3/2 technique can improve students' speaking accuracy and fluency, it is suggested that the technique be applied and developed at all levels of education and learning ability. Considering that the massive use of cellular phone for

learning language, it will be useful for lecturers and students to make use of this tool to improve language learning massively.

REFERENCES

- Alisyahbana, ST. (1990). *The teaching of english in Indonesia*. In J.M. Britton, R.E Shaffer, and K.Watson(Eds.). *Teaching and Learning English Worldwide*. Cleveland. Multilingual Matters, Ltd.
- Arevart, S. & I.S.P Nation. (1991). *Fluency improvement in a second language*. RELC Journal 1: 84- 95.
- Arab, Oudid. (2016). The Effect of the 4/3/2 technique on students' speaking fluency The case of first year LMD students, Frères Mentouri University, Constantine. *Revue EXPRESSIONS n°2. Juillet*
- Brumfit. C.J. (1994). *The practice of communicatve teaching*. Pergamon Press
- Brumfit. C.J. (2000). *Individual freedom in language teaching*. Oxord, Oxford University Press.
- Ellis, R. (1994). *The study of second language acquisition*. Oxford: Oxford University Press
- Maurice K. (1983). The fluency workshop TESOL Newsletter. !7 (4) 29.
- Foster, P. & P. Skehan. (1996). *The influence of planning and task type on second language performance*. *Studies in Second Language Acquisition* 18 : 299 – 32.
- Higgs, T.V. and Clifford, T. (1992). The push toward communication. In T.V Higgs (Ed.) *Curriculum, Competence, and the Foreign Language Teacher*. Pp.57-136. Lincolnwood, IL. National Textbook, Co
- Long, M.C. (2007). *Problems in SLA* Mahwah, NJ Lawrence Erlbaum Associations
- Nation, Paul. (1990). *Improving speaking fluency*. Pergamon Press. www.victoria.ac.nz/lals/staff/.../paul-nation/1989-Fluency.pdf. {Online}. Available. accessed on December 20, 2011
- Nation, P. (1989). *Improving speaking fluency*. *System*, 17 (3), 377-384.
- Nation, I. Newton, J. (2009). *Teaching ESL/EFL listening and speaking*. New York: Cambridge University Press.
- Nunan, D. (1999). *Second language teacher education*. Cambridge: Cambridge University Press.
- Nunan, D. (1993). *Second language teaching and learning*. Cambrisge: Newbury House.
- Sajavaara. (1987). *Second language acquisition in a study abroad context*. John Benjamin Publishing Company.
- Schmidt. R. *Studies in second language acquisition*. Cambridge. Cambridge University Press.
- Skehan, P. (1996). *A framework for the implementation of task- based instruction*. *Applied Linguistics* 17/1: 38- 62.
- Skehan, P. P. Foster. (1999). *The influence of task structure and processing conditions on narrative retellings*. *Language Learning* 49/1: 93-120
- Stern. H.H. *Issues and options in language teaching*. Oxford. Oxford University Press.
- Stren M. (1994). *An introduction to spoken interaction*. London: Longman Group Limited.
- Ur, Penny. (1996). *A couse in language teaching*. Cambridge University Press
- YANG, Y.I.J. (2014a). The development of speaking fluency: the 4/3/2 technique for the efl learners in china. *International Journal of Research Studies in Language Learning*, 3(4), 55-70.

- YANG, Y.I.J. (2014b). The implementation of speaking fluency in communicative language teaching: an observation of adopting the 4/3/2 activity in high schools in china. *International Journal of English Language Education*, 2(1), 193-214.
- Zhang, Wenzhong. (2002). *The development of l2 oral fluency in efl classroom setting*. Changsha: Hunan Education Press.
- Zhou , Aijie. (2002). A study of the effects of the 4/32 technique on the fluency improvement in oral English. *Journal of Guangdong Polytechnic Normal University* 2: 102- 105.
- Zhou Aijie. (2006). A Further Study of the Effects of the 4/3/2 Technique on Spoken English Production. *CELEA Journal* 65

About the Author

Hery Yufrizal is currently a senior lecturer at the department of language and art education, FKIP Universitas Lampung. He teaches Second Language Acquisition, Semantics, Pragmatics and Speaking. He got his PhD in Applied Linguistics from La Trobe University, Melbourne, Australia in 2001. His research interests include: classroom interaction, teachers' development, and discourse analysis.

EMPLOYING SELF-ASSESSMENT TECHNIQUE TO PROMOTE STUDENT'S WRITING ABILITY IN COMPOSING CAUSE-EFFECT ESSAY AT UNIVERSITAS MUHAMMADIYAH GORONTALO

Indah Wardaty Saud¹, Yulan Puluhulawa², Dahlia Husain³

Universitas Muhammadiyah Gorontalo

Jln. Prof Dr. H. Mansoer Pateda, Pentadio Timur, Kec. Telaga Biru Kab. Gorontalo

indahsaud@umgo.ac.id¹

ABSTRACT

This present study aimed to improve students' writing ability through self-assessment technique. The researcher used an action research method with two cycles. Each of cycle compromised four procedures namely: planning, implementation, observation, and reflection. The data was collected by observation and test. The researcher used an observation sheet towards students and teacher's activities during teaching and learning process. In addition, the researcher used test to assess students' achievement in writing. The subject of this study were 25 students of English Literature in Universitas Muhammadiyah Gorontalo who enrolled Essay Writing Subject in academic year of 2016/2017. The result showed that students' writing ability improved significantly through self-assessment technique. The students had improvement in five aspects such as content, organization, vocabulary, language use and mechanics. The students' writing average score achieved 86,2. The students' response towards the technique was good, that the students agree of the benefits they obtained through self-assessment technique.

Keywords: *writing, cause-effect essay, self-assessment*

I. INTRODUCTION

Writing is one of four skills that students need to proficient in learning English as a foreign language. Students in an English department have to train themselves to be familiar with complex processes in composing an essay such as the process of gathering ideas, vocabulary enrichment, and grammatical rules in writing. These processes engage perpetually with four important aspects in writing that are content, organization, vocabulary, language use, and mechanism, that need to be mastered by the students at the same time. This is the reason why writing is considered as the most difficult skill for the students. Richard and Renandya (2002) agreed and emphasized that writing is the most difficult skill for L2 learners and the difficult is not only in generating ideas but also transferring ideas into a text.

In English Department of cultural science faculty in Universitas Muhammadiyah Gorontalo, the researcher found that generally, the students who were in writing class had lack of English vocabulary and less of ability in composing sentences using the correct grammar. As a result, the lecturer needed to explain how to compose the correct sentences in English, first

before she came to the topic/material based on course outline. It was considered as a time consuming activity, yet the lecturer thought it was the best way because she could not ask the students to compose an essay before they known to write sentences with the correct grammar.

In “Basic Writing” course, the students got low achievement in writing task. Most of them got below 70. Only eleven out of twenty five students had score above 70, and the rest thirteen students got score in range of 60-67. This result probably happened because the students’ lack of grammar mastery and the students’ lack of time in evaluating their own writing during they wrote an essay. This phenomenon attracted the researcher to find a solution in minimizing lecturer’s overwhelming task in evaluating students’ writing individually, to promote students’ writing ability in composing an essay, and to provide appropriate time for students to evaluate their work. Finally, self assessment was employed in the next writing course that was “Essay Writing” course.

Self Assessment is believed as a suitable technique to solve problems occur in writing an essay. Through this technique, the students develop their confidence and independence to analyze and evaluate their own writing, (Siew, 2007). In addition, Mariana (2017) elucidates that students train their critical thinking, observing, and finding out their own mistakes in writing and try to compose a better essay in the next opportunity. After all, if it is applied effectively, the students’ writing ability can develop and the teaching and learning process can be meaningful for both students and lecturer/teacher.

It is in line with Alderson’s perspective (2000) about self-assessment. He defines self-assessment is increasingly seen as a useful source of information on learner abilities and processes. Similarly, Student Self-assessment leads the instruction in learning toward helping individuals better understand themselves so that they can make more intelligent decision (Gronlund & Waugh, 2009). As stated by Cohen, Manion and Morrison (2004), that it can build students’ self confidence because it lets them to give more accurate information about their progress. At the same time, they are motivated to set their own targets and refer back to these at a given point in time in order to assess how successfully they have met those targets.

There are some reasons for choosing Self Assessment as the appropriate technique to overcome problems in writing class. First, the abundant number of studies in the field has indicated that Self Assessment is crucially effective and significant in developing the various language skills and learning strategies and in raising the awareness and motivation necessary for language learning (Mazloomi & Khabiri, 2018). Second, it can identify the gap between the learners’ knowledge and that of their teachers’ criteria for their writing assessment. It can also help them develop their own criteria for success in their writing classes. Third, Self-assessment provides information to be used as feedback to modify the teaching and learning activities in which the students are engaged. It also will ultimately lead to increase productivity and autonomy, higher motivation, less frustration and higher retention rates among learners, (Rivers, 2001)

II. METHODS

This study used mix method, both qualitative and quantitative since it aims to describe the employment of self-assessment technique in teaching writing. This study is conducted based on the problems occur in the field which is analyzed with the supporting theories. This study is an action research with four procedures namely planning, implementation, observation, and reflection. The reflection stage aims to fix several weaknesses for the next cycle. The subjects of this study were 25 students of English Literature in Universitas Muhammadiyah Gorontalo who enrolled Essay Writing Subject in academic year of 2016/2017. The researcher acted as a collaborative lecturer in teaching writing to the subjects.

The researcher prepares the strategy and the activity, the appropriate lesson plan, and the teaching media and material, the students' worksheet, the instrument of data collection, and set of criteria of success. The researcher also provides two follow up activities into two cycles. These two follow up activities are aimed to reduce the ignorance of students doing self assessment. These two activities are portfolios and publishing on the Facebook. The researcher emphasizes the students' performance in writing on five aspects such as content, organization, vocabulary, language use and mechanics. The researcher also set the criteria of success as in table 1.

Table 1. Criteria of success

The criteria of Success	
The Process	The Product
All students in "essay writing" class are motivated during the action.	The students are expected to achieve the average score: 85 as the passing grade

In collecting the data in this study, the researcher uses several instruments. The test; is students' writing in composing cause-effect essay, observation sheet, and questionnaire. Observation sheet is used to obtain the data about the implementation of self assessment in teaching writing, its benefits in particular. Meanwhile, the questionnaire is used to find out the students' opinion and responds towards the teaching and learning process with self assessment assistance.

After introducing and explaining self assessment usage in writing, the researcher analyzes the result of its implementation. In this case, reflection is done to investigate whether or not the students achieve the criteria of success.

III. RESULTS AND DISCUSSION

This study is conducted into two cycles. In cycle 1, the researcher and lecturer introduce self assessment as new instrument in writing class and it aims to help the students in composing their essay. Then, they are asked to write a cause-effect essay and choose the topic of essay by themselves. The topics are various based on students' interest but the type of those essays is cause-effect essay. This cycle runs for 4 meetings including the steps of writing that are prewriting, writing, revising, editing, and publishing. In this cycle the students need to publish their writing in form of portfolio file. Based on observation result of cycle 1, most of the students are confused in using self assessment sheet and they are reluctant to express themselves at the beginning. The lower students were not comfortable and did not like the idea of revealing their failure in writing an essay. As a consequence, the researcher and lecturer spent some time with those students to explain them about aims of the technique which is to help them in order to know the mistakes that they have done in their writing and they could revise it immediately. It also helps the lecturer to determine the students' problems and to know about students' strengths in order to handle and reinforce them properly. Another weakness in this cycle is that in post-writing activity. Most of the students are not interested and not enthusiast in the way of keeping their writing by themselves in form of portfolio file. They wanted their writing published online, hence; everybody could read their writing. The students' writing score do not achieve minimum score which is set as the criteria of success, with average score 72,4. Sixteen students got below 75 and the rest got above 75. Therefore, the researcher plans cycle two with several changes to achieve the criteria of success.

In cycle 2, the students are asked to write again a cause-effect essay and are asked to publish it online in Facebook. But, before they publish it, the lecturer emphasizes that they have to evaluate their writing carefully by using self assessment since it will be seen by everyone in their FB. In that way, the students are excited to write the essay better than in cycle 1. In this cycle, the students have opportunity to discuss the draft of their essay with the lecturer and their friends. Feedback for lecturer and friends help the student develop their paragraphs in essay. After that, the students observe, analyze, and evaluate their writing with assistance of self assessment. In this cycle, students are more confident and honest to express their progress of essay on self-assessment sheet. Based on their evaluation on self-assessment sheet, they revise the essay, write the revised one again, and publish it on FB. They are aware that their writing improved when they use self assessment well because they found their mistakes and weakness through self assessment sheet. They understand and evaluate the structure of an essay that are introduction, body paragraphs, and concluding paragraphs. In addition, they understand how to develop introductory paragraph by using anecdote, general to specific and historical style. They are also able to write a thesis statement with or without predictors. In short, they are improve in participation in class and writing skill with focus on content, organization, vocabulary, language use and mechanics. This cycle spent also 4 meetings. The result of this cycle was that 19 students got 80-95. Only 2 students got below

75 and the rest 3 got 75. Therefore, the students average score was 86,2 which pass the criteria set before, that is 85.

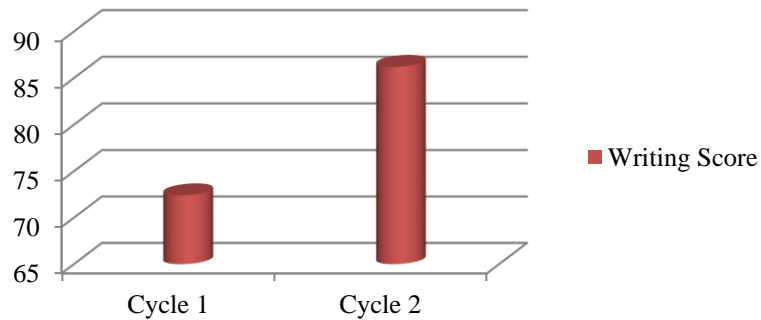

The questionnaire shows that the students' response towards self assessment is positive. All students said that self assessment help them to fix their first draft, to find out their mistakes particularly in grammar, vocabulary, and punctuation, guide them to analyze carefully every part of essay. By using self assessment they feel more confident to write and to publish their writing online on their FB because they believe the mistakes have been revised before. According to Cohen, Manion and Morrison (2004), that Self-Assessment can build students' self confidence because it lets them to give more accurate information about their progress. At the same time, they are motivated to set their own targets and refer back to these at a given point in time in order to assess how successfully they have met those targets. In line with Brown and Harris (2014) who argue that students' self-assessment is an important aspect of and contributor to greater self-regulation of learning. Thus, the students in this study applied self assessment effectively because they improve their participation during teaching and learning, their confidence, their awareness to learn regularly, and their writing on cause and effect essay.

IV. CONCLUSION AND SUGGESTION

To improve students writing skill, the lecturer has to employ the appropriate strategy. The lecturer needs to explain the students the importance of composing a good essay. To create a good essay absolutely needs time and several steps such as prewriting, editing, revising, and publishing. In editing and revising step, self assessment is appropriate instrument to measure the progress of their writing. Besides, the lecturer also needs to act as a facilitator who guide and explain them the benefits of evaluate their writing by using self assessment before they publish it. Furthermore, the lecturer should give opportunity for students to discuss their essay with lecturer and friend to get fruitful feedback.

REFERENCES

- Alderson, Charles. (2000). *Assessing reading*. United Kingdom: Cambridge University Press.
- Brown & Harris. (2014). The future of self-assessment in classroom practice: reframing self-assessment as a core competency. *Frontline Learning Research*. Vol 03 Page 22-30
- Cohen, Louis., Lawrence Manion., Keith Morrison. (2004). *A guide to teaching practice*. New York: Routledge
- Gronlund, Norman E., C. Keith Waugh. (2009). *Assessment of student achievement*. USA: Pearson Education.
- Mariana. (2017). Peningkatan keterampilan menulis paragraf melalui penerapan kegiatan menulis jurnal dan pemanfaatannya pada siswa kelas vii mts negeri Kota Tebing Tinggi. *Sej Volume 7 No.1 Juni page 96-104*
- Mazloomi & Khabiri. (2018). The impact of self-assessment on language learners' writing skill. *Innovations in Education and Teaching International*. Vol. 55, No. 1, 91–100
- Richard, J.C & Renandya, W.A. (2002). *Methodology in language teaching*. Cambridge: Cambridge University Press.
- Rivers, W. P. (2001). Autonomy at all costs: An ethnography of metacognitive self-assessment and self-management among experienced language learners. *The Modern Language Journal*, 85, 279–290
- Siew, K.T. (2007). *How does peer editing improve students' quality of writing*, (online), (<http://conference.nie.edu.sg/paper/.../ab00279.pdf>), downloaded on February 2nd, 2012

TRANSLATION AS A LEARNING STRATEGY BY EFL LEARNERS IN A PUBLIC UNIVERSITY IN INDONESIA

Gede Eka Putrawan

Department of English Education, University of Lampung, Indonesia

gputrawan08@fkip.unila.ac.id

ABSTRACT

In recent years, there have been many papers describing the importance of translation in EFL teaching and learning. Although translation has been very controversial in EFL teaching and learning for decades, some experts advocate the inclusion of translation in EFL teaching and learning, but some others do not. Thus, this study was aimed at investigating the use of translation and in what EFL aspects and skills translation is used as a learning strategy by EFL learners in a public university in Indonesia. The data in this study were collected through a survey questionnaire, the *Inventory for Translation as a Learning Strategy (ITLS)*. A total of 68 first year university students majoring in English Education were selected to take part in this study. They were considered as intermediate EFL learners since they have been studying English since they were in elementary school. The results show that the first-year university students majoring in English Education still make frequent use of translation in their EFL learning. They use translation to improve their English skills in terms of reading, writing, listening and speaking, English vocabulary, phrases, grammar, to clarify the similarities and differences between Indonesian and English, to interact with other, and as their learning aids which include the use of English – Indonesian dictionary, Indonesian – English dictionary, and electronic translation machine.

Keywords: *translation, learning strategy, English, EFL*

I. INTRODUCTION

In recent years, there have been many papers describing the importance of translation in English as a foreign language (EFL) teaching and learning. Although, translation has been very controversial in EFL teaching and learning for decades, some experts advocate the inclusion of translation in EFL teaching and learning, but some others do not. In other words, some of them advocate the use of monolingual approach, while some others propose the use of translation as an aid to EFL teaching and learning.

The use of translation as a teaching tool in language classrooms is associated with the so-called ‘Grammar Translation Method’. This method views that translation is

crucial for foreign language teaching and learning, however, it is now said that this method is no longer used in foreign language teaching and learning. Foreign language teachers at the present time believed and are suggested to apply the most famous teaching approach, that is Communicative Language Teaching (CLT). Through CLT, learners' native language is no longer used in the classroom and neither is translation. In addition, learners are also required to think in the language being learned to achieve native-like control of the language without the use of translation. Simply put, translation should be ignored and avoided in EFL teaching and learning since it is not a useful tool for acquiring a foreign language.

Some arguments and assumptions against the use of translation in language teaching and learning are proposed by several scholars. They state that translation is not a communicative act and has nothing to do in a communicative approach with language teaching (Duff, 1989:6). Translation is also said as an artificial exercise that focuses on reading and writing, thus students do not practice oral skills (Zabalbeascoa, 1990:76). In addition, translation tasks are said to be useless and do not resemble real world practice (Carreres, 2006), have nothing to do with the way in which a mother tongue is learnt that it does not promote a natural foreign language learning (Sankey, 1991:418), and it provides a false belief that there is a perfect one-to-one relationship between the native language and the foreign language (Malmkjaer, 2010:186). Other scholars also argue that translation causes students to receive insufficient foreign language input and makes learners view the foreign language through their native language in which this can cause interference between the two languages involved (Pan and Pan, 2012:4). Translation can be a boring and non-stimulating task (Duff, 1989) and can be frustrating and de-motivating for students (Carreres, 2006). Translation is also said to be not suitable for all learners since it can only work well with those interested in literature or with those who have already acquired a significant level of proficiency in the foreign language (Mogahed, 2011) (as cited in Guerra, 2014). Translation is not the aim of language learning, it is the aim of translator training and both are independent fields of study (Vermes, 2010).

However, a large body of research findings concerning the importance of translation in EFL teaching and learning has been reported. It means that translation is believed to play an important role in EFL teaching and learning. It is reported that Iranian students employ translation as a learning strategy to help them learn English during the process of language learning (Karimian & Talebinejad, 2013). This strategy should not be ignored because it helps new EFL learners learn English, however, as they reach higher level of EFL proficiency, they are required to think directly in English to improve their overall English abilities (Tan, 2015). Although it is believed that a lot of foreign language teachers no longer make use of translation in their classrooms, however, translation actually still exists in EFL instructions in Indonesia.

If we further see from foreign language learners' perspective, translation is still widely used to help them comprehend the foreign language being learned more easily (Aktekin & Gliniecki, 2015; Al-Musawi, 2014; Dagilienè, 2012; Karimian & Talebinejad, 2013; Liao, 2006; Mutlu, Bayram, & Demirbuken, 2015; Tan, 2015; Ying, Hoon, Halim, & Majtanova, 2018).

Therefore, this study was urgent to conduct to scientifically find out if translation learning strategy still exists among EFL learners in a public university in Lampung Province, Indonesia, as reported by other studies. Therefore, the research question of the present study is as follows:

1. In what EFL aspects and skills is translation used as a learning strategy by EFL learners in a public university in Indonesia?

II. METHODS

Participants

There were 71 first year university students majoring in English Education who took part in this study. However, only 68 of them returned the questionnaire distributed to them. They were considered as intermediate EFL learners since they have been studying English since they were in elementary school.

Instruments

The participants in this study were required to fill out a questionnaire developed by Liao (2006). The *Inventory for Translation as a Learning Strategy (ITLS)* questionnaire was used to measure the participants' use of translation in their EFL learning and in what EFL aspects and skills translation is used as a learning strategy by them. It comprises 28 items measuring how translation is used to learn English skills and aspects on a 5-point Likert scale following each item ranging from 1 (strongly disagree) to 5 (strongly agree). The questionnaire was translated from English into Indonesian so that the statements and/or questions in the questionnaires could be easily understood by the participants.

Data Analyses

The collected data in this study were analyzed quantitatively by using SPSS software through *descriptive statistics* which was used to summarize the participants' responses to the ITLS to look at in what EFL aspects and skills translation is used as a learning strategy by EFL learners in a public university in Indonesia. The patterns of translation as learning strategy were analyzed by examining the frequency, mean, and standard deviation within the whole participant group. Correlation coefficients were used to assess the validity of the ITLS ($0.00 < 0.05$), and Cronbach's was used to determine the measure's reliability ($0.907 > 0.05$). The criteria to describe the use of translation as a learning strategy were as follows: total mean score $M > 3.5 = \text{High}$, $M \geq 3 - 3.5 = \text{Medium}$, and $M < 3 = \text{Low}$.

III. RESULTS AND DISCUSSION

Participants' Demographic Information

The participants in this study were 68 EFL learners who were in the very first semester. As shown in the Table 3.1 below, 20 students are male (29.4%) and 48 of them are female (10.6%).

Table 3.1 Number of participants who took part in this study

No.	Sex	Frequency	Percent
1.	M	20	29.4
2.	F	48	70.6
Total		68	100.0

M: Male, F: Female

In addition, most of the participants have learned English for 12 years (36.8%). The minimum length of exposure to English learning is six years (2.9%), the maximum is 16 years (1.5%), and the mean of the participants' length of exposure to English learning is 10.93 years as shown in the Table 3.2 below.

Table 3.2 Participants' length of exposure to English learning (year)

No.	Length of exposure	Frequency	Percent
1.	6	2	2.9
2.	7	1	1.5
3.	8	2	2.9
4.	9	8	11.8
5.	10	19	27.9
6.	11	1	1.5
7.	12	25	36.8
8.	13	7	10.3
9.	14	2	2.9
10.	16	1	1.5
Total		68	100.0
Mean		10.93	
Minimum		6	
Maximum		16	

Descriptive Analysis of the ITLS

The participants in this study were required to rate 28 statements on a 5-point Likert scale ranging from 1 (strongly disagree) to 5 (strongly agree). Their scores were then

calculated through *Descriptive Statistics* to look at if the participants frequently make use of translation as their learning strategy. The means and standard deviations for the ITLS items are shown in Table 3.3 below. Out of 28 items in the ITLS, the 21 most frequently used strategies (Items 17, 18, 19, 12, 3, 13, 15, 1, 5, 4, 14, 7, 2, 11, 23, 9, 16, 26, 6, 21, and 20) receive high means ($M > 3.5$), six items (Items 27, 22, 25, 10, 8, and 28) fall into medium use of strategies ($M \geq 3 - 3.5$), and one item (Item 24) is the least used strategy ($M < 3$).

Table 3.3 Means and standard deviations for the ITLS items

No.	Item Description	N	Mean	SD
1.	When reading an English text, I first translate it into Indonesian in my mind to help me understand its meaning.	68	3.96	.984
2.	I read Indonesian translations in the course reference book to help me better understand English articles in the textbook.	68	3.82	.752
3.	After I read English articles, I use an available Indonesian translation to check if my comprehension is correct.	68	4.04	.871
4.	To write in English, I first brainstorm about the topic in Indonesian.	68	3.87	.809
5.	When I write in English, I first think in Indonesian and then translate my ideas into English.	68	3.90	1.010
6.	I write Indonesian outlines for my English compositions.	68	3.66	1.074
7.	When I listen to English, I first translate the English utterances into Indonesian to help me understand the meanings.	68	3.84	.956
8.	I read the Indonesian translation scripts before I listen to instructional English tapes or CDs.	68	3.04	.937
9.	When I watch English TV or movies, I use Indonesian subtitles to check my comprehension.	68	3.76	.979
10.	I listen to or read Indonesian news first in order to understand English radio/TV news better.	68	3.21	.986
11.	When speaking English, I first think of what I want to say in Indonesian and then translate it into English.	68	3.81	1.055
12.	If I forget certain English words or expressions in the middle of conversation, I translate from Indonesian into English to help me keep the conversation going.	68	4.13	.771
13.	I memorize the meaning of new English vocabulary words by remembering their Indonesian translation.	68	3.97	.846
14.	I learn English grammar through Indonesian explanations of the English grammatical rules.	68	3.85	.833
15.	I use Indonesian translation of grammatical terms such as parts of speech, tenses, and agreements to help me	68	3.96	.762

	clarify the roles of the grammatical parts of English sentences.			
16.	I learn English idioms and phrases by reading their Indonesian translation.	68	3.75	.780
17.	I use English-Indonesian dictionaries to help myself learn English.	68	4.32	.800
18.	I use Indonesian-English dictionaries to help myself learn English.	68	4.25	.904
19.	I use an electronic translation machine to help myself learn English.	68	4.22	.895
20.	If I do not understand something in English, I will ask other people to translate it into Indonesian for me.	68	3.54	.905
21.	I ask questions about how an Indonesian expression can be translated into English.	68	3.60	.883
22.	When the teacher assigns English articles for reading, I work with others to translate them.	68	3.46	.800
23.	I practice mentally translating my thoughts from Indonesian to English in various situations.	68	3.78	.826
24.	I take notes in Indonesian in my English class.	68	2.94	.912
25.	I write Indonesian translations in my English textbooks.	68	3.28	.960
26.	I try to clarify the differences and similarities between Indonesian and English through translation.	68	3.69	.815
27*.	When reading English, I try to grasp the meaning of what I read without thinking of Indonesian equivalents.	68	3.47	1.000
28*.	When speaking English, I think of what I want to say in English without thinking first in Indonesian.	68	3.01	1.044

N: Population Size, SD: Standard Deviation

**The scores of the items 27 and 28 are reversed.*

According to the results shown in Table 3.3 above, it can be said that most of the EFL learners in Indonesia still make use of translation as their EFL learning strategy frequently. To make it clear and more logical, based on the ITLS items, five composite strategy variables are constructed and summarized (Liao, 2006:14) as follows.

Table 3.4 Composite Strategy Variables

Variable	Description
S1	Strategies to enhance English skills.
S2	Strategies to learn English forms and structures such as vocabulary, idioms, phrases, and grammar.
S3	Strategies to avoid the use of the first language (L1) when using English, to practice translating, and to clarify the differences and similarities between Indonesian and English.
S4	Strategies to interact with other people.

S5	Strategies to use learning aids such as dictionaries and to take notes.
----	---

Based on Table 3.4 above, it can be said that EFL learners make use of translation as their learning strategy to enhance their English skills, to learn English forms and structures, to avoid the use of L1 when using English, to practice translating and to clarify the differences and similarities between Indonesian and English. In addition, they also use translation for learning English through bilingual dictionaries and notes as well as to interact with other people. The following are the results of descriptive statistics of each composite strategy variable.

Table 3.5 S1 Composite Strategy Variables

	N	Mean	Std. Deviation
1. When reading an English text, I first translate it into Indonesian in my mind to help me understand its meaning.	68	3.96	.984
2. When I write in English, I first think in Indonesian and then translate my ideas into English.	68	3.90	1.010
4. To write in English, I first brainstorm about the topic in Indonesian.	68	3.87	.809
7. When I listen to English, I first translate the English utterances into Indonesian to help me understand the meanings.	68	3.84	.956
2. I read Indonesian translations in the course reference book to help me better understand English articles in the textbook.	68	3.82	.752
11. When speaking English, I first think of what I want to say in Indonesian and then translate it into English.	68	3.81	1.055
23. I practice mentally translating my thoughts from Indonesian to English in various situations.	68	3.78	.826
9. When I watch English TV or movies, I use Indonesian subtitles to check my comprehension.	68	3.76	.979
3. I write Indonesian outlines for my English compositions.	68	3.66	1.074
10. I listen to or read Indonesian news first in order to understand English radio/TV news better.	68	3.21	.986
8. I read the Indonesian translation scripts before I listen to instructional English	68	3.04	.937

tapes or CDs.	
Valid N (listwise)	68

According to Table 3.5 above, it can be said that translation is used as a learning strategy to enhance English skills in terms of reading, writing, listening, and speaking. They also practice mental translations from Indonesian into English in various situations. Translation as a learning strategy which is most frequently used to enhance English skills by the EFL learners is stated in Items 1, 5, 4, 7, 2, 11, 23, 9, and 6. These nine items receive high means ($M > 3.5$).

Table 3.6 S2 Composite Strategy Variables

	N	Mean	Std. Deviation
13. I memorize the meaning of new English vocabulary words by remembering their Indonesian translation.	68	3.97	.846
14. I learn English grammar through Indonesian explanations of the English grammatical rules.	68	3.85	.833
16. I learn English idioms and phrases by reading their Indonesian translation.	68	3.75	.780
Valid N (listwise)	68		

In addition, in Table 3.6 above, it is stated that translation as an EFL learning strategy is also frequently used to help them memorize the meaning of new English vocabulary words, learn English grammatical rules, and learn English idioms and phrases (Items 13, 14, and 16). All of the items are the most frequently used strategies to learn English forms and structures, they receive high means ($M > 3.5$).

Table 3.7 S3 Composite Strategy Variables

	N	Mean	Std. Deviation
12. If I forget certain English words or expressions in the middle of conversation, I translate from Indonesian into English to help me keep the conversation going.	68	4.13	.771
3. After I read English articles, I use an available Indonesian translation to check if my comprehension is correct.	68	4.04	.871
15. I use Indonesian translation of grammatical terms such as parts of speech, tenses, and agreements to help me clarify the roles of the grammatical	68	3.96	.762

	parts of English sentences.			
26.	I try to clarify the differences and similarities between Indonesian and English through translation.	68	3.69	.815
27.	When reading English, I try to grasp the meaning of what I read without thinking of Indonesian equivalents.	68	3.47	1.000
28.	When speaking English, I think of what I want to say in English without thinking first in Indonesian.	68	3.01	1.044
Valid N (listwise)		68		

They also practice translating from Indonesian into English when they forget certain English words or expressions in the middle of a conversation, use an available Indonesian translation to check and clarify if their comprehension about English articles is correct. For learning English grammar, they also use Indonesian translation of grammatical terms to help them clarify the roles of the grammatical parts and the differences and similarities between Indonesian and English. However, to avoid using Indonesian in EFL learning, they try not to think first in their native language, Indonesian, when reading English. Similarly, when speaking English, they try not to think first in Indonesian (Items 27 and 28). In these composite variables, translation as a learning strategy is most frequently used to keep the conversation going (Item 12), to check if their comprehension is correct (Item 3), to learn English grammar and to clarify the differences and similarities between Indonesian and English (Items 15 and 26). These four items received high means ($M > 3.5$).

Table 3.8 S4 Composite Strategy Variables

		N	Mean	Std. Deviation
21.	I ask questions about how an Indonesian expression can be translated into English.	68	3.60	.883
20.	If I do not understand something in English, I will ask other people to translate it into Indonesian for me.	68	3.54	.905
22.	When the teacher assigns English articles for reading, I work with others to translate them.	68	3.46	.800
Valid N (listwise)		68		

Moreover, as Table 3.8 above shows, they also interact with other people through translation in EFL learning. They ask other people how an Indonesian expression is translated into English and vice versa. They also work together collaboratively to learn English as a foreign language (Items 21, 20, and 22). The most frequently used

translation as learning strategies to learn English through interaction with other people include Items 21 and 20. These two items receive high means ($M > 3.5$).

Table 3.9 S5 Composite Strategy Variables

	N	Mean	Std. Deviation
17. I use English-Indonesian dictionaries to help myself learn English.	68	4.32	.800
18. I use Indonesian-English dictionaries to help myself learn English.	68	4.25	.904
19. I use an electronic translation machine to help myself learn English.	68	4.22	.895
25. I write Indonesian translations in my English textbooks.	68	3.28	.960
24. I take notes in Indonesian in my English class.	68	2.94	.912
Valid N (listwise)	68		

In order to help them learn English as a foreign language in Indonesia, As shown in Table 3.9 above, they also resort to electronic translation machines and Indonesian – English and English – Indonesian dictionaries (Items 17, 18, 19). They also write Indonesian translations in their English books during their EFL learning (Item 25). Here, the most frequently used translation strategies include Items 17, 18, and 19) which means that they cannot avoid bilingual dictionaries for EFL learning. These three items receive high means ($M > 3.5$). However, they do not practice note taking in Indonesian when learning English in the classroom very much (Item 24) – this is the least used strategy by the EFL learners in Indonesia.

Based on the results above, it can explicitly be stated that translation as an EFL learning strategy is still frequently used by EFL learners in Indonesia. This study reveals that participants still make use of EFL learning strategy involving translation to enhance English skills (reading, writing, listening, and speaking). In addition, the strategy is also used to learn forms and structures such as vocabulary, idioms and phrases, and grammar.

The participants also report using translation to keep their conversation going, to check if their comprehension is correct, to clarify the grammatical parts of English sentences and to clarify the differences and similarities between Indonesian and English. Besides, they further report using translation to interact with other people and as their learning aids which include their use of English – Indonesian dictionary, Indonesian – English dictionary, and electronic translation machine.

These findings are consistent with findings stated by Liao (2006) that students most frequently use translation to learn English vocabulary, idioms, phrases, and grammar, to read, write, speak, and to check their reading and listening comprehension. In

addition, translation can help students improve their reading, speaking, writing, vocabulary, and grammar understanding (Dagilienè, 2012). These research findings are also in line with findings of other studies. Karimian & Talebinejad (2013) state that translation is used as a learning strategy by students to comprehend, remember, and produce English. Al-Musawi (2014) also states that Arab students most frequently use strategies involving translation to learn English vocabulary, to read, and to write, to check reading and listening comprehension. They also use translation for learning aids and to interact with other people in their L1 to better understand English. Besides, translation plays a vital role in students' English learning (Aktekin & Gliniecki, 2015). They further state that translation is a positive learning resource for students to comprehend, memorize, and produce better English, to acquire English skills, and to complete various English tasks. Mutlu, Bayram, & Demirbukan (2015) also state that adult English learners use translation to develop their English skills such as reading, listening, writing, speaking, and to learn English vocabulary.

Therefore, it can without any doubt be stated to confirm other findings that translation still exists in ELF learning, especially in Indonesia. It is still used most of the time for learning and comprehending English.

IV. CONCLUSION AND SUGGESTIONS

This present study only looks at EFL learners' use of translation in their EFL learning in Indonesia.

Indonesian EFL learners make use of translation as their learning strategy for learning EFL. They still make use of EFL learning strategy involving translation to enhance English skills (reading, writing, listening, and speaking). In addition, the strategy is also used to learn forms and structures such as vocabulary, idioms and phrases, and grammar. They also report using translation to keep their conversation going, to check if their comprehension is correct, to clarify the grammatical parts of English sentences and to clarify the differences and similarities between Indonesian and English. Besides, they further report using translation to interact with other people and as their learning aids which include the use of English – Indonesian dictionary, Indonesian – English dictionary, and electronic translation machine.

These findings are in line with many other similar studies conducted in other settings. Thus, the empirical evidence explicitly explains that translation still exists and cannot be avoided in EFL learning as a means to learn the language.

This study also has implications for EFL teaching and learning based on the empirical evidence and findings. Therefore, translation or inclusion of learners' first language should be allowed to involve at their initial stages of EFL learning in order for them to be able to comprehend English much more easily. Teachers should also

provide space for translation in teaching English skills, vocabulary, grammar, and idioms and phrases, especially to elementary EFL learners.

This study, however, also has some limitations. Although this study is able to describe EFL learners' use of translation as their EFL learning strategy, this study was carried out in a small sample size (n=68). Therefore, adequate number of subjects from different proficiency levels and background are required for future research to provide more precise conclusions. In addition, more advanced statistical analyses with more various variables are also required to provide more reliable findings. To support the quantitative data, qualitative instruments such as interviews may be effective to get a deeper overview on the use of translation in EFL learning.

REFERENCES

- Aktekin, N. Ç., & Gliniecki, A. U. (2015). ELT Students' beliefs about and strategy use of translation. *International Online Journal of Education and Teaching (IOJET)*, 2(1), 12–24.
- Al-Musawi, N. M. (2014). Strategic use of translation in learning English as a foreign language (EFL) among Bahrain university students. *Comprehensive Psychology*, 3(4), 10.03.IT.3.4. <https://doi.org/10.2466/10.03.IT.3.4>
- Dagilienė, I. (2012). Translation as a learning method in English language teaching. *Studies About Languages.*, (21), 124–129. <https://doi.org/10.5755/j01.sal.0.21.1469>
- Guerra, A. F. (2014). The usefulness of translation in foreign language learning: Students' attitudes. *International Journal of English Language and Translation Studies*, 2(1), 153–170.
- Karimian, Z., & Talebinejad, M. R. (2013). Students' use of translation as a learning strategy in EFL classroom. *Journal of Language Teaching and Research*, 4(3), 605–610. <https://doi.org/10.4304/jltr.4.3.605-610>
- Liao, P. (2006). EFL learners' beliefs about and strategy use of translation in English learning. *RELC Journal*, 37(2), 191–215. <https://doi.org/10.1177/0033688206067428>
- Mutlu, G., Bayram, D., & Demirbukan, B. (2015). Translation as a learning strategy of Turkish EFL learners. *International Journal on New Trends in Education and Their Implications*, 6(2), 225–234
- Tan, S. (2015). The relationship between English language proficiency and EFL learners' use of translation strategies. *International Journal of Applied Linguistics and Translation*, 1(4), 55–60. <https://doi.org/10.11648/j.ijalt.20150104.11>
- Vermes, A. (2010). Translation in foreign language teaching: a brief overview of pros and cons. *Eger Journal of English Studies X*, 10, 83–93.
- Ying, B. T., Hoon, A. L., Halim, H. A., & Majtanova, M. (2018). Students' beliefs on translation strategy in learning German language. *GEMA Online Journal of Language Studies*, 18(1), 69–86. <https://doi.org/10.17576/gema-2018-1801-05>

About the Author

Gede Eka Putrawan is a lecturer at the Department of Language and Arts Education, Faculty of Teacher Training and Education, University of Lampung, Lampung, Indonesia. He received his first degree in English Language and Literature from Udayana University in 2007, Bali. Then, he continued his studies in 2009 at the same university to get his master's degree in Linguistics and graduated in 2011. His research interest includes translation, translation in EFL teaching and learning, learning strategy, culture in translation, and language maintenance.

ANALYZING CULTURAL TRANSFER IN ELT CLASS OF SENIOR HIGH SCHOOL TEACHERS

Muhammad Sukirlan

Lecturer of Teacher Training and Education Faculty, University of Lampung

muhammad_sukirlan@yahoo.co.id

ABSTRACT

Cross-cultural communicative competence is one of the communication skills the English teachers must possess. When they communicate in English, which is not their first language, they usually experience cultural transfer. Therefore, the objectives of this study were (1) to find out the level of frequency of the teachers when communicating in English with native English speakers, (2) to find out the level of frequency of the teachers traveling abroad, (3) to disseminate the teacher's perception of English learning, (4) to classify the level of teachers' understanding of cultural transfer, (5) to classify the level of teachers' awareness of the differences between Indonesian language culture and English language, and (6) to identify the forms of cultural transfer carried out by English teachers when teaching in the class. The research employed descriptive method and the samples were English teachers who teach in senior high schools both general (SMA) and vocational concentration (SMK). This research involved 31 English teachers who were selected randomly. The instruments used to obtain data were questionnaires, documentation, observation, and interview. The results of this study indicate that (1) the frequency of teachers communicating in English with native English speakers was still very low, (2) the frequency of teachers traveling abroad was still very low, (3) teacher's perception of learning English had not been fully oriented to culture, (4) the level of understanding of teachers on cultural transfer in teaching English is relatively low, (5) the level of teachers' awareness of the differences between Indonesian and English culture was not optimal, and (6) there were four forms of surface-structure transfers carried out by English teacher when teaching in class. From the results of the study it can be concluded that cultural transfers do occur when English teachers teach English in the class. Negative cultural transfers arose because of several things (1) teachers' lack of communicating with native speakers of English, (2) exposure to foreign cultures was still very poor, (3) teachers' lack of using authentic material as teaching materials in the classroom, (4) teachers' absence of designing the teaching that can increase teachers' awareness of authentic English culture

Keywords: *communicative competence, cross culture competence, cultural transfer*

I. INTRODUCTION

Teacher is one of the professions in the world of education. Like other professions, teachers must be professional in carrying out their duties. The teacher's professional attitude is shown by carrying out the teaching tasks responsibly under the guidance of academic ethics, mastering the taught material, and implementing the appropriate teaching technique, and being able to select teaching material relevant to certain level of students in the classroom.

The role of the teacher in the classroom not only serves as a teacher but also as an educator who plays a very important role in achieving the educational goal set by the institution or school unit. In other words teacher is the spearhead in achieving educational goals. Professional teachers are expected to be able to bring students to achieve certain professionalism as specified in the graduate standard. Conversely, unprofessional teachers will certainly not be able to bring students to reach a certain level of professionalism.

According to Indonesian Government Regulation PP No. 19/2005 concerning the National Education Standard (SNP), Article 28 requires teachers to have minimum competency as learning agents at the level of early childhood education (PAUD), basic education (SD), secondary education (SLTP), and upper level education (SLTA). As a learning agent, the teacher must have 4 competencies namely pedagogic competence, personal competence, professional competence, and social competence.

According to Samani (2006), pedagogic competence is defined as the ability to manage learning which includes understanding of students, designing and implementing learning, evaluating learning outcomes, and developing students to actualize their potential. Personality competence covers strong, stable, mature, wise, authoritative, good figure, and noble. Professional competence includes the ability of the teacher to master the discipline he has. An English teacher must have good command of the field of knowledge he taught so as to be able to make students use English as a means of communication according to the level of education they care for.

Social competence includes the ability to communicate and interact effectively with students, fellow educators, parents, and its environment. English teachers must have a high cultural awareness both in the culture of Indonesian as a culture of origin and in English as the target culture. By having several competencies, the English language teacher is expected to be able to improve the communicative competence of students optimally in accordance with the noble values possessed by the Indonesian nation.

There are two reasons why this research is worth doing. First, so far there has been no research analyzing cultural transfer in teaching English in secondary schools in the City of Bandar Lampung. Until quite recently, there is no information related to the teacher's knowledge of the cultural differences between Indonesian culture and English, cultural transfer both by teachers and students in the classroom, and the teacher's perception of English teaching.

Second, according to the results of research related to teaching English shows that teaching English in Indonesia has not achieved optimum results (see Astika, 2000; Alwasilah, 2001; Lengkanawati, 2004; Cahyono & Widiati, 2008; Marcellino, 2008; Setiyadi, 2009, 2011; and Rachmawaty & Hermagustiana, 2010).

Therefore, this study was designed to invent cultural transfers in teaching English in senior high schools. After the study was successfully carried out, the next research was in the form of an English language learning design based on cultural transfer. Specifically,

this research is intended to achieve several objectives (1) to investigate the frequency of the teachers communicating in English with native English speakers, (2) to know the frequency of the teachers traveling abroad, (3) to know the teacher's perception of English learning, (4) to classify the level of understanding of the teacher on the transfer of culture within teaching English, (5) classify the level of teacher awareness of differences between cultures Indonesian in English, and (6) to identify the forms of cultural transfer carried out by the teacher English at when teaching in class?

Communicative competence

The main purpose of learning English is to develop students' communicative competencies namely, that is, students' ability to use English orally and in written forms. The ability to use English includes the ability of students to express a meaning, opinion, feeling as in speaking and writing skills, and students' ability to understand the meaning, opinions, feelings, thoughts as in listening skills and reading skills in a variety of communicative situations. According to Canale and Swain (1980) and Celce-Murcia (1995), communicative competence consists of 5 types, namely linguistic competence (linguistic competence which is also often called grammatical competence), sociolinguistic competence (sociolinguistic competence), discourse competence, strategic competence, and optional competence (actional competence or often called pragmatic competence).

Linguistic competence refers to one's ability to use linguistic elements accurately and acceptably which includes the ability to choose the right vocabulary, the ability to use accurate grammar, and the ability to speak acceptable English words. In order to be able to communicate with, speakers must know and be able to use the rules that apply in the target language. Sociolinguistic competence (sociolinguistic competence) is defined as a person's ability to use English in accordance with the cultural context both in terms of the speaker and the other person. This ability requires a person to understand the culture of both culture in the source language and target language so that there is no miscommunication and communication breaks.

Discourse competence is defined that one must have the ability to compose words into meaningful sentences and one's ability to compose sentences so that they become a discourse that is easily understood by others both in spoken and written language. Strategic competence is the ability of a person to formulate a strategy using the target language especially when conveying messages orally even though it also occurs in written language. To be able to have conversations with other people, several good communication strategies are needed so that there are no unwanted things such as miscommunication, misunderstanding, and even breaking up. A person with good strategic competency will easily do some speaking skills in various situations such as opening a conversation, maintaining a conversation, changing the subject, choosing a topic, and using a communication strategy to overcome communication problems.

The fifth competency is actional competence. This competence refers to one's ability to understand speech acts that are related to the situation and speech events that occur during communication. To understand the function of an utterance, both utterances which

function as expressions to praise or to express complaints, one needs to relate to speech situations and events.

However, in addition to the five communicative competencies, an English teacher must also understand the cultural elements contained in both Indonesian and English because when the teacher teaches English, he or she is actually bringing together two languages, Indonesian and English. Therefore, the English teacher should also have a repertoire of target language culture (in this case English) which is taught because there is a very close relationship between culture and language. The cultural value of a nation or state will be reflected in the language used as a communication tool.

Therefore, English language teachers must also have a cross-cultural communicative competence by which he or she will be able to build communication with people with different cultural backgrounds. A further impact is that the teachers can teach students to communicate with people of different cultural backgrounds so as to reduce misunderstandings when communicating.

Cultural Transfer

The relationship between language and culture is so close that they are almost inseparable from one to another. Someone who learns English will surely get or learn how English people think in expressing meaning. Conversely, someone who is studying British culture can almost certainly be involved in learning English. Lado (1974) suggests that language is a very important reference for someone who is studying a particular culture.

Someone who is learning English must know how English people express the meaning that is generated through English which sometimes differs from the way Indonesians express meaning in Indonesian. In other words, one meaning or concept cannot necessarily be expressed in the same way. For example, the sentence "I cut my finger when I firstly learned to cook" will feel strange in the ears of Indonesian people, even though the sentence with this arrangement is considered correct according to the rules of the English language. For students who do not understand the rules of English language culture will probably utter "My finger was cut when I firstly learned to cook" as as this sentence is from "Jariku tergores sat saya pertama kali memasak".

The transfer of culture from Indonesian to English often occurs both in spoken language and in written language. A person who speaks in English who always apologizes for his mistakes at the end of the speech is one of the cultural transfers from Indonesian into English (see Erfan, 2010).

Another example of cultural transfer is if a student speaks English but still uses Indonesian language rules. For example, in the middle of the learning process suddenly there was a student who asked permission from the English teacher to leave because he wanted to go to the restroom saying "Excuse Sir, can I go to the small room? Inastead of saying "Excuse me Sir, can I go to the rest room?"

Students accidentally transfer culture from Indonesian to English by calling "kamar kecil" as "small rooms" because they do not realize how native English speakers express a meaning related to the restroom. The phenomenon of cultural transfers from the target language to the original language or from the original language to another language is very possible. This phenomenon will be the main study in this study.

Form of Cultural Transfer

Cultural transfer is defined as interference caused by cultural differences. For example, Indonesian people who speak English tend to use rules and values to guide their attitudes and actions and ways of thinking with the culture they adopt, namely first culture. This situation triggers miscommunication or may reach the level of misunderstanding of the message delivered between speakers and listeners. If no solution is sought, it will reach intercultural conflict.

According to Melinte (2012) and Zhou (2008), cultural transfer is divided into two major parts, namely Surface-Structure Transfer or just surface-level cultural transfer and Deep-Structure Transfer or the inner-level culture program. Because the second involves psychological factors and tends to be more complex, the second research is rarely done. In other words the first type of culture transfer study (Surface-Structure Transfer) is more often done.

Surface-structure transfer is then divided into five parts:

1. Words or phrases do not exist or are not the same in other languages (target language) even though they can be translated but need explanation because speakers in the target culture cannot understand.
2. A word or phrase has very strong cultural and historical implications, as is the word "cowboy" for Americans.
3. Idioms. This expression is based on ancient legends, religion or historical stories. This kind of statement will certainly be difficult to understand by people from different cultural speakers.
4. Proverbs or slogans. This expression is popular in the general public because it was created by well-known public figures.
5. Certain euphemisms or sentences. This phrase is different in different societies. These five forms of cultural transfer will become the material for learning in this study because by looking at these five forms, it can be illustrated about the cultural transfer carried out by the teacher teaching English as a foreign language in Indonesia.

Culture in Language Teaching

It has been explained in the previous section that there is a close relationship between language and culture. The relationship between the two is almost inseparable because when someone learns the culture of a nation it will definitely involve language learning. In other words, an effective way to study the culture of an area is to involve yourself learning the local language. Instead of understanding the meaning of an expression in a particular language, one must learn the local cultural language because the nature of language is a symbol to express a meaning. This statement is in line with Troike

who points out that language is a composed of culture. In other words language is the main component of culture.

Teacher who teaches English is the agent who should be able to introduce how the British people the meaning into English, which would be very different from the way Indonesian people bring meaning into Indonesian. Melinte (2012) states that when learning a foreign language, students will learn the culture of the language whether it is explicitly stated in the curriculum or not. McLeod (1976) also states that by teaching someone's language will automatically teach.

From the statements above it can be inferred that someone who learns a particular language will automatically learn the culture. The teacher who teaches English, will implicitly teach the prevailing culture in society who uses English. The teacher must explicitly teach how the mindset, perspective, value system, habits carried out by English people so that students are able to communicate well without causing misunderstanding.

II. METHODS

This research involved 31 teachers who teach English at the senior high school level both high school (SMA) and vocational high school (SMK). The subjects of this study were taken randomly. They have ranges of social background namely, teaching experience, age, type of school, and school status. The research data were gathered by using several instruments, namely, observation forms, document analysis, recording of teacher's utterances while teaching, recording of students' utterances following lessons, interviews with English teachers, and questionnaires. The data were, then, collected through questionnaires and analyzed through coding, categorization, identification, and interpretation or interpretation in accordance with the theory used, namely surface-structure transfer analysis. After the data has been successfully analyzed, researchers interpret or interpret it according to the relevant theory to get a conclusion.

III. RESULTS AND DISCUSSIONS

In this sub-chapter we can report that the research subjects were 31 teachers who taught English at the senior high school level both high school and vocational high school. The best reason is at the advanced level. The subjects of this study were taken randomly. In this study it can be reported that the number of subjects that can be studied is 31 teachers. From selected subjects it can be reported several information related to teaching experience, age, type of school, and school status.

First, what we can report is related to the teacher's teaching experience. Of these, the average teaching experience is 8 years 6 months (8.6 years). The longest experience of teaching is 14 years and the shortest experience is 7 years. In detail we can report that experienced teachers teaching 14 years amounted to 2 people (6.4%), 13 years 1 person (3.0%), 10 years 3 people (9.6%), 9 years 2 people (6, 4%), 8 years 19 people (61.2%), and 7 years totaling 4 people (12.9%). For more details, we present it in table 1 below.

Table 1 Teaching Experience

No.	Teaching experience	Total	Percentage
1.	14 years	2	6,4%
2.	13 years	1	3,0%
3.	10 years	3	9,6%
4.	9 years	2	6,4%
5.	8 years	19	61,2%
6.	7 years	4	12,9 %

The second is the age of the teacher. The average age of teachers teaching English is 32 years. We can report in detail that the teacher's age range is between 26 and 45 years. Teachers in the age range of 26 to 30 years amounted to 12 people, ranging from 31 to 35 years totaling 15 people, ranging in age from 36 to 40 years totaling 1 person, and the range of 41 to 45 years was 3 people. For more details, we can report in table 2 below.

Table 2 Ages of Teacher

No.	Age	Total	Percentage
1.	26 ≤ 30 years	12	37,2%
2	31 ≤ 35 years	15	48,3%
3	36 ≤ 40 years	15	3,2%
4.	41 ≤ 45 years	3	9,6%

The third is the location whereby the teachers teach based on the type of school whether from high school (SMA) or vocational high school (SMK). Of the 31 teachers who teach there are 11 teachers who teach in vocational schools (35.5%) and 20 teachers who teach in high school (64.5%). For more details, see table 3 below.

Table 3 Types of School

No.	Types of School	total	Percentage
1.	Senior High School	20	64,5%
2.	Senior High Vocational School	11	35.5%

The fourth is the school origin in which the teacher teach based on the status of the school whether public or private. Of the 31 teachers who teach there are 10 teachers who teach in public schools (32.2%) and 21 teachers who teach privately (68.8%). For more details, see table 4 below.

Table 4 School Category

No.	School Category	Total	Percentage
1.	State School	10	32,2,5%
2.	Private	21	68,8%

This sub-section reports on the results of research related to the six research questions namely (1) how often do the teachers communicate with native English speakers? (2) how often do the teachers travel abroad?, (3) what is the teacher's perception of English learning ?, (4) how far do the teacher understand the cultural transfer, (5) Is the teacher aware of the differences between Indonesian culture and English, and (6) What forms of cultural transfer conducted by an English teacher when teaching in class?

The Frequency of Teachers Communicating with Native English Speakers

This section answers the first research question "How often do teachers communicate with native English speakers? To answer this question, researchers distributed questionnaires. This questionnaire asks the level of frequency of teachers communicating with native speakers of English (English Native Speaker). The answers to this questionnaire are divided into 4 categories, not at all, once, often, and very often.

After the questionnaire was distributed to respondents, it can be reported that the respondents who answered were not at all 12 people (38.7%), at one time 14 people (45.2%), often as many as 4 people (12.9%), and very 1 person (3.2%). Table 5 below provides an overview of the level of frequency of teachers communicating with native English speakers.

Table 5 Teachers' Frequency of Communicating with Native Speaker

Teachers' Frequency of Communicating with Native Speaker	Number	Percentage
Never	12	38,7%
Once in a while	14	45,2%
Often	4	12,9%
Very often	1	25,8%
TOTAL	31	100%

The Frequency of Teachers Traveling Abroad

This section answers the second research question "How often do teachers travel abroad? To answer this question, researchers distributed questionnaires. This questionnaire asks the frequency of teachers traveling abroad. The answers to this questionnaire are divided into 4 categories, not at all, once, often, and very often.

After the questionnaire was distributed to the respondent, it can be reported that the respondents who answered were not at all as many as 28 people (90.3%), once upon a time as many as 3 people (9.7%), often no one answered (0%), and very seditious also no one answered (0%). The following table 6 provides an overview of the frequency of teachers traveling abroad.

Table 6 Teachers' Frequency of Traveling abroad

Teachers' Frequency of Traveling abroad	Number	Percentage
Never	28	90,3%
Once in a while	3	9,7%
Often	0	0%
Very often	0	0%
TOTAL	31	100%

Teacher's Perception of English Learning

This sub-section answers the third research question "To what extent does the teacher's perception of English learning? To answer this question, researchers distributed questionnaires. This questionnaire asks the teacher's opinion on the notion of teaching English. Respondents were released to give as much libel as possible about the understanding of teaching English. After the questionnaire is distributed, the answers given by the teacher are categorized into 5 groups.

The first group was teachers who thought that the purpose of teaching English was to be able to make 23 students communicate in English (74.2%). The two teachers who thought that the purpose of teaching English was to enable students to master 4 language skills, namely listening, speaking, reading and writing in English, totaling 4 teachers (12.9%).

Third, teachers who argue that the purpose of teaching English is to create 1 teacher's motivation to study English are (3.2%). Fourth, the teacher argues that the purpose of teaching English is to transfer linguistic knowledge to 1 teacher (3.2%). Fifth, the teacher argues that the purpose of teaching English is to enable students to have language skills and have a cultural insight into the target language culture, amounting to 2 teachers (6.4%). Table 7 below provides an overview of perceptions about teaching English.

Table 7 Teachers' Perception on Teaching English

No.	Teachers' Perception on Teaching English	Number	Percentage
1.	tujuan mengajar bahasa Inggris berujuan untuk dapat membuat siswa berkomunikasi dalam bahas Inggris The objective of teaching English is to make students able to communicate in English.	23	74.2%
2	tujuan mengajar bahasa Inggris adalah untuk dapat membuat siswa menguasai 4 ketrampilan berbahasa yakni, menyimak, berbicara, membaca, dan menulis dalam bahasa Inggris. The objective of teaching English is to master the four language skills.	4	12.9 %

3	tujuan mengajar bahasa Inggris adalah untuk menciptakan motivasi agar siswa giat belajar bahasa Inggris The objective of teaching English is to motivate the students to learn English.	1	3.2%
4	bahwa tujuan mengajarkan bahasa Inggris adalah untuk mentransfer pengetahuan tentang kebahasaan The objective of teaching English is to transfer the language knowledge.	1	3.2%
5	tujuan mengajar bahasa Inggris adalah untuk dapat membuat siswa memiliki ketrampilan berbahasa dan memiliki wawasan kebudayaan atas bahasa yang diajarkan The objective of teaching English is to make students to have language skill and to know the target language culture.	2	6.4%

Understanding of Cultural Transfer

This sub-section answers the fourth research question, namely, "To what extent do teachers understand the transfer of culture in teaching English? To answer this question, the researcher conducted a written test related to understanding authentic English sentences. In this study researchers used 2 types of tests namely, translating and responding to certain expressions.

In the translation test, the respondents were given sentences in Indonesian, then they were asked to choose two choices of expressions that were grammatically correct according to English grammar, but not commonly used by native English speakers.

For the expression "*Baju wanita itu robek saat duduk.*", the number of respondents who chose unusual or unacceptable expressions "Her dress was torn when she sat down" totaled 25 people (81%), while those who chose the usual or acceptable phrase " She wrote her dress when she sat down, there were 6 people (19%).

For the expression "*Awas lantainya licin*" the number of respondents who chose unusual or unacceptable expressions "Be careful, the floor is slippery" amounted to 26 people (84%), while the number of respondents who translated the usual phrase or accepted "Mind your steps "There are 5 people (16%).

For the expression "*Jariku tergores saat saya pertama kali belajar memasak*" the number of respondents who chose unusual or unacceptable expressions "My finger scratched when I learned to cook" amounted to 24 people (77.4%) while the number of respondents who chose the usual or acceptable phrase there are 7 people (22.6%).

For the expression "*Apakah kursi ini sudah ada yang punya?*" The number of respondents who chose an unusual phrase or they did not accept "Does someone take this seat?"

Amounted to 18 people (58%), while the number of respondents who chose the phrase that was common or acceptable "Is this seat taken? "There were 13 people (42%).

For the expression "Can I come in?" The number of respondents who chose an unusual phrase (improper phrase) "No you can't?" amounted to 26 people (84%), while the number of respondents who chose the phrase that was common or acceptable "I am afraid not? Amounted to only 5 people (16%).

For the expression " *Rumah saya sangat dekat dengan perpustakaan*" the number of respondents who choose unusual or unacceptable idioms (My house is very near the library) is 20 people (65%), while the number of respondents who choose expressions (idioms) what is common or acceptable "there are 11 people (35%).

For the expression "*Baiklah, tanpa buang waktu lama, mari kita sambut Mr. Tan*" The number of respondents who voted with unusual or unacceptable expressions "Well without wasting time, please welcome Mr. Tan" there were 25 people (82%), while the number respondents who choose the usual expression or accept "Well, without further a due, please note Mr. Tan" there are 6 people (19%).

For the expression "*Saya selalu mendapat banyak masalah dengan teman saya*" the number of respondents who choose unusual idioms or do not accept "I always have many problems with my friend" there are 27 people (87%), while the number of respondents who choose expressions (idiom) which is normal or acceptable "I always have massive row with my friend" there are 4 people (13%).

For the expression "*Bus ini dilengkapi dengan kamar kecil*" the number of respondents who choose unusual or unacceptable idioms (This bus is equipped with a small room) there are 13 people (42%), while the number of respondents who choose expressions (idioms) the usual or acceptable "This bus is equipped with a rest room" there are 18 people (58%).

For the phrase "Umm ... there is a scratch ... just above the brand name" the number of respondents who respond with unusual or unacceptable idioms, "Yes, it happened last week" there are 23 people (74%) , while the number of respondents who respond with expressions (idioms) that are common or accept "Yes, I made it last week" there are 8 people (26%). Table 8 below gives an overview of the teacher's knowledge of cultural transfer.

Table 8 Teachers' Knowledge on Cultural Transfer

No.	Expression	Number	Percentage
1.	<i>"Baju wanita itu robek saat duduk."</i>		
	a. Her dress was torn when she sat down.	25	81%
	b. She tore her dress when she sat down	6	19%

2.	<i>“Awat lantainya licin!”</i>		
	a. Mind your steps!	5	16%
	b. Be careful, the floor is slippery!	26	84%
3.	<i>“Jariku tergores saat saya belajar memasak.”</i>		
	a. I scratched my finger when I learned to cook.	7	22.5%
	b. My finger was scratched when I learned to cook.	24	77.4%
4	<i>“Apakah kursi ini sudah ada yang punya?”</i>		
	a. Is this seat taken?	13	42%
	b. Does someone take this seat?	18	58%
5	Can I come in?		
	a. No you can't.	26	84%
	b. I am afraid not.	5	16%
6	<i>6. “Rumah saya sangat dekat dengan perpustakaan.”</i>		
	a. My house is very near the library.	20	65%
	b. My house is only a stone throw from library.	11	35%
7	<i>“Baiklah, tanpa buang waktu lama, mari kita sambut Mr. Tan.”</i>		
	a. Well, without wasting time, please welcome Mr. Tan.	25	81%
	b. Well, without further a due, please welcome Mr. Tan.	6	19%
8	<i>“Saya selalu mendapat banyak masalah dengan teman saya.”</i>		
	a. I always have many problems with my friends.	27	87%
	b. I always have massive row with my friends.	4	13%
9	<i>“Bus ini dilengkapi dengan kamar kecil</i>		
	a. This bus is equiped with the small room.	13	42%
	b. This bus is equiped with the rest room.	18	58%
10	<i>“Umm...there is a scratch....just above the brand name.”</i>		
	a. Yes, it happened last week.	23	74%
	b. Yes, I made it last week	6	26%

Indonesian Language Culture Awareness in English

This sub-chapter answers the fifth research question, "Is the teacher aware of the difference between Indonesian and English culture? To answer this question, researchers distributed questionnaires. This questionnaire asks whether the teacher is aware of the cultural differences between Indonesian and English. The answers to this questionnaire are divided into 4 categories: not understanding at all, a little understanding, understanding, and very compelling.

After the questionnaire was distributed to respondents, it can be reported that respondents who answered did not understand at all as many as 2 people (6.5%), little understood as many as 4 people (12.9%), understood as many as 17 people (54.9%), and really

understand as many as 8 people (25.8). Table 9 below provides an overview of the level of teacher awareness of cultural differences between Indonesian and English.

Table 9 Teachers' Awareness of the Difference between Indonesian and English

Teachers' Awareness of the Difference between Indonesian and English	Number	Percentage
Never Understand	2	6,5%
A bit undesrtand	4	12,9%
Understand	17	54,8%
Completely understand	8	25,8%
TOTAL	31	100%

The form of cultural transfer by the teacher

This sub-section answers the sixth research question, namely, "What forms of cultural transfer do English teachers do when teaching in class? To answer this question, the researcher observes when the teacher teaches English which aims to find out whether the teacher transfers culture and classifies the forms of cultural transfer carried out by the teacher.

After conducting observations of teachers who teach English, it turns out the teacher transfers culture from Indonesian (cultural) language into English (cultural) language. The form of cultural transfer carried out is divided into 4 forms.

First, cultural transfers carried out by the teacher in the form of words or phrases. The teacher makes his own terms in accordance with what is believed by way of mentioning English words but phrases that are not common or rigid impressions when reviewed according to English grammar rules. For example, the teacher found it difficult to find the term "*mandi kembang*" in English so the teacher searched for the equivalent flower bathing English phrase.

The teacher also found difficulties in finding the term "suicide" which translates to kill herself, although an English equivalent is also available namely "suicide". This happens because the teacher forgets to mention or maybe the lack of mastery of English vocabulary.

Furthermore, the teacher also experienced a negative cultural transfer when the teacher could not mention cooked water for boiled water, white water for white water, white skin for white skin, and looking around the supermarket for shopping in the supermarket, and deceased which means woman who has passed away.

Table 10 Cultural Transfer in the Form of Phrase or Word

No	Phrase	In English	Total	Percentage
1.	flower bathing	not found	1	3,2%

2.	kill herself	suicide	1	3,2%
3.	cooked water	boiled water	1	3,2%
4.	white water	fresh water	1	3,2%
5.	white skin	fair skin	1	3,2%
6.	looking around in supermarket	window shopping	1	3,2%
7.	<i>almarhumah.</i>	not found	1	3,2%

Second, make a cultural transfer done by the teacher associated with idioms or phrases derived from ancient legends, certain religions, historical stories, which are difficult to understand by other cultural communities. Because most teachers are Muslim, the expressions made by the teacher are influenced by the prevailing expression in the Islamic religion. For example, the teacher opens the class with the words "Before starting our lesson, let me open the class by saying *assalamu 'alaikum warokhmatullohi wabarokatuh*" and by saying "*Bismillahirrohmanirrokhim*", and continue to read prayer. Likewise when ending the teaching the teacher also said goodbye and apology. The following table 11 illustrates the cultural transfers carried out by the teacher.

Table 11 Cultural Transfer Related to Religious Context

No.	Expression Used	Frequency	Percentage
1.	Opening ' <i>alaikum warokhmatullohi wabarokatuh</i> '	29	93,5%
2.	Starting the session ' <i>Bismillahirrohmanirrokhim</i>	29	93,5%
3.	Thanking to God " <i>Ok Students. Now let's thank our God, Allah swt, that today we are healthy.</i>	29	93,5%
4.	Expressing gratitude to God " <i>Alahamdulillahi robbil 'alamin</i> "	29	93,5%
5.	Apologizing " <i>Ok, students apologize if I make mistakes</i> "	29	93,5%
6.	Closing " <i>Ok Students let's close our lesson by saying wassalamu'alaikum warokhmatullohi wabarokatuh</i> "	29	93,5%

Third, the form of cultural transfer made by the teacher is one that is related to proverbs and slogans that actually only apply in Indonesian culture but the teacher tries to express it into English. Even though the teacher has tried to express it in English, the proverb seems rigid and unusual when analyzed in English culture. There are at least two proverbs made by the teacher (1) "It is like a frog in a coconut shell". For Indonesian culture, this proverb comes from "Like a frog in a shell" which describes narrow-minded people. Grammatically this English sentence is nothing wrong, but the cultural meaning of this sentence, if understood by native speakers of English, may feel strange and unusual.

The second proverb made by the teacher is "Rafting toward headwater and swimming toward the edge". Matching this proverb in Indonesian culture is "Assembling upstream,

swimming lively". This proverb illustrates that we struggled first to achieve pleasure later on. Grammatically, this English sentence is nothing wrong, but it is not acceptable because it is unusual for native speakers of English to express the meaning.

The second proverb created by the teacher is "United, we are together and separated we collapse". The equivalent of this slogan is "Unite we are firm, divorce we collapse". This motto is very famous in the colonial period which is used to urge all Indonesian people to unite against the invaders. This sentence is also expressed by the teacher by not violating the rules of English, but in terms of the cultural significance of the English language, it may be unusual. Table 12 below illustrates the proverbs and slogans that teachers make when teaching.

Table 12 Proverb or wise word

No	Proverb	Frequency	Percentage
1.	It is like a frog in a coconut shell.	1	3,2%
2.	Rafting toward headwater and swimming toward the edge.	1	3,2%
3.	United, we are together and separated we collapse.	1	3,2%

Fourth, the form of cultural transfer made by the teacher is related to general expressions which are formulaic expressions and are different from a community of speakers to other speaking communities. There are expressions that are repeatedly stated by the teacher to say that the students' condition is in good condition or not with expressions like this "Are you in a good condition? Another phrase made by the teacher when asking "Where have you been" with the phrase "Where are you from?"

Both expressions made by the teacher above do not violate the rules or rules of the English language, but functionally it is not appropriate to use and is not commonly used to say or ask for a function. The following table 13 illustrates the formulaic expressions made by the teacher when teaching.

Table 13 Formulaic expressions of Indonesian English made by the teacher

No	formulaic expressions of Indonesian English	Standard English	Total	Percentage
1.	Are you in a good condition?	Are you fine?	4	12,9%
2.	Where are you from?	Where have you been?	6	19,4%

From the findings that have been stated in the sub-chapter above, the researcher can interpret that the teacher teaches English must be based on awareness of the existence of cultural differences between Indonesian (native language) and Indonesian (target language). By having an awareness of these differences a teacher will teach potentialities that lead to misunderstandings when an Indonesian speaker communicates with English speakers as suggested by experts (see Troike, 1976; Alwasilah, 2001; Zhang, 2008; and Melinte, 2012).

The second interpretation that researchers can point out is that knowledge about cultural transfers by teachers is still categorized as lacking. This is due to several things (1) the lack of English teachers to communicate with native speakers of English, (2) lack of insight into English culture due to lack of contact with authentic English learning materials, (3) lack of teachers holding visits to countries that use English as a means to communicate, (4) lack of teaching insight that must also be oriented to cross-cultural understanding.

There needs to be training related to the planting of concepts to English teachers that teaching English involves several aspects, namely teaching English language is teaching language skills (listening, speaking, reading, and writing) and teaching aspects of language such as vocabulary, grammar, and pronunciation. Teaching English is developing students' communicative competencies which include linguistic abilities, discerning abilities, sociolinguistic abilities, strategic abilities, and pragmatic abilities. Teaching English is also teaching how students are able to communicate with other speakers of speech communities who have different cultures (cross cultural communication).

IV. CONCLUSIONS AND SUGGESTIONS

Based on the findings and stated in Chapter IV and the interpretations made by the researcher, it can be concluded that:

1. The frequency of teachers communicating in English with native English speakers is still very low.
2. The frequency of teachers traveling abroad is still very low.
3. Teacher's perception of English learning has not been fully oriented to culture.
4. The teacher's level of understanding of the transfer of culture in teaching English is still low.
5. The level of teacher awareness of the difference between Indonesian language culture and English is not yet optimal.
6. There are four forms of surface-structure transfer carried out by the teacher English when teaching in class.

After revealing some of the findings and interpretations related to the research findings, the researchers put forward several suggestions so that later the teacher can improve the level of professionalism in teaching English:

1. The local government gives English teachers the opportunity to communicate with native English speakers by bringing native speakers to schools.

2. The government allocated funds aimed at English language teachers to conduct comparative studies, training, short courses abroad.
3. The government held training for teachers related to the teacher's perception of learning English so that it was also culturally oriented.
4. The government held training for teachers regarding the understanding of teachers on the transfer of culture in teaching English.
5. It is necessary to design teaching materials that are oriented to awareness of the differences between Indonesian and English culture.

REFERENCES

- Alwasilah, A. Chaedar. (2001). *Language, culture, and education: A portrait of contemporary Indonesia*. Bandung. Andira.
- Astika, Gusti. (2000). Task-based approach to teaching English for tour guiding students in efl context. *TEFLIN Journal* Volume 11 Number 1 August 2000
- Cahyono, Bambang Yudi & Widiati, Utami. (2008). The teaching of efl vocabulary in the Indonesian context: The State of the Art. *TEFLIN Journal* Volume 19 Number 1 February 2008
- Canale, M., & Swain, M. (1980). Theoretical bases of communicative approaches to second language teaching and testing. *Applied Linguistics*, 1, 1–47
- Erfan. (2010). Cultural transfer in English speech texts of efl learners. In Cahyono B.Y. (Ed.) *Second language acquisition and English language teaching*. Malang: State University of Malang Press.
- Lado, R. (1974). *Linguistic across culture*. Michigan: The University of Michigan Press.
- Lynch, Brian K. (1996). *Language program evaluation*. Cambridge: Cambridge University Press.
- Lengkanawati, Nenden S. (2004). How learners from different cultural backgrounds learn a foreign language. *Asian EFL Journal*. Volume 6 Issue 1 No. 8
- Marcellino, M. (2008). English language teaching in Indonesia: A continuous challenge in education and cultural diversity. *TEFLIN Journal* Volume 19 Number 1 February 2008
- Melinte, Irina E. (2012). Cultural transfer and the cross-cultural impact of foreign languages. *cultural and linguistic communication*. Volume 2 Issue 1 January/March 2012.
- Rachmawaty, Noor & Hermagustiana, Istanti. (2010). Does retelling technique improve speaking fluency? *TEFLIN Journal* Volume 21 Number 1 February 2010
- Samani, Muchlas. (2006). *Mengenai Sertifikasi Guru di Indonesia*. Jakarta. APPI
- Setiyadi, Ag. Bambang. (2009). *Language learning strategy questionnaire (LLSQ): Step towards the success in teaching English*. Presented at the Professorship Inauguration, November 24, 2009. Bandar Lampung. Lampung University Press.
- Saville-Troike, Muriel. (1976). *Foundations for teaching English as a foreign language: theory and method for multicultural education*. Prentice-Hall, Inc. Englewood Cliff. New Jersey.
- Zhou, Yang. (2008). The impact of cultural transfer on cross-cultural communication. *Asian Social Science*. Vol 4 Number 7, July 2008.

THE USE OF LONG FUNCTIONAL TEXTS WITH LAMPUNG LOCAL WISDOM IN ENGLISH LANGUAGE TEACHING

Agatha Nila Sukma M.

SMP Negeri 20 Bandar Lampung, Indonesia

anilasukma@yahoo.com

ABSTRACT

The rapid growth of knowledge, information, and technology bring positive and negative effects to the society. One of the weaknesses is the decrease of culture including local wisdom of a certain area. Young people who have a role as agents of culture tend to ignore the values of local wisdom. They are more engaged with modernization. They are more familiar with western songs and stories than traditional songs and folktales, for example. This situation causes the decline of local culture and brings influences in students' characters. Hence, education as an important part in building the characters as well as keeping our tradition and culture should facilitate the students. Using teaching materials that include some values of local wisdom is one of the solutions to cope with the problem. In this article, the development of teaching materials especially long functional texts or essays which include Lampung local wisdom can be used in English teaching learning context. The long functional texts used are narrative, descriptive, recount, and procedure texts. The use of those texts is in line with contextual learning model in which the teaching materials should be closely related with the students' life in social and cultural aspect as well.

Keywords: *Lampung local wisdom, long functional texts*

I. INTRODUCTION

The development of knowledge, information, and technology nowadays bring several effects to the society. One is the deculturation in several aspects of life or in other words, local values in Indonesia had been putting aside or leaving behind especially by young generation. Students as a young generation to preserve the tradition and culture are busy with modernization. They even had better sing the newest western or Korean pop songs rather than Indonesian folksongs. They are more excited spending the time with social media than playing traditional games. Local traditions are also ignored by most youngsters. This fact should become a special attention especially in education because this fact can decrease young people's nationality and appreciation to the local cultures. As a result, local cultures will be vanished by the time of the existence of western and Korean cultures. We do remember when Pendet dance, reog dance, and batik had been claimed by other country. There is still possibility for other countries to claim other national cultural heritage if the young generation do not keep it well.

Education based on local wisdom can be a media to keep the local potential and culture. As an unseparated part of culture, local wisdom is local values inherited by our ancestors to generations and are convinced as goodness in certain society. Inserting the local wisdoms in teaching and learning activities at school will hopefully help the preservation of culture and development of students' characters as well.

The local wisdom in this country is really various since Indonesia is an archipelago country with more than seventeen thousand islands that consist of different tribes, religions, and cultures. In Lampung society, the local wisdom is found in local languages, dances, songs, music, folktales, traditional food, and other Lampung traditions. Lampung government has played a good role in keeping the local wisdom by putting Lampung language and tapis handicraft into the curriculum as local subjects. Beside local language and handicraft, some schools in Bandar Lampung have been applying several activities related to Lampung culture such as the extracurricular of Lampung traditional dance and music. These activities rise the students' interests and talents in music and dance as well as keep Lampung cultural heritage.

The mentioned activities are some things that people do to keep the local values. In class, keeping the cultural heritage can also be done by bringing it inside the teaching learning activities. One of them is using long functional texts or essays with Lampung local wisdom in English language learning. Based on 2013 curriculum for SMP, the long functional texts in English subject cover narrative, descriptive, recount, report, and procedure texts. However, in this article the essays used are narrative, descriptive, recount, and procedure.

Interjecting Lampung local wisdom into English teaching learning process is in line with contextual learning in which the materials used are connected to the learners' real life for the purpose of understanding the materials easier. In the other side, when the materials include western cultures, the learners will face difficulties both in cognitive aspects and cultural understanding aspects.

Some experts such as Gail Robinson, Claire Kramersch, and Adrian Holliday in Kumaravadivelu (2003) expand the horizon of culture learning and teaching in second language classroom. Kramersch sees the L2 classroom as a place of struggle between the learners' meaning and those native speakers. Hence, creating contextual learning will help the learners minimize the struggle of finding the concept of learning itself since they can relate it with their own everyday life.

This article aims to be an alternative solution to the English teachers so that the students as young generation will be able to know and keep Lampung cultural heritage by making use of long functional texts with Lampung local wisdom. Besides, the use of long functional texts with Lampung local wisdom can participate in introducing Lampung culture to the national and international world.

II. THEORETICAL REVIEW

It cannot be denied that Indonesia consists of thousand tribes with their cultures, traditions, and religions. Every region has its own culture and distinction that cannot be found in other places in this country including its local wisdom.

Local wisdom can be defined as values inherited from generation to generation and become a truth in certain community or society. According to Kamonthip & Kongprasertamorn (2007), the characteristics of local wisdom include (1) teaching ethics and moral values,

(2) knowledge to teach people to love nature, not to destroy it, (3) inherited by the ancestors of certain society. Meanwhile Kartawinata (2011) sees local wisdom as the implementation of sustainability and ability to live the vision of life, knowledge, and strategies of life in many activities in local society to solve people's needs while protecting the culture at the same time.

The different tribes, religions, and culture in each region in Indonesia produce values of local wisdom that will be interested if they are related to education as an effort to build unity and nationality. Education grows a spirit of building tolerance in diversity that differs in way of viewing, thinking, acting, and so forth (Yamin, 2011).

Regarding those facts, The Regulation of Ministry of Education No. 22 Year 2006 about Standard of Content declares that local content and self improvement activities are an integral part of basic education curriculum. Hence, every unit of education should decide the kind of local content regarding its distinction and potency. The Standard of Content that is centrally arranged cannot accommodate the various kind of local content in every region, therefore otonomy has a role to live the local potencies.

In Lampung province, the government has decided Lampung language as a local content that must be learned by the students. However, learning local content as a part of curriculum is not enough to keep Lampung local wisdom. Internalization of Lampung local wisdom into several subjects may become a solution.

Bringing Lampung local wisdom into English teaching learning process is one alternative to actively live the local tradition and culture. Some research related to English learning with local wisdom had been conducted by some researchers such as Owon (2017), Yamin et al (2016), and Suciani et al (2012). In his research, Owon (2017) developed writing materials of various texts with a theme of Sikka (NTT) local wisdom for junior high school students. The result showed that most of the students were able to improve their writing skill by keeping Sikka local wisdom

Meanwhile, Yamin dkk (2016) conducted a research in junior high schools in Banjarmasin that focused on local wisdom in learning English. The research found that the junior high schools in Banjarmasin had related the learning with the values of local wisdom especially about river preservation and some tradition of Banjarmasin people. The students put a high respect to the values of Banjarmasin local wisdom as the young generation.

Suciani et al (2012) in her research stated that contextual learning that focused on Bali culture in English learning for elementary school was found effective. The students were able to understand the knowledge of English without being desperate with western culture. The collaboration of learning process with the students' socio-cultural life bring positive effects to the students' achievement.

III. DISCUSSIONS

The previous studies above convince that connecting the local wisdom with teaching learning process bring several benefits. In general, the education system that is based on local wisdom becomes the basis of building students' characters because of the values in

it. By using long functional texts especially in English learning, the students as young generation will be able to know and keep Lampung cultural heritage.

The Use of Long Functional Texts with Lampung Local Wisdom

Lampung local wisdom that is inserted into English learning process at school is one of the alternative strategies in keeping the tradition as well as the values of the local wisdom itself. The use of long functional texts with Lampung local wisdom in English learning includes narrative, descriptive, recount, and procedure texts.

Narrative Texts

Narrative texts are essay texts in the form of stories that have a function to entertain the readers/ listeners. The language structure covers Orientation, Complication, and Resolution. The Orientation part introduce the characters and the setting of the story, while the Complication part tells about the conflicts or problems faced by the characters. The solution of the problems was found in the last part of the story that is called Resolution. Narrative texts are found in the form of folktales, fairy tales, fable, or short story. In each story there is moral value that can be learned in our daily life. The moral lesson is no always stated at the end of the story.

In this article, the narrative texts that can be used are in the form of folktales from Lampung such as “Datuk Tuan Budian”, “The Legend of Ranau Lake”, “The Seven Sisters”, “The Origin of Small Anchovies”, “Sultan Domas”, and many others. The use of Lampung folktales enables the students to know more about local folklores and take the moral values from the story as well.

Descriptive Texts

Descriptive texts are texts that provide description of something specifically such as description of people, place, or a certain art. It is obvious that the purpose of this kind of text is to describe specifically about certain topic. The structure of the text includes two main parts; they are Identification and Description. Identification is an introducing part that mentions what is going to be discussed or described in the text, while the Description part discusses the detailed informations about the topic being described.

In this article, the descriptive texts used are about Lampung tradition, traditional dances, traditional handicrafts, or tourism spots in Lampung. The examples are a description of “Cangget Dance”, a description of “Piil Pesenggiri”, a philosophy of life that becomes one Lampung local wisdom (Syani, 2013), a description about “Adat Mepadun”, and any other descriptions about Lampung tradition and Lampung tourism places.

Recount Texts

Recount texts are texts that tells about someone’s experience or events sequencely. The language structure of this text is Orientation, Events, and Closing or Reorientation. As in narrative texts, the Orientation part gives information about characters and setting of the story. Meanwhile the Events are about the series of events in sequence and the last part is closing.

The recount texts in this article are someone's story after visiting Lampung tourism places such as Way Kambas National Park, Siger Tower, Teluk Kiluan, and many others. Telling someone's experience after seeing one Lampung traditional performance or tradition can also be a theme for this text.

Procedure Texts

Procedure texts are special texts that tell the steps of making or doing something in sequence. The language structure of the text includes title, objective, materials, tools, and steps. The title of this text is related with the objective of the text. The procedure texts can be in the form of recipe and manuals.

In this writing, the topic of procedure texts discussed is about recipe of Lampung traditional food such as Seruit and Pindang. Besides, the text can also discuss about the steps of making Lampung traditional handicraft such as sulam tapis.

English learning process that uses long functional texts with Lampung local wisdom is in line with contextual learning that is emphasized in Curriculum 2013. Contextual Teaching Learning (CTL) has four educational pillars called *learning to do*, *learning to know*, *learning to be*, and *learning to live together*. *Learning to do* means that learning is intended to explore the students to enrich themselves in learning experience. *Learning to know* is about learning which is designed by optimizing interaction among the learners' environment physically, socially, and culturally so that the learners are able to build their knowledge and understanding toward their surroundings. *Learning to be* is a learning process that requires the learners to be able to build their knowledge and confidence. The last pillar is *learning to live together*. In this part, the learning process is more focused on the efforts to build the learners' good characters to understand and know pluralism so that they will have positive behaviours in responding the diversity itself.

Beside the four pillars, Contextual Teaching Learning (CTL) has seven main components called constructivism, inquiry, questioning, modelling, learning society, authentic assessment, and reflection. In its implementation by using long functional texts with Lampung local wisdom, those seven complements are found.

According to Johnson (2006), CTL is a learning system that fits the brain in producing meaningful understanding by connecting the cognitive aspects with the contexts of the learners' life. It does not only point out the meaning of certain events but also dig more deeply on the correlation of the environment itself with the assumptions and values of life. Contextual learning model implemented in English language learning using long functional texts with Lampung local wisdom is potential since the learning materials are related to the students' sociocultural life. The students have some prior knowledge about Lampung culture that can help them to comprehend the language structure and skill.

The long functional texts used are in the form of written text or spoken text. The students can choose the examples of the text through internet with some limitations prepared. The examples from various sources will be beneficial for the students to understand the text and to make a conclusion about a certain text.

In the implementation, the teacher should motivate the students to optimize technology for learning media. After getting various examples from the internet or books, they are asked to make a written or spoken text. For example, they can make a video or vlog about a procedure of making Lampung traditional food. Other example is writing a descriptive text about one tourism place in Lampung and then present it in front of the class. They can use Power Point and LCD projector to present the text with some photos or video related to the text. This kind of activity will improve the students' skill in speaking and in using a simple technology.

A nice learning activity can also be found in learning narrative texts. The students can use interesting media such as video, pictures or realia related to the narrative story from Lampung when they retell the story. A more interesting class can also be built when the students present the story in the form of drama.

The Benefit of Using Long Functional Texts with Lampung Local Wisdom

There are several advantages of using long functional texts with Lampung local wisdom. By applying such kind of texts in learning English, the students are able to:

1. comprehend the knowledge or concept of the various texts;
2. build their positive perspective and belief towards their own culture and the fact that cultural identity is a part of national identity;
3. know Lampung folktales as example of narrative texts and take the moral values from the stories as the effort of building the learners' characters;
4. know Lampung tradition and culture through descriptive and recount texts and take part in keeping the heritage;
5. know Lampung tourism places through descriptive and recount texts and also take part in promoting the places;
6. explain and practice the steps of making Lampung traditional food or the steps of making sulam tapis through procedure texts;
7. introduce Lampung tradition, arts, and culture to the international world through the essays in spoken or written texts published in Facebook, Youtube, blog, or any other social media that can be reached by all people in the world;
8. love Lampung tradition and culture so that they will not forget the values of local wisdom in the social life.

IV. CONCLUSIONS AND SUGGESTIONS

The learning that connects the material with the local wisdom and the students' personal life, social, and cultural things will be beneficial in several aspects. The students do not merely learn the materials better but also take various values beyond them. The use of long functional texts with Lampung local wisdom in English learning process is proposed to be a solution of deculturation in Lampung province. The students' background knowledge about Lampung will help them comprehend the texts better since it can be considered as contextual learning. The students also play a role in keeping the local culture as the root of Indonesian identity.

Teachers as a fasilitator in learning process at school have to be brave to make any changes to improve the quality of learning. Any adjustments are needed to ease the students

comprehend the material as well as make efforts in preserving the local wisdom. Bringing the local wisdom into the learning process can be applied combined with any creative media or strategies regarding the development of information and technology especially in learning.

REFERENCES

- Johnson, Elaine B. (2006). *Contextual Teaching and Learning*. Bandung: Mizan Learning Center (MLC).
- Kamonthip & Kongprasertamorn. (2007). Local Wisdom, Environmental Protection and Community Development: The Clam Farmers in Tambon Bangkhunsai, Phetchaburi Province, Thailand, *Manusya: Journal of Humanities* 10.1.
- Kartawinata, A.M. (2011). *Local Wisdom in the Middle of Modernization*. Jakarta: Ministry of Culture and Tourism of the Republic of Indonesia.
- Kumaravadivelu. (2003). *Beyond Methods: Macrostrategies for Language Teaching*. New Haven and London: Yale University Press.
- Owon, R.A.S. April 17, 2018. *Pengembangan Bahan Ajar Menulis Berbagai Jenis Teks Bertema Kearifan Lokal Sikka bagi Siswa SMP*. Retrieved from https://www.researchgate.net/publication/317254300_Pengembangan_Bahan_Ajar_Menulis_Berbagai_Jenis_Teks_Bertema_Kearifan_Lokal_Sikka_Bagi_Siswa_SMP.
- Suciani, N.K., Subur, I.M., & Widanta, I.M.R.J. (2012) Pembelajaran Bahasa Inggris Berkonteks Budaya Bali: Suatu Strategi Pengembangan Budaya Global. *Stilistetika Tahun 1 Volume 1*, November 2012 ISSN 2089-8460
- Syani, A. April 16, 2018. *Kearifan Lokal Sebagai Aset Budaya Bangsa dan Implementasinya dalam Kehidupan Masyarakat*. Retrieved from <http://staff.unila.ac.id/abdulsyani/2013/04/17/kearifan-lokal-sebagai-aset-budaya-bangsa-dan-implementasinya-dalam-kehidupan-masyarakat/>
- Yamin, M. (2011). *Meretas Pendidikan Toleransi*. Malang: Madani.
- Yamin, M., Mu'in, F., & Arini, D.N. (2016). *Kajian Rencana Pelaksanaan Pembelajaran Bahasa Inggris Berkearifan Lokal Tingkat SMPN di Kota Banjarmasin*. Banjarmasin: FKIP Universitas Lambung Mangkurat.

About the Author

Complete Name : Agatha Nila Sukma M., M.Pd
Institution : SMP Negeri 20 Bandar Lampung
Email Address : anilasukma@yahoo.com
Education : *Graduate Program of English Education in Malang State University (2014-2016)
*Undergraduate Program of English Education Study Program in Sanata Dharma University, Yogyakarta (2003-2009)
Research Interest : Writing

AN ANALYSIS OF THEME AND RHEME IN AN ADVERTISEMENT

Yanuaris Yanu Dharmawan

English Department, Universitas Bandar Lampung, Indonesia

yanu@ubl.ac.id

ABSTRACT

Theme and Rheme can be recognized in any kind of sentences. They are very important to understand more on the meaning of the sentence. Here I focus on advertisement in Forbes magazine Indonesia Edition volume 8 issue 11 page 78 on November 2017. I find out the theme and the rheme in every clause in order to get the message as what the author wants to convey. By analyzing the theme and rheme in every clause, it will make easier for us to convey the message. The interaction of theme and rheme oversees how the information in a text develops and is interpreted.

Keywords: *theme, rheme, advertisement*

I. INTRODUCTION

Language accommodates as dispatcher of message to person who reads as the object information. Language is used as a tool to communicate with other people of our abstract thought and feeling, Dharmawan & Saniyati (2016). It is how to convey message like ideas, thoughts, needs, purpose and others. Spoken language is produced by using voice and written language created from phrasing, vocabulary etc. In writing, text ought to be understood easily, Kusuma (2013:01). Nowadays finding the advertisement in English is easy. It can be found not only on the television, newspapers, magazines, etc. There are some brand names of magazine that present English as language used in the advertisement in Indonesia. They are Vogue magazine, Forbes magazine, C and S magazine, and many more.

To interpret the meaning that conveys the message in the advertisement, I have to understand it contextually. English sentence, contextually, is brought by two forms, Theme and Rheme. Gerot and Wignell (1994:104) said that earlier in the clause that represents the idea from the previous one is known as the Theme. The rest of the clause which consists of the new information is called as the rheme. In the Systemic Functional Grammar, *Theme* is understood as "the starting point of the message" (Halliday 1994: 38). It also functioned as "an orienter to the text" (Fries 1995:318), providing a framework for the interpretation of the message. Theme offers the settings for the remainder of the Sentence. Eggins (1994) stated that the content of information in a sentence is flowing from Theme to Rheme, so that it is very important to know it as it conveys the message effectively. Wang (2007) stated that the exchange of information between Theme and Rheme pairings in a text is called as Thematic Progression. At the level of a clause complex (paragraph), the first clause will be taken as the

theme (topic sentence). Whereas at the level of a text, the first clause or clause complex will be regarded as the departure of what the author is going to say. Rheme is the residue of the message in a clause which Theme is developed. Rheme includes what the writer wants to tell about the theme, which should be new and interesting to the reader.

This research uses the advertisement as media to be analyzed. Ary (2010:457) said that content or document analysis is a research method applied to written or visual materials for the purpose of identifying specified characteristics of the material. The materials analyzed can be textbooks, newspapers, web pages, speeches, television programs, advertisements, musical compositions, or any of a host of other types of documents.

II. METHODS

This research is qualitative research. Willig (2001) stated that Qualitative research is concerned with meaning in context as it involves data interpretation. It is to tell systematically the fact and the characteristic of given population or area of interest accurately. It is an inquiry process of understanding that explores a social or human problem. At this case I try to analyze words and conduct the study in a natural setting, Creswell (1998). This research is restricted on not only collecting and arranging the data orderly, but also analyzing and interpreting the meaning of the data.

The data of the research are in the form written ones. The subject of the research is taken from Forbes Magazine Indonesia edition volume 8 issue 11 page 78 on November 2017. Firstly, I try to find the data by collecting the advertisement in Indonesian Forbes magazine and then choose the advertisement as data. The next thing to do is segmenting the sentences onto clauses which then identified into theme and rheme.

III. RESULTS AND DISCUSSION

There are nine clauses existed in advertisement. The brief explanation of each clause as well as each type of theme is described in the following analysis.

Enjoyable Voyage

Theme	Rheme
Unmarked Topical Theme	
Winemaker Beringer	recently launched its largest regional campaign with Trip Advisor to make travel planning more enjoyable.

The rheme ‘‘recently launched its largest regional campaign with Trip Advisor’’ and the next clause is ‘‘to make the travel planning more enjoyable’’. There is a certain purpose in doing the largest regional campaign. The owners of the purpose are ‘‘Winemaker Beringer’’ and ‘‘Trip Advisor’’. The first word that appears, ‘Winemaker Beringer’, becomes the theme. It also indicates that the owner of the plan is Winemaker Beringer. The Trip Advisor is only a

partner or sponsor for the campaign. Indirectly the author wants to convey that the idea comes first from Winemaker Beringer.

Theme	Rheme
Unmarked Topical Theme	
A regional survey Commissioned by the leading Napa Valley wine brand	has revealed that more than one in two Indonesians waste an average of four days of annual leave each year due to poor planning, with a staggering 84% citing work responsibilities as the main culprit.

One that has revealed the explanation about the survey in the rheme “has revealed that more than one in two Indonesians waste an average of four days of annual leave each year due to poor planning, with a staggering 84% citing work responsibilities as the main culprit ” is a regional survey commissioned by the leading Napa Valley wine brand.

The survey above shows that more than one in two Indonesian peoples squander an average annual leave for four days each year due to poor planning, with astonishing 84% mention job responsibilities as the main cause. The keyword is the survey. The survey comes from a regional survey commissioned by the leading Napa Valley wine brand. The survey is as the substantiation for the reader that there are still Indonesians that have poor holiday. Some say because of poor planning and the other say job responsibilities as the main cause. Outright this survey becomes motivation for Winemaker Beringer to make the travel planning more enjoyable.

Theme	Rheme
Marked Topical Theme	
Given that	21% of Indonesians actually fear vacation planning, 13% hate it and do their best to avoid it, with 46% likening vacation planning to being at work,

The rheme of the clause is “21% of Indonesians actually fear vacation planning, 13% hate it and do their best to avoid it, with 46% likening vacation planning to being at work”. The percentages give detail information to the reader. The information tells about Indonesian peoples that have different vacation planning. It becomes substantial to make the readers believe. The rheme here leads to the theme which means that the theme represents the idea while rheme as the explanation. Interestingly the author uses “Given that” theme like this is rarely encountered

Theme	Rheme
Unmarked Topical Theme	
The campaign	will see Beringer and TripAdvisor working together on an integrated campaign to provide ideas and solutions to help people to better enjoy planning their next trip.

The clause in the rheme above "will see Beringer and Trip Advisor working together" becomes partners and work together only for campaigns. The clause refers to the theme. The next clause "on an integrated campaign" is an integrated campaign. The aim of this campaign is in the last clause, "to provide ideas and solutions to help people enjoy planning their next trip". It is to see how Beringer and Trip Advisor work together. It is a challenge for them to create an integrated campaign. Another challenge is to provide ideas and provide solutions for people who plan trips. The key word is campaign.

Theme	Rheme
Marked Topical Theme	
The campaign	Will come to life across the Trip Advisor site with banner ads, a dedicated micro site, social media, in-store, in restaurants and bars, and potentially in airports.

The clause "Will come to life across the Trip Advisor site" is promoted by the campaign. The next clause is "with banner ads, a dedicated microsite, social media, in-store, in restaurants and bars, and potentially in airports." The campaign will appear throughout on Trip Advisor site. It can be banner ads, a dedicated microsite, social media, in-store, in restaurants and bars, and potentially in airports. This campaign will be there in a crowded place. This allows a lot of people to see especially in the airports. In the airports there are a lot of tourists. All over the rheme above explains about where the campaign will be there, and what will they do to promote the campaign. The rheme always explains about theme.

Theme	Rheme
Marked Topical theme	
In response to the findings,	Beringer has launched a campaign to inspire a holiday planning revolution.

Beringer gives the response by launching a campaign. It is done to inspire a holiday planning revolution. In the theme, 'in response to the findings', the author wants to convey what Beringer does. The finding here is the survey and the percentages at the clause before. They do something only to the response of the findings. The rheme in here explains the response of the findings.

Theme	Rheme
Unmarked Topical Theme	
We	want people to see that making vacation planning as social occasion.

The clause in this rheme is “want people to see that making vacation planning as social occasion”. People who want to see vacation planning as social occasion are ‘we’. The key is “we”. ‘We’ here represents the Beringer Company. They hope that the event can be a social occasion which is not only about vacation planning. The author expresses that they have the same desire.

Theme	Rheme
Marked Topical Theme	
A little bit of planning	can have a huge impact on the kind of holiday you experience and its well within everyone’s reach.

The clause “can have a huge impact on the kind of holiday you experience” is an impact from “a little bit of planning” as well as the next clause, “it’s well within everyone’s reach”. The types of vacation you take actually depend on your own planning. If you have a small plan it will have a big impact for your type of holiday. The author puts ‘A little bit of planning’ as the theme. It signals that good or terrible your vacation depends on the plan.

Theme	Rheme
Unmarked Topical Theme	
We	Believe that vacation planning is always better when shared with others over a glass of wine, “says Beringer senior Brand Manager Marcus Ingleby.

“Believe that vacation planning is always better when shared with others over a glass of wine” the meaning is the vacation planning would be better by sharing a glass of wine. The purpose of this opinion is to suggest the reader to believe them. There are people need to be believed and “the people” is “we”. The next clause is “says Beringer senior Brand Manager Marcus Ingleby”. It is also the opinion from Senior brand manager Beringer although I see here that only the senior brand manager who gave his opinion. On the other hand he says ‘we’ at the first time. It means that the company is not only himself. Theme here represents the idea that can be seen.

I find that Themes often appear in the advertisement are ‘we’ and ‘the campaign’. The function of ‘we’ is to get closer with the reader. ‘We’ means the Beringer Company or even all the Beringer employees and also as well as a form of collective responsibility. The function of ‘the campaign’ is to give the clearer clue for the reader. Actually the author explains more about the campaign such as how the campaign is made, what the purpose of the campaign and who are involved in the campaign.

Rhemes often appear, planning, vacation planning, campaign, and Beringer. The author conveys that “it’s all about planning”, vacation planning, campaign and also Beringer. All over the rhemes in the advertisement explain about what Beringer wants, What Trip Advisor does, Why Beringer and Trip Advisor working together, And what actually their purpose, And the explanations. Rheme is about the explanation while theme represents the idea. That is why everything in the rheme always leads to the theme. So when the first time I read the advertisement the first word that appears is going to be reminder. It causes the first word that appears as theme becomes the clue that is discussed in the rheme.

REFERENCES

- Ary, Donald, Jacobs, Lucy C., Razavieh, & Sorensen, C. (2010). *Introduction to Research in Education (8th ed.)*, Belmont, Thomson Wadsworth.
- Creswell, J. W. (1998). *Qualitative Inquiry and Research Design: Choosing among Five Traditions*, Sage Publications, London.
- Dharmawan, Yanuarius Yanu & Saniyati, Mutiatu (2016). Improving Students’ Pronunciation By Using Audio-Visual-Assisted Text, *Proceedings The Fourth International Conference on Education and Language (4th ICEL)*, Universitas Bandar Lampung (UBL), Indonesia, II75-II80.
- Eggins, S. (1994). *An introduction to systemic functional linguistic*, London: Printer Publishers.
- Forbes Magazine Indonesia edition volume 8 issue 11 page 78 on November 2017
- Fries P.H. (1995). Themes, Methods of Development, and Texts, in *On Subject and Theme. A Discourse Functional Perspective*. Ed. by R. Hasan and P.H. Fries, Amsterdam, John Benjamins, pp. 317- 360.
- Gerot, L., & Wignell, P. (1994). *Making Sense of Functional Grammar*, Australia: Gerd Stabler.
- Halliday, M. A. K. (1994). *Introduction to Functional Grammar (2nd ed.)*, London:Arnold.
- Kusuma, Tri Wijayanto (2013). *An Analysis of Theme in Michael Learns To Rocks Song Lyrics*, Kudus, Department of English Education, Faculty of Teacher Training and Education, University of Muria Kudus, Unpublished Thesis.
- Wang, L. (2007). *Theme and Rheme in the Thematic Organization of Text: Implications for Teaching Academic Writing*, Asian EFL Journal, March, Vol.9, No. 1, pp: 164-176. Available at : www.ivsl.org
- Willig, C. (2001). *Introducing Qualitative Research in Psychology*, Open University Press, Buckingham.

About the Author

Complete Name : Yanuarius Yanu Dharmawan
Institution : Universitas Bandar Lampung
Email Address : yanu@ubl.ac.id
Education : Magister Kajian Bahasa Inggris, Universitas Sanata Dharma,
Yogyakarta
Research Interest : English Linguistics

GENDER AND CULTURAL FAMILIARITY IN READING MATERIAL

Elis Susanti¹, Rini Susilowati², Asep Hardiyanto³
STKIP Muhammadiyah Kotabumi^{1,2,3}
Kotabumi-Lampung Utara
weasley.ndha@yahoo.com¹

ABSTRACT

The issue about gender sensitive material and target language cultural material on reading comprehension should be an essential consideration for the English teachers in applying reading material in a reading class. A recommended reading material should be interesting for both male and female students, so it will reveal a good motivation in a teaching and learning process of reading class. Besides, it is known that students' prior knowledge will be one of the factors enable the students easier in comprehending a reading text. This study aimed at investigating the influence of gender and cultural familiarity on students' reading comprehension in which the researcher applied a reading material based gender and cultural familiarity in teaching a reading class. The population was the tenth grade students of SMAN 1 Abung Semuli Kotabumi-North Lampung, while the research sample was the tenth Science 5 (X Science 5) class consisting of 32 students. A reading test was used as the research instrument to measure the students' reading comprehension. Based on the data analysis, it is found that gender and culturally familiar texts have significant influence on students' reading comprehension in which the t-test analysis by SPSS computer program shows that the significant value (sig) is less than the α (0,05). Referring to the research result, it is important that the English teachers apply a reading material which covers both male and female interest and enable the students activate their prior knowledge through the culturally familiar reading material.

Keywords: *gender, gender based-material, cultural familiarity, reading comprehension, schemata*

I. INTRODUCTION

Reading seems to be the fundamental skill that will determine the students' success in their learning process. It is fundamental skill because the students' success in comprehending or grasping meaning from what they read will give them new information which enlarge their knowledge. When students fail to grasp suitable meaning either explicitly or implicitly stated on what they read, it will cause them misunderstand the messages throughout the text they read. Therefore, comprehension becomes a very important objective or goal in a reading process. All the reading activities designed in the classroom interactions are focused to teach the students in order to achieve good comprehension in reading. Furthermore, the process of comprehending a reading material is affected and determined by many aspects either from the readers' variable or the text's variable as well as the external factors such as environment. Likewise, in comprehending a reading material, readers will involve more than just the vocabulary, tenses, and the text

structure constructing the reading text. Koban (2016:218) and Al-Khataybeh & Al Masri (2008) agreed that comprehending a reading text also needs the readers' variety of skills like the ability to identify the explicit and implicit information from the text, the ability to determine the text organization, the ability to respond critically to the text, as well as the ability to make inference throughout the content besides the readers' knowledge about vocabulary, grammar, text structure and the text genre. Additionally, according to Cook in Shahmohammadi (2011:11), reading comprehension not only involve with the language constructed the text, but it also involves with what the readers have previously known or usually called as prior knowledge. In this case, students' prior knowledge will help them understand new information they read when the reading materials contain such context in which it fits into what they already known.

Goodman and Smith in Grabe in Shirzadi (2015:25) also pointed out that "reading is not a process of recognition of letters and words one by one but good readers use their background knowledge and prediction so reading would be a "selective process" and it could be different from one reader to the other." In other words, this theory explains that in order to comprehend a reading material students need to activate both their background knowledge and their linguistics knowledge in which it strengthens that students' background knowledge (prior knowledge) is an important aspect in reading comprehension process. The background knowledge of the students is theoretically explained in schemata theory. The theory is closely associated with how readers combine their previous knowledge with the text. It is explained in Martinez (2014:70):

"Schema theory is based on the idea originally suggested by Bartlett (1932) that human memory consists of high level structures known as schemas, each of which encapsulates our knowledge about everything connected with a particular object or event. These schemas represent the general knowledge which aids the understanding of conversations and texts, as well as real-life events. A schema theory is a theory about how knowledge is represented and about how that representation facilitates the use of the knowledge in particular ways. The knowledge stored in schemata interferes with the interpretation of new information (Carrell, 1991). If new information is incomplete, the reader makes inferences on the basis of the selected schema in order to fill in the missing parts."

Furthermore, Abu Rabia in Liu (2015:71) stated that the students' activated background knowledge or schemata when reading will be determined by the students' experiences. The more experience they have, the more types of schemata they stored in their mind that will be active during the process of reading. In line with Abu Rabia, Harmer in Alkelani (2017:83) illustrated that the students' schemata refers to their personal experience accumulation. In regard with this theory, it is then clear why theoretically it is stated that the schemata of male and female students are different. Male and female students experience more in different life contexts in which male students might have more experience with male-oriented text, activity, situation, etc as well as female students tend to have more experience with such text, activity, situation that refers to female-oriented context. This situation then results to different performance in comprehending gender based or gender oriented text. Male-students should be better in comprehending a male-

oriented text and vice versa because during the process of reading their brain will organize what is being read with their schemata. As a consequence, both male and female students will be easier and comprehend better a gender-oriented text which is relevant with their gender because what is being read suits with what they much experience in their real life. In fact, several previous studies conducted about gender differences in reading comprehension reveal different findings and conclusions due to the theoretical concept about male and female schemata. Martinez (2014), Salehi, Lari, and Rezanejad (2014), Alkelani & Habil (2017), Asgarabadi, Rouhi, & Jafarigohar (2015), Shirzadi (2015) and Koban (2016) investigated about gender differences on reading comprehension resulted that there is no significant relation between gender differences and their reading comprehension. The studies found that male and female students represent different performance in reading comprehension regardless with their gender.

On the other hand, The other study conducted by Sotoudehnama & Asadian (2011) resulted different finding in which gender differences significantly affect students' reading performance. The research finding reveals that male-students perform better in comprehending a male-oriented text, while female-students also perform better in comprehending a female-oriented text. This research result seems to be relevant with schemata theory. Meanwhile, Anantasa (2016) conducted a case study to investigate how might gender differences contribute to students' reading comprehension. Referring to the research finding, it is found that female-students perform better in reading comprehension in regard with different trait of their family and society toward reading. In this case, it is found that the role of several factors such family, environment, motivation, topic etc., will be essential factors that contribute to both male and female students attitude in reading which then influence their reading comprehension. Likewise, this research finding also support the existing theories which state that female performs better in reading than boy because biologically there is different structure of brain between male and female in which female's hemisphere is claimed to be thicker than male's resulted female's reading comprehension performance is better than male's.

In the context of cultural familiarity and schemata theory, Abu-Rabia (1996), Bensoussan (1998), and Shirzadi (2015) in their study about the effect of cultural familiarity on students' reading comprehension have found that students comprehend a culturally familiar material better than a culturally unfamiliar material. In other words, this research result reveals that cultural familiarity affects students' reading comprehension. Additionally, This finding strengthens the opinion that language curricula are easier to comprehend when the contents are relevant to the readers' lives and cultural backgrounds. Another previous research also conducted by Gurkan (2012) who investigated "The Effects of Cultural Familiarity and Reading Activities on L2 Reading Comprehension" found that cultural familiarity gives significant effect on L2 Reading comprehension. In his research, he relates his research finding with the theory of interest in a language classroom in which promoting students' interest will increase their intrinsic motivation during the learning process. It is explained that students' situational interest will increase when reading a material contains culturally familiar words and expression that might help them to achieve a better comprehension.

With regard the previous studies revealing the fact that cultural familiarity affects students' reading comprehension, Kurnaz (2016:41) mentioned two scientific analysis of what might make culturally familiar material help the language learners to achieve a better comprehension, they are: First, an unfamiliar material will provoke to the students' curiosity which might be able to lead the students to be more enthusiastic in learning new vocabulary; Second, though the unfamiliar material will provoke the students' curiosity, a familiar material that is easier to understand is always more beneficial for the students' comprehension. Furthermore, due to the previous researches about gender differences, cultural familiarity, and reading comprehension which reveal various results in which some are relevant with schemata theory of male and female students, some others seem to reject it, and some of the rest show that both gender will have different performance in reading comprehension due to the effect of other factors such the reading topic that determines their reading attitude, their family support, their environment, and so on, it is concluded that comprehension is not only affected by the reader's variable, but also affected by the text variable. Therefore, it is necessary that teachers presented the relevant reading material which suits the students' need and interest.

In that case, this research is done under the concept of schemata theory and the principle of gender sensitive material in a reading activity. Very first of all, a reading material based gender and cultural familiarity was constructed under the research and development project. Then, it was implemented in order to investigate the effectiveness of the reading material constructed toward the students' reading comprehension. The research findings are hoped to be beneficial for the English teacher especially and generally for reading teacher in order to take into consideration many aspects such gender and cultural familiarity to construct or choose a reading material which will be implemented in the classroom reading activities.

II. METHODS

This research is under the project of Research and Development design in which the research is started by designing a prototype, then apply it to the research sample under the experimental research design. In applying the prototype, a one-group pretest-posttest design was used in order to investigate the influence of using a reading material based gender and cultural familiarity toward the students' reading comprehension. The sample was the X IPA 5 students of SMAN 1 Abung Semuli taken purposively in considerations with the research needs. The instrument used to collect the data in order to determine the effectiveness of the prototype was a reading comprehension test. Having collected the data, it was then calculated to test the research hypotheses using parametric statistics. Therefore, the data analysis was started by calculating the normality and homogeneity of the data. Finally, it was analyzed by using independent t-test analysis to test the research hypothesis.

III. RESULTS AND DISCUSSION

The research and development project has resulted a reading material based gender and cultural familiarity which is constructed under the principles of a gender neutral and culturally familiar text. The researcher has developed a reading material for the tenth

graders which is developed from the basic competences of the even semester in curriculum. The reading material consists of eight chapters as follows:

- Unit 1 : Expressing Introduction
- Unit 2 : Congratulating & Complimenting
- Unit 3 : Future Plan
- Unit 4 : Descriptive Text
- Unit 5 : Announcement Text
- Unit 6 : Simple Past Tense & Present Perfect Tense
- Unit 7 : Recount Text
- Unit 8 : Narrative Text

Each of the chapters is developed on the basis of reading comprehension material construction principles in which it consists of several tasks which cover the aspect of reading comprehension such vocabulary building, identifying the language feature and text structure, identifying the information from the text, and some other activities that are suit the basic competence to be achieved. One example of the reading material is presented in the following picture.

Read the following dialogue!



Source: <https://www.kaskus.co.id/thread/59a3708edbd770ac468b4567/5-aliran-pencak-silat-yang-paling-disegani/>
Picture 2.1

- Dea: Hi, Alya, Aris, I heard from Ms. Susi that you two won the pencak silat match in Jakarta yesterday. congratulations to you. You know, it's good work, friend! You two are great!
- Alya: Thanks Dea. We really didn't expect before that we would finally win this match. Right Aris?

Figure 1 An example of reading material based gender and cultural familiarity

The material above completed with a picture of two students performing an action in *Pencak Silat* competition. First, the use of both gender presented on the pictures show the gender equality in doing certain action. The picture shows that both male and female students can take participation and do the same in Pencak Silat competition. It has eliminated the gender stereotype such only boys can join this athletic sport. In this case,

this reading material has been constructed under the principle of gender-neutral material meaning that by presenting the gender equality both male and female students will be more interested in this reading material. Second, the use of Pencak Silat as a topic is in relation with the students culture in which Pencak Silat belongs to one of Indonesian culture and it is culturally familiar in Indonesian society. As it is mentioned that there are three types of culturally content in literary materials: target language culture, local culture, and international culture. Target language culture meaning that the literary texts contain such term, vocabulary, context, situation, etc which be the culture of the language learned (in this case is English); local culture relates with the local culture of the learners (in this case Indonesian) that nationally popular in Indonesia; International culture refers to the culture of various countries in the world except the country of the target language from.

Having finished constructed the reading material, it was then validated by several experts to see whether it is appropriate or not to be used as a reading material at school. The validation process run for several times with revision session on the basis of the validator's criticism and suggestion. Then, after the reading material met the appropriateness standard to be implemented, it was then implemented under the experimental research design. Treatment was done by teaching the students using the reading material for several meetings. However, a pretest was firstly conducted before the treatment was done. In the end of the research session, a posttest was given to measure their reading comprehension after being taught by reading material based gender and cultural familiarity. The result of the pretest and posttest is presented as follows:

Table 1 Interval Score of Pretest

No	Interval Class	Frequency	Percentage (%)
1	10--20	3	9,375
2	21--31	5	15,625
3	32--42	2	6,25
4	43--53	7	21,875
5	54--64	6	18,75
6	65--75	9	28,125
Total		32	100

Table 2 Interval score of Posttest

No	Interval Class	Frequency	Percentage (%)
1	15--27	1	3,125
2	28--40	4	12,5
3	41--53	4	12,5
4	54--66	11	34,375
5	67--79	7	21,875
6	80--92	5	15,625

Total	32	100
--------------	-----------	------------

From the data of the pretest-posttest, it was then analyzed to find out the descriptive statistics of the data which is presented in the following table:

Table 3 Descriptive Statistics of the Pretest-Posttest Data

	Pretest	Posttest
N	Valid	32
	Missing	0
Mean	48,91	60,78
Median	50,00	60,00
Mode	45	60
Std. Deviation	18,216	17,418
Variance	331,830	303,402
Skewness	-,363	-,447
Std. Error of Skewness	,414	,414
Range	65	75
Minimum	10	15
Maximum	75	90
Sum	1565	1945

From the data, it is known that students' mean score increases from 48,91 in pretest to 60,78 in posttest. Beside that, it is also found that there is an increase on the minimum and maximum scores achieved in pretest and posttest. The minimum score increases from 10 to 15, and the maximum score increases from 75 to 90 in posttest. This research findings seem to notice that the implementation of reading material based gender and cultural familiarity significantly influences students' reading comprehension. Therefore, it is necessary to conduct a further statistical analysis in order to prove it. A statistical analysis to test the mean score difference between two classes was done by using t-test formula. In this case, because t-test is a statistical parametric analysis, it is necessary to conduct a prerequisite test firstly before the t-test as a requirement in analyzing a research data using statistical parametric formula. The prerequisite test consisted of normality and homogeneity test as the results are presented clearly as follows:

Table 4 Normality Test of the Data

	Kolmogorov-Smirnov ^a			Shapiro-Wilk		
	Statistic	Df	Sig.	Statistic	df	Sig.
Pretest	,135	32	,146	,950	32	,141
Posttest	,112	32	,200*	,972	32	,542

*. This is a lower bound of the true significance.

a. Lilliefors Significance Correction

It is known from the table that the significant value of both pretest and posttest data (0,146 & 0,200) are greater than the value of α (0,05), so it is concluded that the research data are normally distributed. Next, having found that the data are normally distributed, it is continued by conducting a homogeneity test in which the result is as follows:

Table 5. Homogeneity of the Data

Levene Statistic	df1	df2	Sig.
,516	1	62	,475

The value of significant in homogeneity test is 0,516 which is greater than the value of α (0,05). As a result, the data of pretest and posttest are homogeny. As consequences, the t-test analysis is allowed to conduct to examine the influence of gender based material and cultural familiarity toward students' reading comprehension. The result of t-test analysis is presented in the following table:

Table 6. t-test Analysis Result

		t-test for Equality of Means						
		t	df	Sig. (2-tailed)	Mean Difference	Std. Error Difference	95% Confidence Interval of the Difference	
						Lower	Upper	
Skor	Equal variances assumed	-2,665	62	,010	-11,875	4,455	-20,781	-2,969
	Equal variances not assumed	-2,665	61,876	,010	-11,875	4,455	-20,782	-2,968

The table informs that the value of significant (0,10) which is greater than the value of α (0,05). As the result, it can be concluded that there is significant influence of reading material based gender and cultural familiarity toward students' reading comprehension. This research finding supports the previous research conducted by Martinez (2014) which resulted that gender and content familiarity significantly affect students' overall reading comprehension of the texts. Additionally, the research finding also relevant with the schemata theory. The reading material which is constructed under the gender-neutral principles and contains culturally familiar vocabulary, terms, life context, etc., made the students easier in the process of comprehending the material which finally affect their reading comprehension achievement.

Several theoretical explanations can be discussed with regard the research findings in this study. First, the reading material which is constructed under considerations about the male and female' interest is proved to be successfully attracted both male and female-students' interest in working on the texts during the reading comprehension process. This is then correlates with the theory of interest in learning. A relevant material with the students' need will be more interesting for the students. When students' interest raises they will reflect positive attitude toward reading such applying certain strategy in order to grasp the meaning from the text. This is what might then help them perform better comprehension. Besides interest, the research finding also correlates with the content of

the reading material which is familiar for the students. In this research, every reading material entails familiar vocabulary, terms, life context, names, places, etc., which are culturally familiar and fit into the students' prior knowledge. As consequences, it is easier to understand and affect students' comprehension performance.

IV. CONCLUSIONS AND SUGGESTIONS

The research finding is that there is significant influence of reading material based gender and cultural familiarity toward students' reading comprehension. It is then concluded that gender is one of the reader's variable in reading which affect students' comprehension depend on the content of the text, the students' environment, family supports, and other variables that will contribute to the process of comprehending reading text. Meanwhile, cultural familiarity is one of the aspects of the text variables. Altogether, gender and cultural familiarity connect the readers with the pre-existent knowledge that is stored in their schemata.

Referring to the conclusion, it is suggested for those who teach reading skill in order to take into consideration reader's variables such gender, age, background, etc., and text 's variables such cultural familiarity, content familiarity, text types, etc., in selecting and applying the reading material in a reading class. When possible, it is suggested that teachers or practitioners in education conducting further research to evaluate or examine the reading material applied at schools. Especially, it is important to examine whether the reading materials applied have been constructed under the basis of gender-sensitive principles.

Funding

This research is funded by Direktorat Riset dan Pengabdian Masyarakat Direktorat Jendral Penguatan dan Pengembangan Kementerian Riset, Teknologi, dan Pendidikan Tinggi sesuai dengan Kontrak Penelitian Tahun Anggaran 2018

REFERENCES

- Abu-Rabia, S. (1996). Factors affecting the learning of English as a second language in Israel. *The Journal of Social Psychology*, 136(5), 589-595.
- Al-Khataybeh, M., & Al-Masri, A. A. (2008). The readability level of English textbooks of the tenth grade and its relationship to students' gender and area of residence. *European Journal of Social Sciences*, 6(3), 368-374.
- Alkelani, Waseem. & Habil, Hadina. (2017). The Influence of Content Familiarity, Gender Difference and Proficiency Level on Reading Comprehension Performance: A Study on Malaysian Undergraduate Students in UPM. *LSP International Journal*, Vol. 4(1), 81–100.
- Anantasa, Jefi Fauzan. (2016). Gender Differences In Reading Comprehension Achievement (A Case Study At Iain Syekh Nurjati Cirebon). *ELT-Echo*, Vol. 1 (1), 28—41.
- Asgarabadi, Yadollah Hosseini. Rouhi, Afsar. Jafarigohar, Manouchehr. (2015). Learners' Gender, Reading Comprehension, and Reading Strategies in Descriptive and Narrative Macro-genres. *Theory and Practice in Language Studies*, Vol. 5(12), 2557-2564.

- Bensoussan, M. (1998). Schema effects in EFL reading comprehension. *Journal of research in reading*, 21, 213-227.
- Gurkan, Serkan., (2012). The Effects of Cultural Familiarity and Reading Activities on L2 Reading Comprehension. *Procedia - Social and Behavioral Sciences*, 55 (2012) 1196 – 1206.
- Koban Koç, D. (2016). The role of gender in reading comprehension: An analysis of college-level EFL students' comprehension of different genres. *International Online Journal of Education and Teaching (IOJET)*, 3(3). 218-227.
- Kurnaz, Yirdilay. (2016). Cultural Familiarity in Vocabulary Learning through Literary Texts: Short Story Reading. *Journal of Narrative and Language Studies*, Volume 4(7), 40—49.
- Liu, Yi-Chun. (2015). The Perception of Cultural Familiarity and Background Knowledge on Reading Comprehension for Intermediate EFL Students. *International Journal of Language and Literature*, Vol. 3 (1), 71—75
- Martinez, Ana Cristina Lahuerta. (2014). Analysis of the Effect of Content Familiarity and Gender on English as a Foreign Language Reading Comprehension by Spanish University Students. *Porta Linguarum*. Vol. 21, 69—84.
- Salehi, Mohammad., Lari, Zahra., & Rezanejad, Atefeh. 2014. The Effects of Gender and Genre on Language Learners' Reading Comprehension Ability. *Education Journal*. Vol. 3, No.5, pp. 266-271.
- Shahmohammadi, Nayereh. (2011). The Effect of Gender Base Materials on Reading Comprehension. *International Journal of Human Resource*. Vol 1, Nomor 2.
- Shirzadi, Dania. (2015). The Effects Of Cultural Knowledge On Iranian EFL Students' Reading Comprehension Across Male And Female Learners. *Journal of Languages and Culture*, Vol 6(4), 24—29.
- Sotoudehnama, E., Asadian, M. (2011). Effect of Gender – Oriented Content Familiarity and Test Type on Reading Comprehension. *The Journal of Teaching Language Skills (JTLS)* 3(2), 156—178.

About the Authors

Author 1

Complete Name : Elis Susanti
Institution : STKIP Muhammadiyah Kotabumi
Email Address : weasley.ndha@yahoo.com
Education : English Education
Research Interest : English Language Skills, Affective facets, etc

Author 2

Complete Name : Rini Susilowati
Institution : STKIP Muhammadiyah Kotabumi
Email Address : rini.ariyanto12@gmail.com
Education : English Education
Research Interest : English Language Skills, Linguistics

Author 3

Complete Name : Asep Hardiyanto
Institution : STKIP Muhammadiyah Kotabumi
Email Address : asephardian005@gmail.com
Education : English Education
Research Interest : English Language Skills, Linguistics

COLLABORATIVE BLENDED LEARNING ACTIVITIES TO IMPROVE EXTROVERT AND INTROVERT STUDENTS' ARGUMENTATIVE ESSAY WRITING ABILITY AND THEIR PERCEPTION

Ani Novitasari¹, Patuan Raja², Flora³
University of Lampung, Indonesia^{1,2,3}
aninosaheri@gmail.com¹

ABSTRACT

Nowadays, technology has been used massively included in education field in university context, so the learning process is done both in classroom (offline) and out of the class via online media like WhatsApp, as one of the technology results. This research investigated whether there is different increase of argumentative essay writing ability between extrovert and introvert students after they were taught by using Collaborative Blended Learning (CBL), and studied their perceptions towards CBL. This study applied pretest-posttest experimental group design. There was a class as the sample chosen randomly among 8 English education classes at UIN Raden Intan Lampung. It was consisted of 28 students (7 extroverts and 21 introverts). To collect the data, argumentative essay writing test, questionnaire of personality given before CBL, and questionnaire of perception given after the treatment were employed. Data from the test were analyzed with independent sample t-test resulting significance value that was higher than Sig level ($0.312 > 0.05$) meaning that there is no different increase of argumentative essay writing ability between extrovert and introvert students after they were taught by using Collaborative Blended Learning (CBL). Furthermore, data from the perception questionnaire were analyzed with descriptive statistic resulting that both extrovert and introvert students perceived positively towards CBL in writing argumentative essay. Hence, CBL is preferable to use and can increase both extrovert and introvert students' argumentative essay writing ability.

Keywords: *collaborative blended learning, argumentative essay writing ability, perception, extrovert, introvert*

I. INTRODUCTION

Students in English department wish to make their own good things in the cultural, literary and aesthetic life of English-speaking countries (Broughton, 1980). Moreover, Ulum (2015) states that in university settings, those candidate teachers are trained on the base of EAP (English for Academic Purpose) in which programs are situated on language skills needed to perform in the academic context of core subject areas involving vocabulary, grammar and language skills based teaching covering listening, speaking, reading, and writing. In other words, those ELT (English Language Teaching) students need support in developing their language skills, so they become more competent in their subject specific courses. It is included in writing subject as English skill also which is valuable for academic purpose (Ellis in Madkour, 2016).

However, majority of entry-level English majors do not have extensive experience in writing (Jozsef, 2001). In this case, for having meaningful and applicable writing, we have to know its special conventions such as punctuation, paragraph constructions and so on (Harmer, 2001). Moreover, writing requires different kinds of ability depending on the type of writing that is being engaged in (McKay, 2008). For instance, the writer needs to have ability to commit to paper thoughts, ideas, and opinions that seek expression (Jozsef, 2001). Furthermore, even for learning how to write in non-native language, it is quite difficult as Nezakatgoo (2010) states that writing is the most difficult skill for foreign learners to be mastered. They have to pay much attention to higher level skills such as planning, organization as well as lower level skills such as spelling, punctuation, diction, and so on. Therefore, Ghufroon et.al, (2016) state that students need to be taught how to write academic writing.

Furthermore, most academic courses in English-medium colleges and universities use essay writing to assess students' work (Bailey, 2004). Writing an essay is to persuade an educated and critical reader that our point of view on a topic is correct (McClain and Roth, 1999). In addition, essays are various based on the purpose of writing. One of them is argumentative essay which is one of the most common forms of text that undergraduate students write to fulfill their course requirements in a writing course (Alarcon and Morales, 2011), included by State Islamic University of Raden Intan Lampung based on the curriculum applied. In this case, the writer should give his or her opinion that can be supposed by evidence such as facts (Smalley and Ruetten, 2005), and the writers should attempt to support a controversial point or defend a position on which there is a difference of opinion (Richard and Schmidt, 2002). Thus, university students should give their arguments toward such a thing with some proofs of their critical thinking as high level academicians.

Nevertheless, Bahaziq (2016) in his study states that students' essay writing ability needs to be improved. Also, it is in line with the recommendation from Azizollah et. al, (2013) that English practitioners should introduce, and be introduced to the specific techniques and materials that facilitate the enhancement learners' critical thinking abilities in writing argumentative essay.

Recently approaches to language teaching have been developed from what we know from traditional to the more recent learning approaches. Face-to-face learning which we call as traditional approach, which teaching and learning process happens in classroom, has been collaborated with the use of information and communication technologies worldwide nowadays (Thorne: 2003; Dziuban, et. al., 2004; Cabero, et. al, 2010; López-Pérez, et. al, 2011; Shahrokni and Talaeizadeh, 2013; Yang, et. al., 2013). Furthermore, nowadays, in Indonesia, the use of information and technology should be considered in teaching learning process as in Indonesia law number 20 year 2003 chapter X article 36 verse 3 (Indonesia government: 2003). In this case, the combination of both (blended learning) has given positive or useful impact of learning outcomes of the students (Hamad: 2015; Syafi'i: 2016; Ferriman: 2013; Maulan and Ibrahim: 2012). Furthermore, through blended learning,

students represent a real opportunity to create learning experiences at their right time and in the right place integrated with the innovative and technological advances (Thorne: 2003; Syafi'i: 2016; Hubackova, et. al.,: 2011). Therefore, learners can be involved in blended learning with some freedoms of exploring their potentials, time and place both in classroom and through online media as technology result.

Besides, the findings of research by Matzat (2013) show beneficial effects of blended learning in communities. In this case, students learned in community collaboratively. Moreover, according to Uribe, et. al, in Ferriman (2013), in using technology for students' learning at campus, it is better if educator makes students learn collaboratively than individually. In addition, Snodin (2013) finds that the most outstanding advantage of the blended learning is that it helps to facilitate collaborative learning. Thus, collaborative blended learning seems suitable for students to learn more in group collaboratively via technology besides just in the classroom.

Syafi'i (2016) found that blended learning is one of the advocated ways to enhance the vocational students' motivation and English achievement in writing simple messages. Moreover, Maulan and Ibrahim (2012) studied the use of blended learning collaborating students to discuss in group (collaborative blended learning) in writing expository genre in a university. Nevertheless, there have not been available studies about collaborative blended learning in writing argumentative essay by university students in Indonesia.

According to Bath and Bourke (2010), discussion board is one of very suitable tools or social media that can be used in collaborative blended learning and has multiple forums and can involve different groups of users. One of discussion board examples is WhatsApp. This application is used in many frequencies (Seufert, et.al., 2016). We can easily send enough unrestricted messages to our Whatsapp friends, and it is suggested that WhatsApp can be used as learning media (Shanmugapriya and Priya, 2016). As what we have known about collaborative blended learning to learn writing especially in writing argumentative essay, WhatsApp can be used by university students, for it will give more freedom for the students to think critically about their arguments through discussion.

Zayed (2016) conducted research to intermediate level about special designed activities which were most about vocabulary mastery for learning English language through the application of WhatsApp. From the finding, he suggested the use of WhatsApp for other levels, and the created group on the WhatsApp between the teacher and the students. Moreover, not only teacher-students interaction, as applied by Rambe and Chipunza (2013), WhatsApp was applied also by interaction among peers of fourth year students. Also, their finding shows that campus students enjoyed positive freedom manifested through relatively equal access to networks notwithstanding variations in networked access beyond campus after hours through this medium. In addition, Andújar-vaca and Cruz-Martínez (2017) conducted research by creating a "WhatsApp" group where 40 of the students participated in a daily interaction during six months. The aim was to measure the students' degree of oral

development and the type and triggers. Also, Awada (2016) has ever studied on effect of WhatsApp on critique writing proficiency through writing argumentative synthesis essay and a writing critique, and perceptions toward learning of English as a foreign language. However, the use of WhatsApp in collaborative blended learning discussing argumentative essay writing to university students in the context of Indonesian learners has not been studied yet, included in State Islamic University of Raden Intan Lampung in which English is as a foreign language.

The following was procedure done about writing process for writing product (argumentative essay writing) based on the Harmer's model (2007); planning, drafting, editing (reflecting and revising), and final version, and about blended learning from Challob et. al, (2016).

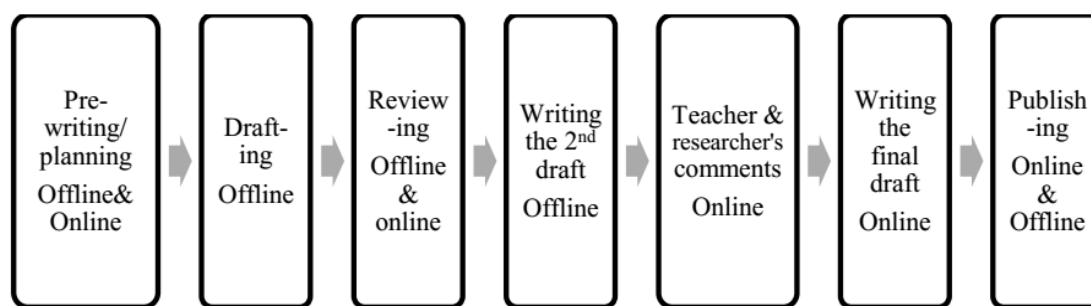

Figure 1. Modified Procedures of Collaborative Blended Learning

In addition, the study from Syafi'i (2016) suggests that personal consultation about how they get through blended learning is a necessary point that should be taken into account. It is due to that in fact, we know that not all students like learning face to-face (offline) and not all too like online learning. Students' writing motivation increased considerably through online learning (>86% toward positive attitudes) according to Purwanto (2016). Meanwhile, there are introversion people who prefer written form of communication (Hirsh and Kise: 2006) out of extroversion people who prefer face-to-face (offline) communication. To know whether extroversion students really enjoy writing through technology of social media (online), and whether introversion students are able to produce writing product better than the extrovert, in this case aspect of personality is also important to analyze whether it affects students' writing process and product or not.

This study was different from Awada's treatment (2016) asking the students to write collaboratively only in a class group included for the WhatsApp group (25 experimental sample). In this study, the researcher grouped the students into some smaller groups, and that was based on their personality. In this case, Harmer (2002) states that if we see that some students participate less than others, we might make a group of weak participators, so they will find it less easy to hide behind their more talk active colleagues, and we can also make groups of especially talk active students too. Hence, this research treatment grouped students of extrovert with extroverts and introvert with introverts (homogenous).

Furthermore, the researcher conducted research by considering personality of students in order to know their perceptions towards collaborative blended learning in writing argumentative essay through both offline learning and the use of WhatsApp. In this case, perception can be defined as experience of an object, event or relationship that is acquired by concluding information and interpret message (Harsasi, et.al., 2008). Hence, the researcher would like to know how both extrovert and introvert students who are, as we know, different psychologically each other in concluding and interpreting about themselves and the use of collaborative blended learning in writing argumentative essay through both offline learning and the use of WhatsApp.

Based on background of the problem explained above, the problems of this study are formulated as follows:

1. Is there any different increase of argumentative essay writing ability between extrovert and introvert students after being taught by using Collaborative Blended Learning?
2. How is extrovert and introvert students' perception towards Collaborative Blended Learning in writing argumentative essay?

II. METHODS

This research was an experimental study with pretest-posttest one-class group taught by using Collaborative Blended Learning (CBL) for the treatment. The population of this study was the fourth semester students of English Study Program in State Islamic University of Lampung in the academic year of 2017/2018 who took Academic Writing Course. The sample was chosen randomly, so it was gotten that E Class (often called PBI 4E) was chosen as sample of experimental group consisted of 33 students who were 7 of them were extroverts, 21 were introverts, and 5 were ambiverts (not included in analysis of this research).

The instruments used were argumentative essay writing test with scoring system proposed by Schaefer (2008), and questionnaires of 28 items with Likert scale of students' personality traits adopted from Andriani (2015) and 25 closed-ended questions with Likert scale and one open-ended question of students' perception toward collaborative blended learning with the use of WhatsApp that was developed by the researcher from some experts' theory such as by Harmer (2007) related to writing process and by Fung and Mei (2005), also theory of perception from López-Pérez, et al. (2011) about utility, motivation and satisfaction, with the consideration of the application of Collaborative Blended Learning (CBL).

To get content validity, the writing test was suited with the material taught to the students. Moreover, to know the reliability of the argumentative essay writing ability test, two raters scored students' essays (the researcher and a writing academic lecturer of English Education in UIN Lampung). In addition, the questionnaire of personality trait was tried out to non-sample students in order to know the validity and reliability of the instrument that was given to find out whether the student's personality was extrovert or introvert. The r result was

compared with r table with significance 0.05 ($df = 27 - 2 = 25$), and that is 0.323. Here is the result of the item validity from each item with the total number of 28 items before the questionnaire was validated became 24 items. After the items of personality trait questionnaire became 24 items after validated, then, the result of personality trait questionnaire reliability test showed the Alpha 0.986, so it came into reliable data because it was higher than 0.06. Moreover, the result of students' perception towards CBL in writing argumentative essay showed the Alpha 0.735.

The different increase of argumentative essay writing ability between extrovert and introvert students after being taught by using Collaborative Blended Learning was known by analyzing their argumentative essay writing test obtained from pre-test and post-test. The data obtained were analyzed by computing them in SPSS 16 program. Independent group t-test was used to compare mean of two different groups (Setiyadi, 2006). Then, the result was compared by using t-test with significant level (α) 0.05 to find out whether the different increase was significant or not. To be able to use t test formula to analyze the data answering research question 1 and 2, the researcher fulfilled the following three basic assumptions of data that were: 1) interval; 2) from random sampling of the population; and 3) in normal distribution (Setiyadi, 2006). Moreover, descriptive statistic was used to analyze the data from closed-ended questions of perception questionnaire. The data were drawn with tables and diagrams to explain each item of the questionnaire. Moreover, related to qualitative data gotten from open-ended question, the researcher followed data analysis from Miles and Huberman (1994). The researcher collected and selected the data to know which data could be used or not. Then, the researcher analyzed the data and finally gave the conclusion.

III. RESULTS AND DISCUSSIONS

After conducting the treatment to the students, the researcher got the results to answer the research questions.

Result of RQ 1: Is there any different increase of argumentative essay writing ability between extrovert and introvert students after being taught by using Collaborative Blended Learning?

The following is the table showing the increase of extrovert and introvert students' based on the pre-test and post-test means.

Table 1. The increase of the extrovert and introvert students' argumentative essay writing ability scores in general

Personality	Pre-test mean	Post-test mean	Increase	Percentage (%)
Extrovert	62	76	14	14%
Introvert	54	73	19	19%

The table above shows that the increase of the mean scores in the experimental group for the extrovert students based on the inter-rater calculation is 14 or 14% on average. Moreover the

increase of the mean scores in the experimental group for the introvert students based on the inter-rater calculation is 19 or 19% on average. It clearly indicates that after having the treatments through blended learning, students of both personalities got better argumentative essay writing ability.

To make sure whether there is significant different between extrovert and introvert students' argumentative essay writing ability, to answer the research question 1, the researcher used independent sample t test through SPSS. The hypotheses are as follows.

- a. Ho: There is no different increase of argumentative essay writing ability between extrovert and introvert students after being taught by using Collaborative Blended Learning.
- b. Ha: There is different increase of argumentative essay writing ability between extrovert and introvert students after being taught by using Collaborative Blended Learning.

The following table shows the result to answer the hypotheses.

Table 2. The result of independent t-test of the research question 1

	Levene's Test for Equality of Variances	t-test for Equality of Means								
		F	Sig.	t	Df	Sig. (2-tailed)	Mean Difference	Std. Error Difference	95% Confidence Interval of the Difference	
									Lower	Upper
GainPrePost	Equal variances assumed	.168	.685	-1.030	26	.312	-5.762	5.593	-17.259	5.735
	Equal variances not assumed			-1.224	14.660	.240	-5.762	4.708	-15.816	4.292

The table above shows the t-critical was 0.312 which was higher than the significance level 0.05 ($0.312 > 0.05$). It indicates that zero hypothesis (Ho) was accepted. It means that there is no different increase of argumentative essay writing ability between extrovert and introvert students after being taught by using Collaborative Blended Learning. The extrovert students' argumentative essay writing ability did not differ significantly from the introvert ones after both of them were taught by using CBL. In this study, the difference was relative because, however, the increase percentage of introvert students was higher than the extrovert ones.

This finding is congruent with the previous studies of Ahour and Haradasht (2014) explaining that there was no different increase between the two personality groups in the cooperative situation as seen in the collaborative learning in CBL. Moreover, the study from Gholami, et.al., (2015) also shows that both personalities performed with no different

increase regarding to different task based activities included opinion-gap activities in which the students were asked to give their opinion as well as applied in this research using CBL in writing argumentative essay in which the students were also asked to give their strong point of view related to the hottest issue happened. In addition, Gholami, et.al., (2015) also stated that psychologically extroverts and introverts were different and behaved according to their traits; however, in language learning, more detailed researches, such as this research, were needed, for we know that the result could show that the difference result of learning could be not different as in this research result.

For English as Second Language (ESL), Zafar (2017) stated that extroversion is a positive trait for learning language. However, specifically for writing skill, he said that this skill did not correlate strongly with either of the personality traits of extrovert and introvert. Writing proficiency scores among them showed very little variation. Thus, this research conducted for English as a Foreign Language (EFL) resulted the same finding with Zafar's.

This finding is congruent with Pourqardash and Soori's statement (2017) that introvert students were better on recalling of learned knowledge. They would do better at developing cognitive academic language proficiency. Moreover, in the context of writing skill, as stated by Hirsh and Kise (2006), introvert people tended to prefer written form of communication. Hence, it could be the reason that their increase in writing essay was higher the extrovert ones who preferred to communicate verbally. Furthermore, McCrae and Costa (2006) stated that introverts read books, and intelligent introverts read difficult book. In this case, this indicated that they could write after being supported by what they had read, and as university students, they exactly read or looked for the better sources to support their thought in their argumentative essay related to this study.

However, it doesn't mean that extrovert students did not study at all while they were getting the treatment of CBL during writing argumentative essay, for their argumentative essays also increased, as stated before. In writing argumentative essay through CBL, the students learned not only by non-stop drafting but also all stages of writing as conducted in this study based on Harmer (2007): planning, drafting, editing and publishing. In those stages, the students learned not only in the classroom but also via WhatsApp, and they studied collaboratively. All these things were supported by Hirsh and Kise (2006) who state that the extrovert students usually have a great tendency to be engaged in group activities, sociability and interaction. Moreover, eventhough extroverts seemed protest towards writing task (Hirsh and Kise, 2006), it had been found that they easily communicate in English classes, so they would succeed (Suliman, 2015). Oxford in Zafar (2017) stated that they would communicate what they need to know better, especially in face-to-face communication, so they could improve their writing through communication either in the classroom or via WhatsApp as in this study. Hence, all the argumentative essay writing stages above were passed by the extrovert students collaboratively well because they liked to communicate.

Therefore, the increase of argumentative essay writing ability between extrovert and introvert students after being taught by using Collaborative Blended Learning was not different significantly or just different relatively. Both personalities are potential to learn writing argumentative essay through Collaborative Blended Learning and improve their skill on it.

Result of RQ 2: How is extrovert and introvert students’ perception towards Collaborative Blended Learning in writing argumentative essay?

Extrovert students’ perception

Based on the data gotten from the perception questionnaire given to extrovert students, we got the following data drawn in the table.

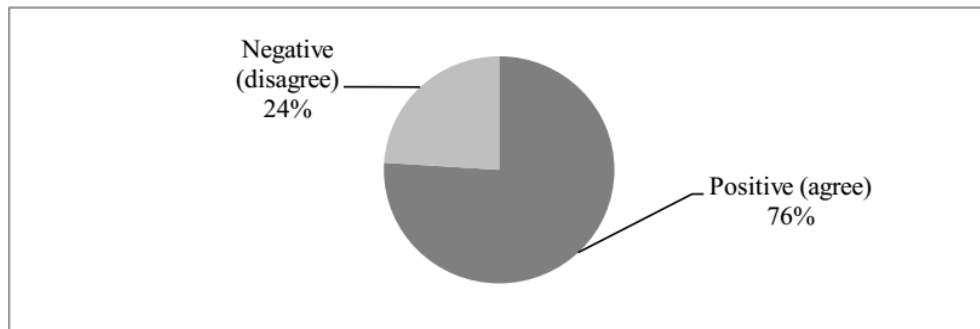

Figure 3. Extrovert Students’ Perception Percentage

The figure above shows extrovert students perceive positively towards CBL when they learned argumentative essay writing. It is proven by the percentage of 76% giving their positive agreement through the close-ended questions in the perception questionnaire.

Moreover, the following data were extrovert students’ perception towards CBL gotten from open-ended question of the questionnaire.

Table 3. Extrovert students’ perception towards CBL

Perception Preference		
Offline or face-to-face only (Off)	CBL	
	Positive Reasons (PR)	Problems Faced (PF)

a. It was more effective. (AD)	a. We could be diligent to write essay and improve writing skill. (AU)	a. It was difficult for students who did not like reading. (PIS)
b. We had not to type. (AD)	b. Lecturer could spread the knowledge, so the students say thanks. (ATR)	b. Students were not active to give feedback. (PIS)
c. It was more understandable. (AS)	c. We could have a good and correct essay. (MFW)	
d. We could get benefit to write essay. (MFW)	d. It was good idea. (PIS)	
e. It was more condusive because a student was busy in her business via online (WhatsApp). (Hm)		

Based on the table above, the extrovert students' perceptions about CBL in writing argumentative essay were positive and perception that CBL was good idea because they could increase their writing skill.

Introvert students' perception

Based on the data gotten from the perception questionnaire given to introvert students, we got the following data drawn in the table.

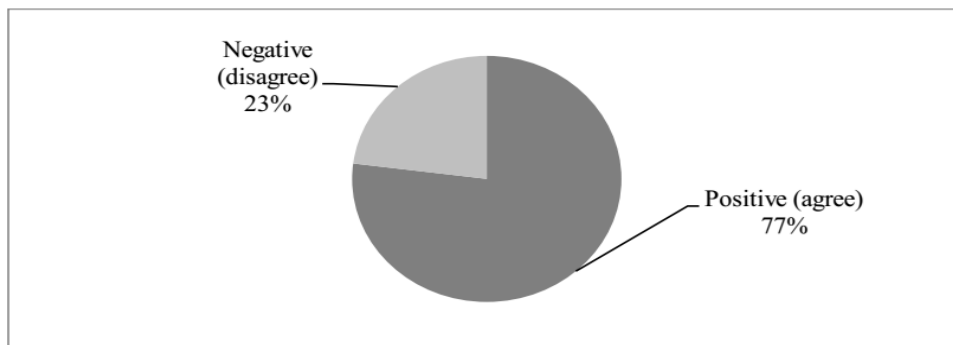

Figure 4. Introvert Students' Perception Percentage

The figure above shows introvert students perceive positively towards CBL when they learned argumentative essay writing. It is proven by the percentage of 77% giving their positive agreement through the close-ended questions in the perception questionnaire.

Table 4. Introvert students' perception towards CBL

Offline or face-to-face only (Off)	Perception Preference	
	CBL	
	Positive Reasons (PR)	Problems Faced (PF)
a. It was more effective. (BCM, LDJ, NEA, SO)	a. We could ask via WhatsApp when we were confused in writing. (BCM)	a. Because of broken or lost mobile phone, if we were out of the group, we lost information. (DRA, FR)
b. It was directly fast-respond learning. (HS)	b. It was effective. (DRA, EF, FR, HS, MO, MF, RI)	b. If we were very tired, we were lazy to open WhatsApp (to study). (EF)
c. It was more	c. The lecturers could explain	c. There were other subject tasks. (ET,

understandable, especially the lecturers' explanation. (NEA, N)	the material via CBL. (EF)	LDJ, MF)
d. It was more comfortable and enthusiasm. (TNH)	d. We could share materials needed, so we could add our knowledge. (FR, M)	d. It was a problem when we had no data balance. (FH)
	e. We could ask whenever. (FH)	e. It was slow respond because we did not hold mobile phone every time. (HS)
	f. It was good. (KAU)	f. Focus of the material had to be finished before discussing other materials in order that the students were not confused.
	g. We could ask without feeling shy. (M)	g. Grouping student system was not effective because the friends did want to work collaboratively, so it was as if we were study alone or only with lecturers. (M)
	a. Lecturer could spread the knowledge, so the students say thanks. (MSPA, NAY)	h. If they were back to their village, there was sometimes no internet signal. (MO)
	b. It could add our knowledge. (TD)	i. More responds from lecturers were needed to have better feedback. (RI)
		j. It was not as enthusiasm as in the class. (TNH)
		k. It was not as active as in the class if via WhatsApp. (TD)

Based on the table above, the extrovert students' perceptions about CBL in writing argumentative essay were positive and perception that CBL was good idea because they could increase their writing skill.

Thus, based on the results above, students' personalities of extrovert and introvert might take part to give impact to the application in which the students were grouped with the same personality they had. Hence, both of them got the better influence of CBL eventhough there was no different increase of argumentative essay writing ability between extrovert and introvert students after being taught by using Collaborative Blended Learning, but exactly each personality had its own perception faced the benefits and weaknesses of this learning way which used WhatsApp as the online learning medium as well as offline learning, and overall both extrovert and introvert students' perception was positive towards CBL in writing argumentative essay.

Moreover, the students' preference towards CBL of this research is in line with Lopez-Perez et al. (2010) stating that blended learning was interrelated with their final marks depending on the activities. In addition, they stated that it could improve the students' learning experiences by developing their capacity for reflection. The experiences were explained through their perceptions. Then, this study indicates that the designed collaborative activities in this research were favorable for the students in writing argumentative essay, for the

students could discuss and share their ideas as well as give feedback each others, so it impacted to their better ability in writing argumentative essay.

In addition, social media for learning in CBL could impact the university students' perception towards this learning directly because technology was their daily life instrument (Cotten, 2008). Moreover, the result was congruent with the research by Awada (2016) which used WhatsApp in CBL activities for students to write critique writing showing that WhatsApp was more effective than regular instruction, in which there was no technology engagement. Moreover, the students' perception in Awada's showed the increase of students' motivation to learn. Furthermore, this study also showed the students' positive perceptions generally included their motivation to follow CBL in Essay Writing course or if applied to learn other subject matters as well as their likeness to interact with peers or lecturers in order to have their better essay writing.

Therefore, both extrovert and introvert students' perceptions about CBL in writing argumentative essay were positive and perception that CBL was preferable because they could increase their writing skill by enjoying this learning broader just in the class via technology (WhatsApp) collaboratively.

IV. CONCLUSIONS AND SUGGESTIONS

In conclusion, based on the explanation above, both extrovert and introvert students are put together in the context that they are potential to learn with their own characteristics. The paradigm that the extroverts prefer spoken communication reveals that Collaborative Blended Learning is effective to increase their essay writing ability too since the collaborative group is suitable for them to discuss for their better essay drafts. Also, the introverts get necessity fulfillment to share their ideas through written form of essay. Thus, through CBL with WhatsApp use, both personalities are successful in writing argumentative essay proven by their increase of all essay writing aspects after passing the writing stages (planning, drafting, revising/ editing and publishing).

Thus, it seems that extrovert and introvert students perceive Collaborative Blended Learning (CBL) as an effective way to increase their habit and ability in writing because they could learn either in the classroom or out of the classroom and lesson hours via online media. Moreover, the use of WhatsApp as pedagogical online tool in Essay Writing class is an effective way for both personalities because they could broaden their knowledge related to the materials than just what they could know in the classroom. However, system management of WhatsApp use in CBL needs considerations more like time to respond and tasks given, so the students enjoy the learning sincerely without force or reluctance.

For the further study, it is hopefully that the sample size could be in big sample size (>30), and use better design with control class because this research used only small sample size after gotten the number of students in the class for extrovert and introvert students were less

than 30 students. Moreover, other aspects besides personality could be seen as they affect the learning process by using Collaborative Blended Learning.

REFERENCES

- Ahour, T. & Pezhman, N.H. (2014). The Comparative effect of using competitive & cooperative learning on the reading comprehension of introvert & extrovert efl learners. *Advances in Language & Literary Studies* ISSN: 2203-4714 Vol. 5 No. 4; August 2014
- Alarcon, J.B. & Katrina, N.S.M. (2011). Grammatical cohesion in students' argumentative essay. *Manila: Academic Journals: Journal of English & Literature* Vol. 25, pp. 114-127, June 2011
- Andriani, S. (2015). *Pengaruh model pembelajaran kooperatif tipe make a match terhadap kemampuan penalaran matematis siswa ditinjau dari tipe kepribadian*. B&R Lampung: IAIN Raden Intan Lampung
- Andújar-vaca, A. & Maria-Soledad, C. (2017). Mobile instant messaging: whatsapp & its potential to develop oral skills. *Comunicar, n. 50, v. XXV, 2017 | Media Education Research Journal*
- Awada, G.M. (2016). Effect of whatsapp on critique writing proficiency & perceptions toward learning. *Information & Communications Technology in Education Cogent Education* (2016), 3: 1264173
- Azizollah, D., Reza, Z., & Mohsen, R. (2013). Argumentative & narrative written task performance: differential effects of critical thinking. *International Journal of Research Studies in Language Learning* 2013 April, Volume 2 Number 2, 3-14
- Bahaziq, A. (2016). Cohesive devices in written discourse: a discourse analysis of a student's essay writing. *Canadian Center of Science & Education: English Language Teaching; Vol. 9, No. 7; 2016*
- Bailey, S. (2004). *Writing: A practical guide for students*. New York: Routledge Falmer
- Bath, D. & John, B. (2010). *Getting started with blended learning*. Griffith: Griffith Institute for Higher Education
- Broughton, G., Christopher, B., Roger, F., Peter, H. & Anita, P. (1980). *Teaching English as foreign language*. New York: Longman
- Cabero, J. (2010). Online students' satisfaction with blended learning. *Communar n.35 v. XVIII 2010 Scientific Journal of Media Literacy*
- Challob, A.I., Nadzrah, A.B., & Hafizah, L. (2016). Collaborative blended learning writing environment: effects on efl students' writing apprehension & writing performance. *Canadian Center of Science & Education: English Language Teaching; Vol. 9, No. 6; 2016*
- Cotton, S. R. (2008). Students' technology use & the impacts on well-being. *New Directions for Student Services, (124), 55-70*
- Dziuban, C.D., Joel L.M., & Patsy D.M. (2004). Blended learning. *EDUCAUSE Center for Applied Research* Vol. 2004 issue 7 March 30, 2004
- Ferriman, N. (2013). The impact of blended e-learning on undergraduate academic essay writing in English (L2). *Elsevier Computers & Education* 60 (2013) 243–253
- Fung, Y.M., & Hooi, C.M. (2015). Improving undergraduates' argumentative group essay writing through self-assessment. *Australian International Academic Centre Advances in Language & Literary Studies* ISSN: 2203-4714 Vol. 6 No. 5; October 2015

- Gholami, R. (2015). Difference between the performance of extrovert & introvert efl learners on task-based information-gap, opinion-gap & reasoning-gap activities. *GEORJ Vol. 1 Issue 3 – December 2015*
- Ghufron, M.A. (2016). A Model of research paper writing instructional materials for academic writing course: needs & documents analysis & model design. *Canadian Center of Science & Education: English Language Teaching; Vol. 9, No. 3; 2016*
- Hamad, M.M. (2015). Blended learning outcome vs. traditional learning outcome. *International Journal on Studies in English Language & Literature (IJSELL) Volume 3, Issue 4, April 2015, PP 75-78*
- _____. (2017). Using whatsapp to enhance students' learning of english language "experience to share". *Higher Education Studies Vol. 7 No. 4; 2017*
- Harmer, J. (2001). *How to teach english*. Edinburg Gate: Longman
- _____. (2002). *The Practice of English language teaching*. New York: Longman
- _____. (2007). *How to teach english*. London: Longman
- Harsasi, M., Mohammad, M., & Kurnia, E.R. (2008). Distance students' perception on the quality of computer-assisted instruction program in operation research course. *AAOU Journal, Vol. 3, No. 2, September 2008, 115-121*
- Hirsh, S.K. & Jane AG.K. (2006). *Work it out: Using personality type*. Mountain View: Davies-Black Publishing
- Hubackova, S., Ilona, S. & Blanka, F.K. (2011). Blended learning in a foreign language teaching. *Elsevier Procedia Social & Behavioral Sciences 28 (2011) 281 – 285*
- Jozsef, H. (2001). *Advanced Writing in English as a Foreign Language*. Pecs: Lingua Franca Csoport
- López-Pérez, M.V. (2011). Blended learning in higher education: Students' perceptions & their relation to outcomes. *Elsevier Computers & Education 56 (2011) 818–826*
- Madkour, M. (2016). The Effect of digital dialogued journaling on improving english writing: a linguistic communicative approach. *Canadian Center of Science & Education: English Language Teaching; Vol. 9, No. 8; 2016 ISSN 1916-4742 E-ISSN 1916-4750*
- Matzat, U. (2013). Do blended virtual learning communities enhance teachers' professional development more than purely virtual ones? A Large scale empirical comparison. *ELSEVIER Computers & Education 60 (2013) 40–51s*
- Maulan, S.B. & Raihan, I. (2012). The teaching & learning of english for academic purposes in blended environment. *The 3rd International Conference on e-Learning ICEL 2011, 23-24 November, B&ung, Indonesia*
- McClain, M. & Jacqueline, D.R. (1999). *Schaum's quick guide to writing great essays*. New York: McGraw-Hill
- McCrae, R.R. & Pault, C.J.R. (2003). *Personality in adulthood second edition a five-factor theory perspective*. New York & London: the Guilford Press
- McKay, P. (2008). *Assessing young language learners*. Cambridge: Cambridge University Press
- Miles, Ma.B. & A. Michael. (1994). *Qualitative data analysis*. Thous& Oaks: Sage Publications
- Nezakatgoo, B. (2010). *The effects of portfolio assessment on writing of efl students*. Tehran: AUameh Tabatabaie University
- Pourqardash, M. & Afshin, S. (2017). The effects of EFL learners' extroversion & introversion on their development of grammatical knowledge in terms of applying

- feedback types. *International Journal of English Research Volume 3; Issue 4; July 2017; Page No. 95-99*
- Purwanto, S. (2016). Improving academic writing skills through online mode of task-based assignments. *Canadian Center of Science & Education: English Language Teaching; Vol. 9, No. 9; 2016*
- Rambe, P. & Crispen, C. (2013). Using mobile devices to leverage student access to collaboratively-generated resources: A case of whatsapp instant messaging at a South African University. *International Conference on Advanced Information & Communication Technology for Education (ICAICTE 2013)*
- Richards, J.C. & Richard, S. (2002). *Longman dictionary of language teaching & applied linguistics*. London: Longman
- Schaefer, E. (2008). Rater bias patterns in an EFL writing assessment. *Language Testing 2008 25 (4) 465–493*
- Setiyadi, A.B. (2006). *Metode penelitian untuk penelitian bahasa asing*. Yogyakarta: Graha Ilmu
- Seufert, M., Tobias, H., Anika, S., Valentin, B. & Phuoc, T. (2016). *Group-based communication in whatsapp ifip networking*. Wurzburg: University of Wurzburg
- Shahrokni, S.A. & Ali, T. (2013). Learning processes in blended language learning: a mixed-methods approach. *The Electronic Journal for English as a Second Language November 2013 – Volume 17, Number 3*
- Shanmugapriya, Dr.S. & A. Priya. (2016). A Study on impact of using whatsapp on reduction of stress. *International Journal of Current Research & Modern Education (IJCRME) ISSN (Online): 2455–5428 (www.rdmodernresearch.com) Volume I, Issue II, 2016*
- Smalley, R.L. & Mary, K.R. (2000). *Refining composition skills*. New York: Macmillan
- Snodin, N.S. (2013). The Effects of blended learning with a cms on the development of autonomous learning: A Case study of different degrees of autonomy achieved by individual learners. *ELSEVIER Computers & Education 61 (2013) 209–216*
- Suliman, F.H.I. (2015). The Role of extrovert & introvert personality in second language acquisition. *IOSR Journal of Humanities & Social Science (IOSR-JHSS) Volume 20, Issue 2, Ver. V (Feb. 2015), PP 109-114*
- Syafi'i, A. (2016). *Blended learning to enhance students' motivation & english achievement at SMKN 3 Metro*. Unpublished thesis. Lampung: UNILA
- Thorne, K. (2003). *Blended learning how to integrate online & traditional learning*. London: Kogan Page
- Ulum, Ö.G. (2015). A Needs analysis study for preparatory class elt students. *European Journal of English Language Teaching Volume 1 Issue 1 2015 ISSN: 2501-7136*
- Yang, Y. & Wen-Ting, M. (2013). The effects of online feedback training on students' text revision. *Language Learning & Technology Volume 17, Number 2 pp. 220–238* http://ilt.msu.edu/issues/june2013/yang_meng.pdf June 2013
- Zafar, S. (2017). Extraversion-introversion tendencies & their relationship with esl proficiency: A Study of Chinese students in Vellore, India. *Pertanika J. Soc. Sci. & Hum. 25 (2): 687 - 704 (2017)*
- Zayed, N.M. (2016). Special designed activities for learning english language through the application of whatsapp!. *Canadian Center of Science & Education: English Language Teaching; Vol. 9, No. 2; 2016*
- Undang-undang SISDIKNAS 20/2003

About the Authors

Author 1

Complete Name : Ani Novitasari
Institution : Lampung University
Email Address : aninosaheri@gmail.com
Education : Master's degree in English Education
Research Interest : Teaching of writing

Author 2

Complete Name : Patuan Raja
Institution : Lampung University
Email Address : raja_pid@yahoo.com
Education : Professor of English Education
Research Interest : Teaching of Writing

Author 3

Complete Name : Flora
Institution : Lampung University
Email Address : nainggolan.flora@yahoo.com
Education : Doctor of English Education
Research Interest : Teaching of Writing

MOBILE LEARNING: THE IMPACT OF WHATSAPP USAGE IN ENGLISH LANGUAGE LEARNING

Berlinda Mandasari¹, Shafa Tiara Pangestika Agusty²
Universitas Teknokrat Indonesia^{1,2}
berlinda@teknokrat.ac.id¹

ABSTRACT

Mobile learning is a new trend in educational environment. Utilizing some applications in mobile phones has greatly influenced the learning process. One of the common applications used to support learning process is WhatsApp. This application contains some features that enable the users to share informations with others. Thus, this study attempts to uncover the impact of whatsapp usage in English language learning. The participants of this research were 49 students majoring English Education Department who use WhatsApp in learning English. Interview and questionnaire were used to collect the data. The data were analyzed through descriptive analysis. The result revealed that WhatsApp usage had impact on students' attitude and motivations. Students had positive attitude and high motivation towards English language learning through WhatsApp. However, WhatsApp usage demanded students to have unlimited internet connection which meant that they need to spend some cost to support mobile learning process. It is suggested that there was a free access of internet connection that could help students conduct the mobile learning.

Keywords: *mobile learning, whatsapp, English language learning*

I. INTRODUCTION

Industrial revolution 4.0 is the starting point of the development of technology. People are now familiar with some product of technology. One of them is smart phones. People can easily share photos and videos through some social media. Therefore, smart phone gives an easy access for people to obtain information that can help them enrich their knowledge toward the world and benefit themselves.

Toward the benefit of having smart phone, it gives such influence for students. Smart phone has grasped students attention. Consequently, they less focus on lessons given by lecturer in the classroom. Moreover, students become alienated because they rare conduct face-to-face interaction with their friends. Therefore, they isolate themselves from environment. In fact, interaction and collaboration in the classroom will be very beneficial for students to increase their ability and manage their social attitude. An action need to be taken to incorporate students on their use of smart phones and educational aspect. he mobile phone is used as a collaborative tool for student with the support of collaborative learning strategy (Sulisworo, Rahayu, & Akhsan, 2016).

Smart phones can be very useful when it is used in a good purpose. Mobile devices may enhance productive learning “where learners show responsibility for and initiate their own learning, share learning with experts and peers” (Vavoula & Sharples, 2008). Mobile devices can also help students enjoy an autonomous learning environment (Sharples, Taylor & Vavoula, 2005; Fisher & Baird, 2007; Petersen, Divitini, & Chabert, 2008; Benson & Chik, 2010) that is personalized (Harley, Winn, Pemberton, & Wilcox, 2007; Hayati, Jalilifar, & Mashhadi, 2013). As such, mobile learning is aligned with the learner-centered approach to learning. Some applications in smart phone can be used as medium to learn English. One of them is WhatsApp. WhatsApp mobile application consists of some features, texts which is simple and reliable, group chat which keeps in touch, WhatsApp voice and video calls and Whatsapp on web and desktop. This features can help students to conduct English language learning inside or outside of the classroom.

Smartphones as learning tools have gained popularity among many educators who believe that they offer flexibility in terms of time and location (Demouy & Kukulska-Hulme, 2010; KukulskaHulme, 2012) and allow students to enjoy a personalized learning environment (Harley, Winn, Pemberton, & Wilcox, 2007; Hayati, et al., 2013). Students tend to enjoy using their smartphones because they can easily access the learning materials and can practice the language anytime and anywhere (Chen, Hsieh, & Kinshuk, 2008) and continue their learning even after class time (Laurillard, 2007). White and Mills (2011) have reported that learners generally have positive attitudes towards using smartphones for language learning. Utilizing instruction through mobile phones in language learning results different environment compared to traditional ways. Students are exposed to materials given by teachers in the classroom which later on they need to complete their home task outside the classroom. This home task is expected to be completed by students by making use of smart phones. It enables students to consult their works with peers and teachers at any time. (Creseen & Lee, 2011).

Some studies conducted by some researchers about utilizing WhatsApp in English language learning. Alsaleem (2013) examined the effect of the use of WhatsApp on English as Foreign Language (EFL) students in written vocabulary tasks in Saudi Arabia. The author found that WhatsApp had a positive effect on students’ performances. The students enjoyed using WhatsApp as a learning tool. They perceived the use of WhatsApp as a game rather than a formal class requirement. Malecela (2016) examined students’ perceptions of the use of WhatsApp as a learning tool ina university in Malaysia. A qualitative research design was followed in which interviews were conducted with some students. The results showed that the students believed that WhatsApp could be helpful in their learning by facilitating: communication with other students and with the instructor, collaborative learning, and access to and sharing of educational information. WhatsApp can be used as a medium for learning and teaching the English language.

The impact of WhatsApp was also examined in the Turkish context. Basal, Yilmaz, Tanriverdi and Sari (2016) examined the effectiveness of WhatsApp in learning idioms from the Michigan Corpus of Academic Spoken English compared to traditional classroom activities. The participants were 50 first-year students from a university in

Turkey. Results indicated that participants in the experimental group achieved higher scores than the control group in the posttest. The researchers concluded that WhatsApp has a positive impact on learning idioms. Bere (2013) found that WhatsApp could be useful to “create alternative dialogic spaces for student collaborative engagements in informal contexts, which can gainfully transform teaching and learning”. Tang and Hew (2017) reported that WhatsApp had been used in different academic disciplines to support students’ learning. Ngaleka and Uys (2013) reported that WhatsApp can be used to facilitate mobile learning. In their study the students used WhatsApp as a communication tool outside the classroom to exchange information about meetings and projects. Barhoumi (2015) found that the use of WhatsApp to facilitate blended learning had a positive and significant impact on students’ learning performance and their attitudes toward blended learning.

Utilizing WhatsApp as a tool to support English language learning has not been studied in the scope of Universitas Teknokrat Indonesia. The implementation of blended learning uses another application which is officially launched by institution. However, this study will maximize WhatsApp application as a supportive tool to carry out English language learning, so that learning process can happen anytime and anywhere. The finding of this research can contribute to add more references to the study using mobile learning. Harmer (1999) explains the meaning of motivation as the “internal drive” that pushes somebody to do something. If we think that our goal is worth doing and attractive for us, then we try to reach that goal; this is called “the action driven by motivation”. Lightbown and Spada (1999) note that motivation in second language learning is quite complicated to study which can be explained in terms of two factors: learner’s communicative needs and their attitudes towards the second language community. In addition, Parsons, Hinson and Brown (2001) define motivation as an important component or factor in the learning process. Learning and motivation have the same importance in order to achieve something. Learning makes us gain new knowledge and skills and motivation pushes us or encourages us to go through the learning process.

This study attempts to identify students’ attitude in learning English through WhatsApp and investigate students’ motivation in using WhatsApp to learn English.

Research Questions

1. What is students’ attitude towards using WhatsApp in English language learning?
2. What is students’ motivation to use WhatsApp in English language learning?

The objective of the study

The objective of this study is to identify students’ attitude towards using WhatsApp in English language learning and students’ motivation to use WhatsApp in English language learning.

II. METHODS

Design

The researcher used analytical descriptive method in conducting this study.

Participants

Participants of this study is forty nine students male-female studying at Universitas Teknokrat Indonesia majoring English Education study Program who take Child Development course in third semester 2018/2019. All participants need to discuss the topics given by the lecturers through WhatsApp group. They need to discuss the topics together with members of the group. Then, each topics will be concluded by the lecturers. This activities consistantly done by the groups as an additional meeting for discussion instead of face-to-face interaction.

Materials and procedure

Topics being discussed in the group are parts of child development subject. It covers growth and development, cognitive development, affective development and phases of development. Within those topics, students need to find out its implication in English language teaching. They discuss the topics by giving evidence from experts. Then, lecturers will monitors the discussion and lead the students to discuss on one track. At the end, lecturer will conclude the discussion.

Instrument of the study

The instrument used to collect the data were questionnaire and interview. Questionnaire is constructed from the theories of attitude and motivation. There are five scales used in this questionnaire started from Strongly agree until strongly disagree (5-1). The evaluation criteria to measure students' attitude are as follows:

0-2.50 Negative attitude toward using WhatsApp in English Language Learning
2.51-3.50 Neutral attitude toward using WhatsApp in English Language Learning
3.51-5.00 Positive attitude toward using WhatsApp in English Language Learning

The evaluation criteria to measure students' attitude are as follows:

0-2.50 Low motivation toward using WhatsApp in English Language Learning
2.51-3.50 Moderate motivation toward using WhatsApp in English Language Learning
3.51-5.00 High motivation toward using WhatsApp in English Language Learning

The researcher also used interview as instrument of this study. This interview section is used to clarify the data obtained by using questionnaire. The result of interview can strengthen the result of questionnaire.

The questions of questionnaire are:

1. What is the benefit of using WhatsApp message feature?
2. Can you consult your assignment easily to your lecturer?
3. Is there any improvement of your new vocabulary?

4. What is the benefit of voice recorder feature?
5. What is the benefit of video recorder feature?
6. Is there any improvement toward your confidence in learning English through WhatsApp?
7. What are disadvantages of using WhatsApp in English language learning?

III. RESULTS AND DISCUSSIONS

Results

The charts below is the data of participants in this research. All participants have installed WhatsApp application on their mobile phone. The participants aged in the range of 17-21 years old. The total participants are 49 in which 40 numbers of participants are female, 9 are male.

Do you install WhatsApp application on your smart phones?

49 responses

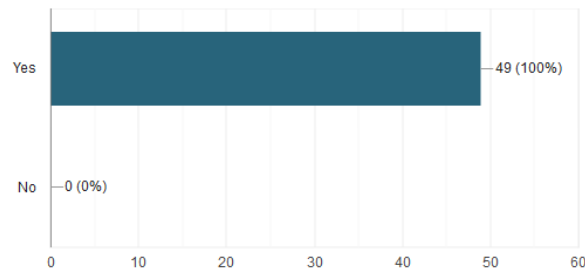

How old are you? (Years old)

49 responses

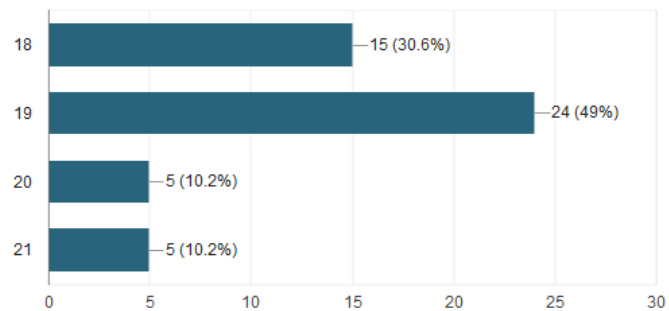

Are you male or female?

49 responses

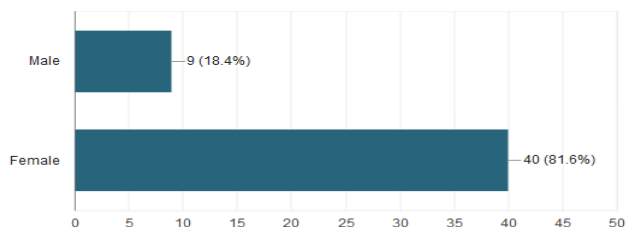

Students' attitude toward using WhatsApp in English language learning

Based on the objective of the study, the finding of this study are divided into two; identifying students' attitude and students' motivation toward using WhatsApp in English language learning. The first finding is presented on the table below.

Tabel 1. Students' attitude toward using WhatsApp in English language learning

No	Statements	Mean	SD	Interpret
1	I can easily have interaction with my friends in English using WhatsApp message feature.	4,08	0,84	Positive Attitude
2	Using WhatsApp enables me to consult my assignments to my lecturer.	4,39	0,73	Positive Attitude
3	Using WhatsApp helps me to learn English easier.	3,88	0,9	Positive Attitude
4	I feel more convenient learning English.	3,42	0,87	Neutral Attitude
5	I can easily memorize new English words.	3,69	0,85	Positive Attitude
6	I can ask my friends to correct my English pronunciation by using audio recording feature.	3,98	0,85	Positive Attitude
7	I can easily post any pictures with caption written in English.	4,04	0,71	Positive Attitude
8	WhatsApp enables me to complete my activities in real situation by using video recording feature.	3,84	0,75	Positive Attitude
9	WhatsApp helps me discuss my problem to my lecturer personally.	3,82	0,7	Positive Attitude
10	Using WhatsApp helps me to improve my English through recording my performance and share the recording to my lecturers.	3,67	0,92	Positive Attitude
AVERAGE		3,881	0,812	

The finding revealed that students had positive attitude towards using WhatsApp in English language learning. It can be seen from the result of questionnaire which is 3,881. This number indicates that students can WhatsApp brings benefit for the students. 81,6% of students agree that they can easily do interaction with others through WhatsApp message (Chat feature). This chat feature enables them to discuss materials to their friends and lecturers. By having this feature, students can easily send message anytime and anywhere. As it is supported by Cohevi (2013) who said that WhatsApp is learning resources can be accessed anytime, anywhere and in any features. It could help in developing the student's learning performance though.

Students also do agree that WhatsApp help them to consult their assignment to their lecturer. The use of WhatsApp gives a space for students to consult the assignment personally to the lecturer. This activities open a two-way communication between students and lecturer to have a personal discussion. Moreover, students can also discuss about problem faced by them. It is also supported by Norfaezah (2015) who stated that the use of WhatsApp can help the students to share many things with the lecturer. This statement is also supported by the result of interview section.

*“ I used to text my lecturer personally to ask clarification for my assignment. So, I can get clear information about my assignment. Sometimes, I text my lecturer when I got problem in my academic study. I think it is quite helpful for me”
(Student A)*

Some students also agree that WhatsApp helps them to learn English easier. This point explains that when discussion is done using English, some students might learn better. They can easily understand the conversation. Unless, they can easily ask for clarification. In addition, students can get more vocabulary. It is because when texts are written in English, students can enrich their vocabulary. They possibly find a new words. Therefore, they can add the new words on their memory. This statement is supported by the result of interview section.

“ My English is improve when I get accustomed to have interaction through WhatsApp message in English. I find the correct English words before I write my ideas in the group. I did so because I don't want to create an ambiguous statement. Unconsciously, I read first before I write message” (Student B)

“I get more vocabulary when I use WhatsApp to communicate in English. Some friends use new words that I have never seen before in expressing their ideas. So, I can increase my vocabulary” (Student C)

Students also do agree that they can easily ask their friends to check their pronunciation through voice recording in WhatsApp feature. This activities can easily be done by students because voice recording feature can record students' voice and be sent to the receiver. This statement is supported by Ida Sanjaya (2012) who found that majority of users are interested in using WhatsApp application because this application provides

many attractive facilities such as sharing information in the form of audios, videos, images, or even sharing location of the user's place. Many things can be done via this application.

"I used to record my voice through voice recorder in WhatsApp and ask my friend to check my English pronunciation. We sometimes remember the materials about pronunciation subject. So, we can learn together" (student D)

Majority of students do agree that WhatsApp can explain the real situation done by students through video recording feature. This feature can give live report from students toward what they are doing. In the case of English language learning, this activity is done when students need to present their assignment. They need to record their performance and share their recording to the group. Then, their friends will criticize the content of presentation. Moreover, students increase their confidence in speaking English. Using WhatsApp may have helped participants feel less inhibited and thus has boosted their confidence to be actively involved in the learning process as reported by Wada (2016) and it positively impacted their language performance. In addition, Han & Keskin (2016) reported that using WhatsApp significantly impacted the students' language acquisition by lowering EFL speaking anxiety. This finding is also supported by the result of interview section.

"I feel more confident when I have to record my performance or my presentation and share it to my friends. Thus, I can get feedback toward my performance so that I can make it must better" (Student E)

despite having benefit toward English language learning, WhatsApp may give disadvantages. Based on the result of interview, students confirm that using WhatsApp in English language learning requires them to have unlimited internet connection. It means that they need to spend more money to fulfill the need of internet access. It may cost them a lot.

"I like using my WhatsApp account that benefit for me. However, I need to have unlimited internet connection. It cost me some money because I need to be online based on the schedule. Hopefully I can be facilitated with free internet connection" (Student F)

Toward the challenge, it is notified that students need to have internet connection when they are outside of the college. College has facilitate them with free hotspot that can be access by all students. However, this free hotspot can not reach the far away distance. This case must be handled wisely so that students won't be burdened.

Students' motivation toward using WhatsApp in English language learning

Table 2. Students' motivation toward using WhatsApp in English language learning

No	Statement	Mean	SD	Interpret
1	WhatsApp motivates me to conduct interaction with my lecturer in written English.	3,73	0,73	High Motivation
2	WhatsApp motivates me to discuss my problem in English.	3,37	0,78	Moderate Motivation
3	WhatsApp motivates me to discuss my assignment with my friends and get direct feedback from my lecturer.	3,65	0,91	High Motivation
4	Whatsapp motivates me to post my video to easily.	3,82	0,97	High Motivation
5	Whatsapp motivates me to chat with my lecturer easily anytime and anywhere.	3,88	0,97	High Motivation
6	Whatsapp motivates me to quickly share information to my friends.	3,63	0,83	High Motivation
7	Whatsapp motivates me to understand the English materials.	3,27	0,88	Moderate Motivation
8	Whatsapp motivates me to read information pleasantly.	3,24	0,97	Moderate Motivation
9	Whatsapp motivates me to get more knowledge in English vocabulary.	3,54	1	High Motivation
10	Whatsapp motivates me to send my voice recording in English.	3,27	0,73	Moderate Motivation
AVERAGE		3,54	0,877	

The data above revealed that students have high motivation to learning English through WhatsApp. It can be proven by the result of questionnaire in which the mean score is 3,54. This number indicates that students are internally and externally motivated to learn English through WhatsApp application. From the data, it can be seen that the usefulness of WhatsApp which equipped with internet connection and supported by some features has motivated students to solve their problem in learning English and improve their English ability.

Discussions

The present study is designed to identify the students' attitude toward using WhatsApp in English language learning and students' motivation on it. The result showed that students have positive attitude toward using WhatsApp in English language learning. WhatsApp is an effective tool to conduct blended learning because most people have WhatsApp

application on their mobile phones. Making use of this application as medium of learning is a kind of innovation in optimizing technology in English language learning. The result of this study is supported by Hamad (2017). He conducted research to thirty six students female-students studying at College of Science & Arts Majarda English Department in the 1st level who were studying listening & Speaking 1 course in the 1st semester 2013-2014 in Saudi Arabia. He found that WhatsApp have advantages for their students. There was clear development of students' performance after studying through WhatsApp. Another expert who support the finding is Mahmoud Aburezeqand Fawzi Fayezi Ishtaiwa (2013) in their study: "*The Impact of WhatsApp in Interaction an Arabic Language Teaching Course*", revealed WhatsApp platform offers them a space for communicating, expressing ideas and exchanging information anytime and anywhere. However, (a) expenses involved in WhatsApp use, (b) extra work load, (c) distraction to learning, and (d) lack of students' commitment for effective participation were identified as the greatest challenges of effective WhatsApp use for learning purposes.

Hani (2014) in his study: *The Impact of WhatsApp Group's Utilization of EFL Students' Vocabulary Writing Amelioration* showed that the findings imply a significant difference between the overall writing scores of the pretest and posttest of the participants who used journaling. Additionally, test of individual item scores shows that there are statistically significant developments in vocabulary choice and voice as two pivotal writing characteristics. The study can promote a favorable educational change by assisting teachers grasp the possible merits of WhatsApp electronic dialogue journaling to develop the vocabulary word choice and voice writing skills of their students. Yeboah and Ewur (2014) examined higher education students' use of WhatsApp. Four hundred and eighteen students completed a questionnaire. The results showed that most were heavy users of WhatsApp. More than 96% of the participants reported using it for more than three hours a day. Most participants used WhatsApp for chatting while only 7% reported using it for academic work.

The use of WhatsApp has somehow liberated students who lack confidence to participate in class. As many studies have reported (e.g. Alrabai, 2014; Al-Saraj 2014) Arab students typically experience high levels of anxiety while speaking foreign languages in class.

The second finding is that students have high motivation toward using WhatsApp in English language learning. The overall reason is that students' need to solve their problem in learning English and improve their English ability.

IV. CONCLUSIONS AND SUGGESTIONS

This study tried to identify the students' attitude toward WhatsApp in English language learning. The result shows that students have positive attitude toward using WhatsApp in English language learning. WhatsApp is an effective mobile application to apply mobile learning. Therefore, it is suggested for educators to make use of this application to support English language teaching and learning. WhatsApp application is considered as product of technology that gives advantages for students to learn English inside and outside the classroom, anytime and anywhere.

This study also identified students' motivation toward using WhatsApp in English language learning. The result showed that students have high motivation to learn English through WhatsApp. WhatsApp enables them to consult their problem in learning English and their needs of improving their English ability. Since all students use smart phones, it is recommended that educators consider using WhatsApp to discuss assignment.

Despite the advantages presented in this research, students found that they need to have unlimited internet connection to apply this mobile learning. It costs the students money to provide 24 hours internet connection. It is suggested that there must be some other solutions for this case, especially when the mobile learning is conducted outside of the institution. There are some other space to conduct the research in this area. The present study limits only on the students' attitude and motivation.

REFERENCES

- Alsalem, B. I. A. (2013). The effect of "Whatsapp" electronic dialogue journaling on improving writing Vocabulary Word Choice and Voice of EFL Undergraduate Saudi Students. *Arab World English Journal*, 4(3), 213-225.
- Bere, A. (2012, September). A comparative study of student experiences of ubiquitous learning via mobile devices and learner management systems at a South African university. In 2012 Conference.
- Chen, N.-S., Hsieh, Sh.-W., & Kinshuk, W. (2008). The effects of short-term memory and content representation type on mobile language learning. *Journal of Learning and Technology*, 12, 93-113.
- Cohavi, A. (2013). How did WhatsApp became the strongest social network? Calcalist. (online) <http://www.calcalist.co.il/local/articles/0,7340,L-3593840,00.html>
- Creseen, M. L., & Lee, D. (2011). Critical issues of m-learning: design models, adoption processes, and future trends. *Journal of the Chinese Institute of Industrial Engineers*, 28(2), 111-123.
- Demouy, V., & Kukulska-Hulme, A. (2010). On the spot: using mobile devices for listening and speaking practice on a French language programme. *Open Learning*, 25(3), 217- 232.
- Gardner, R. C., and Lambert, W.E. (1972). *Attitude and Motivation in Second Language Learning*. Rowley, MA: Newbury House.
- Gardner, R.C. (1985). *Social psychology and second language learning: The role of attitudes and motivation*. London : Edward Arnold.
- Laurillard, D. (2007). Pedagogical forms for mobile learning: Framing research questions. In N. Pachler (Ed.), *Mobile learning: Towards a research agenda*, 1, 153-175. London: WLE Centre for Excellence, Institute of Education.
- Lightbown, P.M., & Spada, N. (1999). *How languages are learned*. Oxford: Oxford University.
- Kukulska-Hulme, A. (2012), Language learning defined by time and place: A framework for next generation designs. In Díaz-Vera J. E. (Ed.). *Left to My Own Devices: Learner Autonomy and Mobile Assisted Language Learning. Innovation and Leadership in English Language Teaching*, 6, 1-13. UK: Emerald Group Publishing Limited.

- Malecela, I. O. (2016). Usage of Whatsapp among Postgraduate Students of Kulliyah of Education, International Islamic University Malaysia. *International Journal of Advanced Engineering Research and Science*.
- Ngaleka, A., & Uys, W. (2013, June). M-learning with whatsapp: A conversation analysis. In *International Conference on e-Learning*(p. 282). Academic Conferences International Limited.
- Norfaezah Mohd Hamidin. (2015). Penggunaan aplikasi ‘whatsapp’ dalam pembelajaran & pengajaran (P&P) di KUIS. *1stGlobal Conference on Technology in Language Learning 2015 (GLIT2015)*.
- Harmer, J. (1991). *The practice of English language teaching*. London: Longman.
- Sharples, M., Taylor, J., & Vavoula, G. (2005). *Towards a theory of mobile learning*. Paper presented at 4th World Conference on mLearning, Cape Town, South Africa.
- Sharples, M., Taylor, J., & Vavoula, G. (2007). A theory for the mobile age. In R. Andrews & C. Haythronwaite (Eds.), *The Sage handbook of E-learning research* (pp. 221 -247). London: Sage.
- Sulisworo, D., Yunita, L., & Komalasari, A. (2017). Which mobile learning is more suitable on physics learning in Indonesian high school? *International Journal of Recent Contributions from Engineering, Science & IT*, 5(1), 97-104.
- Tang, Y., & Hew, K. F. (2017). Is mobile instant messaging (MIM) useful in education? Examining its technological, pedagogical, and social affordances. *Educational Research Review*.
- Vavoula, G. & Sharples, M. (2008) Challenges in evaluating mobile informal learning. In *Proceedings of the mLearn 2008 conference* (pp. 296-303). UK: Wolverhampton.

About the Authors

Author 1

Complete Name : Berlinda Mandasari
Institution : Universitas Teknokrat Indonesia
Email Address: : berlinda@teknokrat.ac.id
Education : Magister of English Education
Research Interest : Teaching media, Teaching English as Foreign Language, Language Assessment

Author 2

Complete Name : Shafa Tiara Pangestika Agusty
Institution : Universitas Teknokrat Indonesia
Email Address : shafaagusty@gmail.com
Education : Student of English Education Study Program
Research Interest : Teaching English as Foreign Language

UNDERGRADUATE STUDENTS' ATTITUDES TO THE IMPLEMENTATION OF WHATSAPP GROUP AS THEIR LEARNING MEDIA IN THE EFL CLASSROOM

Fatimah Mulya Sari

English Language Education Department
Faculty of Arts and Education, Universitas Teknokrat Indonesia
fatimah@teknokrat.ac.id

ABSTRACT

This article draws on qualitative data from a case study of an EFL classroom for English Literature students at the Indonesian tertiary context. This study aims at revealing the students' attitude toward the implementation of WhatsApp Group and the problems affecting its process of teaching and learning. This study was conducted at one of Lampung's higher learning institutions. It was involved one course subject with 21 students and covered both the sessions when they studied through mobile learning and face-to-face learning. The data obtained were from observation, interview, and questionnaire. The questionnaire was used to find out the students' attitude toward WhatsApp Group. Meanwhile, interview was used to explore the problems which become the influential factors in its implementation. The findings indicate that the students significantly had a very positive attitude towards the implementation of WhatsApp Group. The students also gained some benefits of using WhatsApp Group in their language learning. Besides, they also admitted that messages overloading, mistyping, and slow internet connection were the most problems occurred. Thus, this new trend of teaching media requires a retrospective evaluation to assure that language learning works as what they were intended.

Keywords: *WhatsApp group, students' attitude, EFL classroom*

I. INTRODUCTION

Education nowadays is acquainted with the term of technology. Technology has been playing a pivotal role in education field over the past decade. The previous studies have proven the vitality of technology because it eases the life and transformed the way of communication. Subsequently, the rapid development in technology tremendously changes our strategies and concepts of teaching and learning. Teaching and learning process is not only using books or printed materials but also utilizing sophisticated tools as teachers and learners have been lived in the technology era and become native to digital technology. They are surrounded with gadgets and easy access to information for the teaching materials. These development also minimizes the existence of face-to-face learning into blended learning or full online learning.

Currently, increasing number of higher education institutions has implemented a technology-based learning system, well-known as blended learning. Blended learning is a relatively new term in education field which is integrated face to face learning and online learning to enhance teaching and learning activities (Bath & Bourke, 2010; Cheung & Hew, 2011; Sharma & Barret, 2011). One of blended learning waysis through social media. One of useful social media among the teachers and students is WhatsApp.

WhatsApp is a simple tool which can be used as self-assisted learning. It can be used freely for texting, calling, and sharing a content such as audio, video, images, location, and contacts. The users are able to create a specific group in the WhatsApp to share information and communicate outside the classroom. Moreover, WhatsApp is initially developed for mobile platforms, its web, and desktop version.

Choosing the right teaching-learning media for language learning leads to positive attitude of learners and also contribute to their language learning. Many researchers have discussed the advantages of using social media as learning media in language learning. The popularity of WhatsApp has increased the many language educators' interest in conducting studies to explore the potential of utilizing WhatsApp in teaching and learning process, especially in teaching certain aspects of foreign language learning. From the numerous studies, the findings have shown that implementing WhatsApp is effective tool and potentially supports teaching-learning process (Bouhnik & Deshen, 2014; Çetinkaya & Sütçü, 2018).

In this study, the writer developed face-to-face learning and self-assisted learning using WhatsApp Group in the English Literature class. The purpose was to explore the students' attitudes toward the implementation of WhatsApp Group as their teaching-learning media. In addition, it also revealed the problems affecting the process of teaching and learning using this teaching platform.

II. METHODS

This study was a qualitative study that was conducted in a higher learning institution in Bandar Lampung. The subjects of this research were third-year students from English Literature major, Faculty of Arts and Education, University of Teknokrat Indonesia. Regarding their blended learning experience for language learning, they have been experienced for one and a half year. They also have been familiar with blended learning through social media such as Facebook and Instagram.

The data obtained were questionnaire, interview, and observation. Questionnaires were distributed to 21 respondents. The questionnaires consisted of 15 statements. They were modified from Minalla (2018) and Gon & Rawekar (2017). To analyze the data obtained from the questionnaires, the Likert Scale was used with the indicators strongly disagree, disagree, neutral/moderate, agree, and strongly agree. The scores interpretation has a comprehension range of scores. First, item percentage of 0-20% interprets very insignificant. Second, item percentage of 21-40% interprets insignificant. Third, item percentage of 41-60% interprets sufficient/enough. Fourth, item percentage of 61-80% interprets significant. Last, item percentage of 81-100% interprets very significant (Riduwan, 2008). This interpretation was aimed to explore the significance of each item based on the students' attitude toward the implementation of WhatsApp Group. In addition, the open-ended interview was conducted to support the result from questionnaire and observation. There were 15 students to be interviewed relating to the implementation of this teaching platform. They were chosen randomly as there were only 21 participants in this research.

III. RESULTS AND DISCUSSIONS

To explore the students' attitudes toward the implementation of WhatsApp Group, the questionnaires were distributed to the students. The results can be seen in the table 1, as follows:

Table 1. The Students' Attitudes toward the Implementation of WhatsApp Group

No	Statement	5	4	3	2	1
1	WhatsApp Group Chat is an interesting teaching-learning platform.	4 (19,05%)	16 (76,19%)	1 (4,76%)	0 (0%)	0 (0%)
2	WhatsApp Group Chat provides a conducive environment.	4 (19,05%)	12 (57,14%)	5 (23,81%)	0 (0%)	0 (0%)
3	Students have sense of belonging to the group.	1 (4,76%)	11 (52,38%)	9 (42,86%)	0 (0%)	0 (0%)
4	There is a sufficiency of the time to finish tests and assignment.	3 (14,29%)	12 (57,14%)	6 (28,57%)	0 (0%)	0 (0%)
5	WhatsApp Group Chat is an appropriate platform English for Foreign Language (EFL) verbal interaction outside classroom context.	3 (14,29%)	11 (52,38%)	7 (33,33%)	0 (0%)	0 (0%)
6	WhatsApp Group Chat creates interaction between students.	5 (23,81%)	14 (66,67%)	2 (9,52%)	0 (0%)	0 (0%)
7	WhatsApp Group Chat creates interaction with facilitator (lecturer).	5 (23,81%)	16 (76,19%)	0 (0%)	0 (0%)	0 (0%)
8	WhatsApp Group Chat shares learning material.	7 (33,33%)	14 (66,67%)	0 (0%)	0 (0%)	0 (0%)
9	The knowledge is clearly constructed and shared.	3 (14,29%)	8 (38,1%)	9 (42,86%)	1 (4,76%)	0 (0%)
10	WhatsApp Group Chat is an appropriate platform for practicing for what you have routinely learnt in the classroom contexts.	1 (4,76%)	10 (47,62%)	10 (47,62%)	0 (0%)	0 (0%)
11	WhatsApp Group Chat is an appropriate platform for further practicing of the target language.	1 (4,76%)	13 (61,9%)	5 (23,81%)	2 (9,52%)	0 (0%)
12	WhatsApp Group Chat is an appropriate platform for supporting your present language attitudes.	1 (4,76%)	13 (61,9%)	7 (33,33%)	0 (0%)	0 (0%)
13	WhatsApp Group Chat helps to create opportunity for communication. Whenever I make mistakes, I can revise them to be a perfect assignment.	5 (23,81%)	15 (71,43%)	1 (4,76%)	0 (0%)	0 (0%)
14	In WhatsApp Group Chat, doubts immediately cleared.	1 (4,76%)	6 (28,57%)	8 (38,1%)	6 (28,57%)	0 (0%)
15	The cognitive legibility is provided for us.	0 (0%)	14 (66,67%)	7 (33,33%)	0 (0%)	0 (0%)

Based on the result of the questionnaires, there were various students' responses toward the statements given. The first statement of the questionnaire shows that there were 16 students (76,19%) who agreed that WhatsApp Group is an interesting teaching-learning platform. Besides, the students found themselves very significantly interested on WhatsApp Group Chat as their teaching-learning platform (19,05%). Meanwhile, there was one student (4,76%) who chose neutral. In the second statement, 12 students (57,14%) who agreed that this teaching-learning platform provides a conducive environment. The rest of them stated strongly agree (19,05%) and neutral (23,81%).

Moreover, the students significantly had sense of belonging to the group (52,38%). There were 9 students (42,86%) who were neutral and one student (4,76%) who strongly agreed for the third statement. More than 52% students agreed that there was enough time to accomplish the assignment and they considered this media as an appropriate platform to create interaction outside the classroom. They also significantly revealed that WhatsApp Group Chat created the verbal interaction among students and lecturer. There were 14 students (66,67%) who agreed and 5 students (23,81%) who strongly agreed that the interaction between students occurred through WhatsApp Group Chat. Two students (9,52%) preferred neutral/moderate. On the other side, 16 students (76,19%) stated agree that this teaching-learning platform also could create interaction between students and lecturer. The other students (23,81%) show very significant response to its statement.

Moreover, there were 14 students (66,67%) who admitted that WhatsApp Group Chat is also useful for sharing learning material in any form of docx., pdf., jpeg., or .pptx. The other 7 students (33,33%) also strongly agreed about it. In addition, there were 9 students (42,86%) who did not decide whether they agreed or disagreed that the knowledge was clearly constructed and shared through this platform. 8 students (38,1%) stated agree that the knowledge was clearly constructed and shared. The other 3 students (14,29%) strongly agreed and 1 student (4,76%) disagreed that the knowledge was clearly constructed and shared through this teaching-learning platform.

Furthermore, 10 students (47,62%) agreed that WhatsApp Group Chat is an appropriate platform for practicing for what you have routinely learnt in the classroom contexts. On the other hand, there were 10 neutral students (47,62%) who did not decide their responses, while there was only one student who strongly agreed to this statement. There were 13 students (61,9%) who agreed that WhatsApp Group Chat is an appropriate platform for further practicing of the target language and supporting your present language attitudes. Only one student strongly agreed with it. But, less than 33% students showed their neutral responses toward this statement.

Subsequently, the students who agreed that 'WhatsApp Group Chat helped to create opportunity for communication; Whenever they made mistakes, they could revise them to be a perfect assignment' took the percentage 71,43% or 15 students. The other 5 students (23,81%) strongly agreed with it, but there was one neutral student. Then, there were various responses toward the statement of 'in WhatsApp Group Chat, doubts immediately cleared'. There were each 6 students (28,57%) who agreed and disagreed. The other 8 students (38,1%) were neutral and one student (4,76%) strongly agreed. Lastly, 14

students (66,67%) agreed that the cognitive legibility is also provided for them during teaching-learning process through this platform.

The results of the quantification show that the students gave positive attitudes toward the implementation of WhatsApp Group as their teaching-learning media. The results also indicated that WhatsApp Group contributed significantly in helping the students to encourage meaningful learning among the learners, communicate, and interact actively. This learning media makes the information accessible from nearly any location with a mobile device or tablet. Both teacher and students have been looking to enrich the quality of their teaching and learning with the help of new and modern information technologies such as WhatsApp group.

From the interview, most students admitted that using WhatsApp Group Chat in their teaching-learning process made them easy to get the information, knowledge. They also could share the learning materials. The following extracts show the students' opinion about the advantages of this teaching-learning platform, as follows:

<i>DT</i>	... makes me easier to get the newest information, knowledge, and learning process.
<i>SMF</i>	I don't miss any information relating to assignment or another important information.
<i>RCN</i>	Based on my opinion, when I use whatsApp it's more benefit, we as students it's easy to communication each others even lecture that more effective, so we can get directly about the information.
<i>RS</i>	I can share everything that I know and every student can give a feedback
<i>NSM</i>	... we can sharing the material and also study not in the classroom but only using our smartphone.
<i>OI</i>	We can directly interact with lecturer and other friends via WhatsApp messenger. We also get the material which is uploaded by our lecturer and other friends.

Furthermore, several students argued that WhatsApp Group Chat is a simple learning tool and the best alternative to be implemented outside classroom. They could learn and access it anywhere. The following extracts describe their opinions, as follows:

<i>FRA</i>	I can learn anywhere...
<i>PAS</i>	Firstly, it's simple. We can learn anytime and everywhere... and we can more close to the other students and the lecturer.
<i>NSM</i> study not in the classroom but using our smartphone.
<i>AY</i>	It is a cheap platform. It can be reached by every students easily, whenever and wherever (based on the time limit given).
<i>IY</i>	In using whatsApp group, I can learn anytime and anywhere and the internet connection is faster.
<i>QC</i>	For me, student with many activity outside of the campus and somehow not that pay attention to e-learning platform like scela, i think using WA is the best alternative. I can do my test when i'm still in out of no wehere, or when i need to focus for my other activities.
<i>RR</i>	I can use it anywhere and everywhere and it is easy to use it in learning process.
<i>ES</i>	Easy for the user and more simple.

<i>DYA</i>	Not wasting my time and i can do something else during the process of learning.
<i>OI</i>	It can be accessed easily and anywhere.

Several students declared some problems using WhatsApp Group. They said that messages overloading, mistyping, and slow internet connection were the most problems occurred. The descriptions of their opinion can be seen in the following extracts:

<i>DT</i>	I have to scroll up and down to search the information or anything else in whatsapp group chat.
<i>SMF</i>	For me the factors is, time and internet connection.
<i>RS</i>	... there is difficulty when scrolling the flouding chat and getting the information.
<i>FRA</i>	... internet connection.
<i>PAS</i>	Connection problem.
<i>NSM</i>	My most problem are miss-typing and when I do typed my answer and already a lot of paragraphs then I accidentally deleted it. And sometimes the signal is do not support.
<i>AY</i>	... The internet connection problem is also affect the learning process.
<i>RR</i>	Maybe sometimes i have problems with the connection of the internet but over all everything is fine.
<i>DYA</i>	No internet connection and the messages are somehow overload.
<i>OI</i>	Message overloading when we send our assignment via WA. Then, Slow internet speed and unstable internet connection.

Accordingly, the findings seems possible to use WhatsApp group chat in the classroom since it potentially provides dynamic, effective, and cooperative learning environment with the help of internet and mobile devices. These findings are strengthened by several studies (Ajid, 2018; Bouhnik & Deshen, 2014; Çetinkaya & Sütçü, 2018; Gon & Rawekar, 2017). Thus, the potential of WhatsApp group chat to effect the teaching-learning process should be exploited.

IV. CONCLUSIONS AND SUGGESTIONS

In line with the fast development of technology, there is an influential transformation of learning styles from face-to-face learning or traditional learning to online learning. As perceived by the students, the implementation of WhatsApp platform is emphasized on certain number of advantages. The findings revealed that WhatsApp might serve as an effective means of language learning by the advanced level students. As such, this platform is aligned with the learner-centered approach to learning. The students admitted positive opinions that learning might also take place unconsciously and self-assisted. Their language learning is more effective due to its flexibility in the form of cost, place, time, and speed of learning. Hence, the teachers should try to find out the solutions or alternatives for the problems that occur during its implementation.

REFERENCES

- Ajid, L. H., et al. (2018). The use of whatsapp in collaborative learning to improve english teaching and learning process. *International Journal of Research Studies in Educational Technology*, 7(1), 29-35.
- Akpan, K. P. & Abe, E. (2017). Effectiveness of whatsapp as a collaborative tool for learning among undergraduate students in university of Uyo, Akwa Ibom State. *International Journal of Advanced Education and Research*, 2(5), 43-46.
- Barhoumi, C. (2015). The effectiveness of whatsapp mobile learning activities guided by activity theory on students' knowledge management. *Contemporary Educational Technology*, 6(3), 221-238.
- Bath, D. & Borke, J. (2010). *Getting started with blended learning*. Griffith: Griffith University Press.
- Bensalem, E. (2018). The impact of whatsapp on efl students' vocabulary learning. *Arab World English Journal (AWEJ)*, 9(1), 23-38. DOI: <https://dx.doi.org/10.24093/awej/vol9no1.2>
- Bouhnik, D. & Deshen, M. (2014). WhatsApp goes to school: mobile instant messaging between teachers and students. *Journal of Information Technology Education: Reserach*, 13, 217-231. Retrieved from: <http://www.jite.org/documents/Vol13/JITEv13ResearchP217-231Bouhnik0601.pdf>
- Çetinkaya L., & Sütçü, S. S. (2018). The effects of facebook and whatsapp on success in english vocabulary instruction. *Journal of Computer Assisted Learning*, 34, 504–514. <https://doi.org/10.1111/jcal.12255>
- Cheung, W. S. & Hew, K. F. (2011). Design and evaluation of two blended learning approaches: Lesson learned. *Australasian Journal of Educational Technology*, 27(8), 1319-1337.
- Eren, O. (2012). Students' attitudes towards using social networking in foreign language classes: A facebook example. *International Journal of Business and Social Science*, 3(20), pp. 288-294.
- Gon, S. & Rawekar, A. (2017). Effectivity of e-learning through whatsapp as a teaching-learning tool. *MVP Journal of Medical Sciences*, 4(1), 19-25. DOI: <http://doi.org/10.18311/mvpjms/2017/v4i1/8454>.
- Hamad, M. M. (2017). Using whatsapp to enhance students' learning of english language: Experience to share". *Higher Education Studies*, 7(4), 74-87. DOI: <http://doi.org/10.5539/hes.v7n4p74>.
- Liliia, K. & Gulnara, G. (2016). Mobile technologies in teaching english as a foreign language in higher education: A case study of using mobile application instagram. *Proceedings 9th International Conference of Education, Research and Innovation*. Seville, Spain, November 14th-16th, 2016.
- Low, P. & Warawudhi, R. (2016). Undergraduates' attitudes toward the use of facebook in fundamental English course. *International Journal of Information and Education Technology*, 6(12), pp. 934-939.
- Minalla, A. A. (2018). The effect of whatsapp chat group in enhancing fl learners' verbal interaction outside classroom contexts. *English Language Teaching*, 11(3), 1-7. DOI: <http://doi.org/10.5539/elt.v11n3p1>.
- Riduwan. (2008). *Belajar mudah penelitian untuk guru-karyawan dan peneliti pemula*. Bandung: Alfabeta.
- Sayan, H. (2016). Affecting higher students learning activity by using whatsapp. *European Journal of Research and Reflection in Educational Sciences*, 4(3), 88-93.
- Sharma, P. & Barrett, B. (2011). *Blended learning: Using technology in and beyond the language classroom*. Oxford: Macmillan.

About the Author

Complete Name : Fatimah Mulya Sari
Institution : Universitas Teknokrat Indonesia
Email Address : fatimah@teknokrat.ac.id
Education : Bachelor, English Department, Lampung University (2009-2013); Graduate Program, English Department, Sebelas Maret University (2013-2015)
Research Interests : Language Education, Critical Discourse Analysis, Classroom Management, Foreign Language Learning, Teaching Methods

CARTOON FILMS AN ITS CORRELATION TO STUDENTS VOCABULARY MASTERY

Dedy Subandowo¹, Meilani Ambariyani²
Muhammadiyah University of Metro^{1,2}
dedy.subandowo@ummetro.ac.id¹

ABSTRACT

This article discusses the influence of cartoon film in enhancing student's vocabulary mastery. The objective of this article is to know whether there is an influence of using cartoon film as an audio-visual media toward student's vocabulary mastery. The kind of this research is *quasi-experimental design*. The research was conducted at tenth grade of Islamic State High School (MAN) 1 Lampung Timur in 2018. The samples of this research were X IPA 1 and X IPS 2. The classes divided into two groups namely experiment (X.1) and control class (X.2) The sample was taken by using simple random sampling technique. In collecting the data, the researcher used pre-test and post-test. In addition, to analyze the data, the researcher used non-parametric formula. After analyzing the result of data by using non-parametric formula, the researcher gets the result of t_{ratio} is 2,55 and $t_{table} = 2,39$ on criterion 1. On criterion 2 shows $t_{count} = 2,55$ and $t_{table} = 1,67$. It means that $t_{count} > t_{table}$, then the criterion of t_{ratio} is H_a is accepted if the result depicts $t_{ratio} > t_{table}$. So, there is an effect of using cartoon film as an audio visual media toward students' vocabulary mastery at the tenth grade of MAN 1 Lampung Timur.

Keywords: *audio-visual media, cartoon film, vocabulary mastery*

I. INTRODUCTION

In communicating to many people, the communicators and communicants need to master one of languages used in the universe. English places as an international language which is used by many people to build right communication. A person who wants to use English to be his/her language must have many vocabularies.

Vocabulary is one of English aspects should be mastered like grammar, phonetic and morphology. Mc.Carthey, (2006:140) in his book stated that no matter how good the student learns grammar, no matter how fluently the learner speaks of L2 just cannot happen in any meaningful way. Besides, to understand English vocabularies and their meanings the learners must also know how the words work together in a right sentence. It can be said that in teaching vocabulary not only to give the meaning of the words but also to teach how the word works in sentence. According to John (2000: 16), vocabulary is knowledge of knowing the meanings of words and therefore the purpose of a vocabulary test is to find out whether the learners can match each word with a synonym, a dictionary-tape definition, or an equivalent word in their own language.

Students tend to forget the meaning of the word which have been taught or practiced before. It is commonly caused by complicated words and the meaning of the words itself. In common case, vocabulary is taught by memorizing words without any comprehension

to the words. For teachers, creating English teaching effectively and efficiently is not an easy job. They have to be able to organize teaching learning activities. They also should present the materials by using suitable teaching techniques or games and media. In addition, teaching learning process of English cannot be separated from the curriculum or syllabus. Based on Indonesian Education curriculum, the purpose of teaching English is students can master four English skills (listening, speaking, reading and writing). In fact, many students cannot state their ideas and opinion well since they are not accustomed to speak, feeling shy, hesitation and fear to make a mistake. Commonly it is caused by limited vocabulary they have.

The problem formulations in this research is “is there any influence of using cartoon films as an audio-visual media towards students’ vocabulary mastery at tenth grade of MAN 1 Lampung Timur in academic year 2017/2018. The purposes of this research is “to know whether there is influence of using cartoon films as an audio-visual media towards students’ vocabulary mastery at tenth grade of MAN 1 Lampung Timur in academic year 2017/2018. The benefits of this research are: to give some information about the effectiveness of using cartoon films as an audio-visual media towards students’ vocabulary mastery, the result of the research can be used to improve the quality of learning vocabulary, the researcher gets more knowledge about cartoon films as an audio-visual to be used in the research. This research can be used as reference for other researchers who want to conduct research about cartoon films as an audio-visual.

II. METHODS

This researcher used quantitative research in term of quasi experimental design. According to Margono (2005:105) quantitative research is the process using numeric data to find knowledge. In this research, the researcher applies pre-test and post-test control group design. The aim of quantitative research is to determine the relationship of independent variable and dependent variable in a population.

The sample is selected by taking two classes randomly. The first class is as an experimental class and the other one is as control class. In this research, the researcher takes two classes in at tenth grade of the students of MAN 1 Lampung Timur in academic year 2017/2018 as the sample. Bellow the steps done by the researcher:

1. Write classes in piece of paper.
2. The paper is rolled and then put into the glass.
3. Then, the glass is shaken until getting rolling of paper out.
4. The first roll of paper will be the subject of the research as experimental class.
5. The second roll of paper will be the subject of the research as control class.

Finally, the researcher finds X IPA 1 and X IPS 2 as the sample. Class X IPA 1 is as the experimental class and X IPS 2 as control class. Experimental class received treatment by using cartoon films as its media, and control class gets treatment through conventional media.

The aim of pre-test is to know the students' vocabulary mastery before the researcher giving treatment. The kind of test is multiple choices. The test consists of 25 questions. Each right item gets 4 (four) score and 0 (zero) when the answer is wrong. For the clearer formula is as follow: $N \times 4 = 100$.

Treatment is an activity in giving lesson by method, technique or some games. The treatment conducts after pre-test and before post-test to know the students accomplishment on vocabulary mastery. The researcher uses cartoon films as media to teach vocabulary for experimental class. For the control class, the researcher uses conventional media hat is white board and board marker only. The researcher wrote the list of vocabulary for the students and they look for the meaning on the dictionary. The researcher gives treatment for about 3 times for each class.

After giving treatment, the researcher gives the post test. The instrument of post-test is equivalent with pre-test. The researcher gives post-test in experimental and control class. The kind of test is multiple choices. The test consists of 25 questions. Each right item gets 4 (four) score and 0 (zero) when the answer is wrong. For the clearer formula is as follow: $N \times 4 = 100$

III. RESULTS AND DISCUSSION

This research has some results in every measurement. The first result is in validity of instrument. In this research, there are two instruments. They are the instrument of pre-test and post-test. In this research, the researcher uses content validity. The researcher uses the syllabus of English Subject at MAN 1 Lampung Timur to compare the content of those subjects material with the material have been taught to the students by the researcher. The result of the validity is 0,973 it means that the instrument items are valid.

The second is result of reliability of instrument. the researcher calculates the data to know the reliability. In this case the researcher uses Cronbach Alpha. The result shows that the reliability is 0,98. It means that the reliability is very high as it can be seen in the classification below: Very high (0,80 – 1,00), High (0,60 – 0,80), Sufficient (0,40 – 0,60), Low (0,20 – 0,40), and Very low (0,00 – 0,20).

Third, for measuring of the normality, the researcher uses non-parametric formula by using Liliefors method to measure the data is come from normal population or not. The data normality of the test accepted H_0 if $t_{count} < t_{tab}$ for the significance level 5% ($\alpha=0.05$) and also the significance level 1% ($\alpha=0.01$). on the table bellow it is obtained that L_o post test are lower than L_{tab} in the significance level of 5% ($\alpha = 0,05$). So, the hypothesis H_0 is accepted. It means that both of the samples in this research come from the population which have normality distribution.

Table 1. Normality Distribution Test

Test	Variable (X)	L _o	L _{tab}	Conclusion
			Significance level 5% ($\alpha = 0,05$)	
Pre-test	Class Exp.	0,045	0,161	Normal
	Class Cont.	0,10	0,161	Normal
Post-test	Class Exp.	0,068	0,161	Normal
	Class Cont.	0,015	0,161	Normal

Fourth is the result of measuring the homogeneity. The data homogeneity of the test accepted H_0 if $F_{ratio} < F_{table}$ for the significance level 10% ($\alpha=0.05$) and also the significance level 2% ($\alpha=0.01$). on the table below can be seen it is obtained that F_{ratio} of pre-test and post-test is lower than f_{tab} in significance level of 10% ($\alpha = 0,05$) and 2% ($\alpha = 0,01$). So that, the hypothesis H_0 is accepted, it means that both samples in this research come from the population which have the variance equality.

Table 2. The Result Data of Homogeneity Distribution Test

Test	F _{ratio}	F _{table}		Conclusion
		Significance level		
		10% ($\alpha = 0,05$)	2% ($\alpha = 0,01$)	
Pre-test	1,05	1,84	2,38	Homogenous
Post-test	1,67	1,84	2,38	Homogenous

Table 3. The Calculation Hypothesis of Pre-Test

Experiment Class	$n_1 = 30$	$\bar{x}_1 = 60,6$	$s_1^2 = 14,6$
Control Class	$n_2 = 30$	$\bar{x}_2 = 57,2$	$s_2^2 = 15,12$

Source: Table data results of Hypothesis Pre test

From the table above, $t_{count} = 0,883$ and t_{tab} on significance level 5%=2,00 it is gotten $t_{count} < t_{tab}$. So, H_0 is accepted and H_a is rejected. It shows that both classes have the same capability in the beginning.

The last is the hypothesis test of comparison. The data are shown below:

Variable	N	Average score	S ²	S	T _{ratio}	T _{table}	Conclusion
X ₁	30	66,8	14,96	3,87	2,55	1,67	Different
X ₂	30	58,53	11,57	3,40			

It is found that on criterion 1 shows $t_{\text{count}} = 2,55$ and $t_{\text{table}} = 2,39$. On criterion 2 shows $t_{\text{count}} = 2,55$ and $t_{\text{table}} = 1,67$. It means that $t_{\text{count}} > t_{\text{table}}$. So, H_a is accepted and it can be taken the conclusion that “cartoon films as an audio-visual is more effective than conventional method towards students’ vocabulary mastery at tenth grade of MAN 1 Lampung Timur in academic year 2017/2018”.

In this research, the researcher uses vocabulary on recount text which has some indicators such as adjective, adverb of manner, adverb of place and time, and verb 2 as the instrument of the research. Then, the average score of post-test from each class using cartoon films and conventional method was compared to find the differences of both scores. The result calculation shows that the score of post-test in experimental class is higher than control class. It also can be seen from the pre-test score which is compared with the post-test score.

Considering to the different result of the use of those media in this research, the researcher agrees with some theoretical reviews which are declared by some experts about cartoon films as media. The first is about cartoon films theory which comes from Harmer (2007: 118) states that cartoons can offer a wealth of possibilities. Teacher can ask the students to write description of one of a group of cartoons; their classmate then have guess which one it is. Then, in a fact the researcher found same fact about cartoon films. It can help students to move pictures which express a certain theme, idea, or story based on their interpretation of life by using moving drawings instead of real people and places provided the visual works in a positive way to enhance or supplement the language point.

The difference result of this research is showed that there is different achievement in mastering vocabularies. The result calculation shows that the score of post-test in experimental class is higher than control class. It also can be seen from the pre-test score which is compared with the post-test score. The result showed that there are the differences between pre-test and post-test ($\text{post-test} > \text{pre-test}$).

From the calculation above, $t_{\text{count}} = 0,883$ and t_{tab} on significance level $5\% = 2,00$ it is gotten $< t_{\text{count}} < t_{\text{tab}}$. So, H_0 is accepted and H_a is rejected.

Afterwards, from the calculation of post-test, it is shown that t_{count} is higher than t_{table} on significant level 5% is $2,55$. So, $t_{\text{count}} > t_{\text{table}}$ ($2,55 > 2,37$). It proves that H_0 is rejected and H_a is accepted. It can be said that there is different result between pre-test and post-test score in experimental class and control class. Moreover, the changing of students’ post-test score is higher than their post-test value, especially in experimental class which used

cartoon films as the learning media. It means that, cartoon films is more effective than conventional method to increase students' vocabulary mastery in daily vocabularies. The result of calculation indicates that the students' post-test result of experimental class is better than control class. It is seen when students' post-test score are compared to pre-test score. The result shows that there is significant difference between pre-test and post-test score (post-test > pre-test).

IV. CONCLUSION

In conclusion, learning process for the students which used cartoon films and conventional method is different. The researcher can state that by applying two methods could give the different result in mastering vocabulary. So, from the data of students' score on pre-test, treatment and post-test, it can be concluded that there is influence of using cartoon films as an audio-visual media towards students' vocabulary mastery at tenth grade of MAN 1 Lampung Timur in academic year 2017/2018.

REFERENCES

- Ahmad, Jazim. (2010). *Statistika lanjut*. Metro: Universitas Muhammadiyah Metro.
- Brown, H. D. (2004). *Language assessment: Principles and classroom practice*. San Francisco: Pearson Education
- Brown, H.D. (2001). *Teaching by principle: An interactive approach to language pedagogy. 2nd Ed.* New York: Addison Wesley. Longman, Inc.
- Budiyono. (2015). *Statistik untuk penelitian cetakan 4 edisi 2*. Surakarta. UNS Press.
- Daryanto. (2010). *Media pembelajaran peranannya sangat penting dalam mencapai tujuan pembelajaran*. Yogyakarta: Gava Media.
- Dewi, Vivit Kumalai. (2015). The use of cartoon films to improve students' skill in writing narrative texts. English Education Study Program. Sebelas Maret University Surakarta
- Djamarah & Zain (2010). *Strategi belajar mengajar*. Jakarta, Rineka Cipta
- Djiwandono, S.Patrisius Istiario. (2011). *Strategi belajar bahasa Inggris*. Indonesia: PT Malta Pritindo.
- Feri Kurniawan. (2016). The Use of audio visual media in teaching speaking. University of Syiah Kuala, Banda Aceh.
- Harmer, Jeremy. (2007). *The Practice English language teaching*. UK: Longman Group
- Hornby. (2000). Oxford Advanced Learners of Current English. New York: Oxford University Press. [Http://wyw1d.wordpress.com/2010/01/15/film-kartun-sebagai-mediapembelajaran/](http://wyw1d.wordpress.com/2010/01/15/film-kartun-sebagai-mediapembelajaran/).retrieved on January 2010.
- John, R. (2000). *Assesing vocabulary*. Cambridge: Cambridge University Press.
- Margono. (2005). *Metodologi penelitian Pendidikan*. Jakarta: Rineka Cipta.
- Michael Mc. Carthey.(2006). *Vocabulary in language teaching*. New York: Cambridge University Press.
- Reddy, R. J. (2008). *Methods of teaching*. New Delhi: S.B Nangia.
- Richards, J. C. & Renandya, W. A. (2002). *Methodology in language teaching: An anthology of current practice*. Cambridge: Cambridge University Press.
- Smaldino, E.Sharon, et al. (2002). *Instructional technology and media for learning*. USA: Pearson.
- Sudana, I Nyoman. (2013). Teaching vocabulary through flash cards to the fifth grade students of sd n 2 petulu in academic year 2012-2013. Denpasar
- Sudjana. (2005). *Metode statistika*. Bandung: Tarsito.

Sugiyono. (2013). *Metode penelitian kuantitatif kualitatif dan r&d*. Bandung: Alfabeta
Thornbury, S. 2002. *How to teach vocabulary*. United Kingdom: Pearson Education Limited.

About the authors

Author 1

Complete Name : Dedy Subandowo
Institution : Universitas Muhammadiyah Metro
Email Address : dedy.subandowo@ummetro.ac.id
Education : Master's Degree
Research Interest : Applied linguistics, sociolinguistics, language and media

Author 2

Complete Name : Meilani Ambariyani
Institution : Universitas Muhammadiyah Metro
Email Address : meilaniambariyani@gmail.com
Education : Bachelor Degree
Research Interest : Language and media, language teaching method

PROMOTING DIGITAL LEARNING TO ENHANCE STUDENT COMPETENCIES AS GLOBAL CITIZENS

Hermi Yanzi¹, Obby Taufik Hidayat²

Pancasila and Citizenship Education Study Program, University of Lampung^{1,2}
[sinarbanten1@yahoo.co.id¹](mailto:sinarbanten1@yahoo.co.id)

ABSTRACT

The core competencies of global citizens response are to be able to communicate, collaborate, critically thinking or problem solve in order to have creativity & innovation as competencies in the 21st century. Mastering English is one of the pivotal indicators to support the competency. However the capability to write and read in English is still low in Indonesia because English has not been implemented since childhood. This analysis explores the alternative solutions in mastering English development through the impact of the process of digital learning and online tools to enhance global citizen competence. It is thus, expand of the global digital network which enable individu to become active and informed global citizens.

Keywords: *competencies in the 21st Century, digital learning, global citizen*

1. INTRODUCTION

Analysis of the science and technology seeks to transform the traditional societies into modern societies which are expected to have innovativeness and competencies in responding to a risky future and the competition in the age of globalisation. Various education policies are rolled out by the government that encourage the students to have the competence to become global citizens. The competencies needed refer to the 21st century competencies whose designing and shaping the students having the ability to communicate, collaborate, critical thinking, and creativity (Boyatzis & Boyatzis, 2008). However, the hope is not as easy as we want. There are several facts that the most Indonesian people both in the upper class and the lower classes are weak in mastering English as a way of communicating across nations, so that it becomes a barrier factor for the 21st century competencies indicators as global citizens.

The Data states that Indonesia as a large country has a variety of languages, there are around 737 the regional languages or 11% of 6900 types of languages in the world (Gordon, 2005) and their communities favor their local language as everyday language rather than the foreign languages. To facilitate communication between the diversity of local languages, in 1928 during the second congress of youth oath, declared Indonesian as a national unifying language promoted by the government, the media, parents and schools, so that English was placed in a less important position among young generations (Lamb & Coleman, 2008). In contrast to other the Southeast Asian countries such as Singapore, Malaysia, the Philippines and the other countries in Africa, most students can speak English well because the application of English is done as early as possible and is used in a sustainable manner (Sudrajat, 2013).

The educational reform is carried out in Indonesia to improve quality standards. The reforms were promoted in schools as an effort to adjust the education industry revolution program 4.0 (digital) which has been implemented in several countries. The data shows around 7 billion people in the world as internet users, of which China, the United States and India are the countries with the highest number of internet users in the world (Internet World Statistics, 2016). So that the learning process oriented to textbooks in the classroom will no longer be used and begin to shift to the digital world. Inevitably, Indonesia as one of the big countries with a large population as internet users must be able to participate in the program. In millennial times, internet technology has become a part of the daily life patterns of students both in learning and playing. This can be used to implement digital learning that has a global network for social interaction towards activities that enable critical thinking skills and active involvement as informative global citizens (Harris, 2017).

This critical study reports the relevance of the digital learning process to the competence of the students in Indonesia in forming global citizens. Previous research revealed the impact of the digital learning including active in social media and other learning based on internet technology to improve communication in global networks (R. S.-A. J. of E. Technology & 2011, n.d. ; Verdugo & Belmonte, 2007). The objectives of this critical review are: first, to show how the impact of the digital learning process affects the English language skills of students in Indonesia; second, how the quality of English language skills affects the potential of students in responding to 21st century skills, which is one indicator of forming global citizens. To achieve this goal, two research questions were asked: first, the approach and ability of the teacher began to introduce digital learning and help students find learning difficulties ?; second, what type of digital learning instructional approach is what has a stronger influence on improving English language skills as an indicator of improving 21st century competency?

II. METHODS

This study is a critical study of the activities of reading and analyzing various articles with the aim of getting ideas, explanations, supporting data about the introduction of digital learning that enhances students' competence as Global citizens. In this learning context, the author wants to see the influence of digital learning on improving English language skills as one of the supporting indicators of global citizen competence based on 21st century competencies. The areas to be criticized explore the involvement of students in digital learning, digital communication skills respect each other and have integrity, motivation to learn English through digital learning, 21st century competencies and student competencies as global citizens.

III. RESULTS AND DISCUSSIONS

Student Involvement in Digital Learning

Currently, ICT is increasingly recognized in the wider community, it is important for the education community to move in the same direction in order to keep up with the technological advancements in the global era, education requires the incorporation of the new methods of the digital-based classrooms therefore digital competency training is needed right for teachers (Guillén-Gámez, Mayorga-Fernández, & Álvarez-García, 2018)

in digital teaching. This program is conducted to introduce digital learning models in Indonesian schools, namely those who have the ability to encourage this learning model based on the goal of school transformation in the global era. As reported the potential of information and communication technology (ICT) transforms learning in schools which indicates an increased interest in schools to collaborate both locally and globally (Austin, Smyth, Rickard, Quirk-Bolt, & Metcalfe, 2010).

These technology-based learning interventions have a positive impact on learning practices and student achievement outcomes, which have been proven by various previous studies (Niederhauser et al., 2018). The ICT-based learning can improve the quality of teaching, learning and school management and help achieve standards, this aspect of using digital technology is an important part of the effective integration, because the technology integration is more likely to have a positive impact on learning when it can be considered in integrated digital learning design (Livingstone, 2012). However, changes in education related to ICT are not possible without risk, so the teacher is expected to be able to take risks and engage in the practice of new (modern) teaching and learning (Howard, 2011). It is seen that digital learning is very complex especially with regard to attitudes or behavior of students who will experience social change. Therefore it is necessary to design a conceptual framework to investigate this phenomenon because learning that is integrated with technology is a dynamic social practice, in the system of social education (Howard & Thompson, 2016).

In the development of research in recent years, the digital technology supports the type of teaching and learning that is more effective in changing the teaching and learning process that is not digital or manual, but the digital learning is still trying to gradually change the learning transformation (Greenhow, Robelia, & Hughes, 2009). In this case, teaching is not effective without using appropriate ICT resources for student learning facilities (Ertmer & Ottenbreit-Leftwich, 2010) because the learning models that use ICT are more interesting and not boring. On one side of online technology such as the deep digital learning environment, digital video, management tools for open source courses can develop students aware of being part of their community and citizens who have global insight (Warren, Dondlinger, & Barab, 2008). In harmony with the internet being a tool in the world of education that works in expanding to a local community to work in a global community, it also opens opportunities for students unable to explore the world due to cost constraints (Harris, 2017; Livingstone, 2012) which enables them to surf the world virtual without time and space. Such conditions will create an international communication system to train students to collaborate in digital learning.

Online Communication Process

In digital learning innovations can be promoted if there is a comprehensive curriculum vision that facilitates the development of interdisciplinary learning experiences that enhance authentic learning, problem solving activities, development of critical thinking skills and collaboration (Moltó, Sancho, & Domingo, n.d.). This means that communication skills are needed so that the goals are achieved well, especially in the global scope. Many students in Indonesia have good cognitive abilities in developing experiences between learning disciplines, but if it goes to the global scope of English language skills it is still a challenge to communicate across nations well. The process of

digital communication has introduced a lot of vocabulary in English to be understood by students. One communication tool through computer media (computer mediated communication) that is preferred by students is social media such as Facebook for communication in their groups (Harris, 2017). Facebook (social media) in the field of digital communication is a part of everyday lifestyle that breaks through space and time in interacting, using Facebook communication is considered more attractive because it has various types of communication features (Virginia, Keywords, & Virginia, 2012). We cannot deny students everyday communication through computer media related to the internet is a common tragedy, because the internet is a common property that benefits everyone in a social system (Standards, 2017). So it needs to be utilized in creating good communication for everyone.

Modern network infrastructure is a complex system, which consists of the heterogeneous technology, each with a different ownership configuration and the interface management (Rotsos et al., 2017). The emergence of technology in recent years, the advancement of internet protocols, and computer systems have made communication between different devices easier than ever and enriched human activities and experiences (Saeid, Rezvan, & Barekataan, 2018). For this reason, it is important for students to learn communication strategies that must be applied in the digital world so that cross-nation communication runs smoothly. Not a few ideas, the concepts, and the thoughts of Indonesian students are brilliant, but the challenge is the lack of communication skills, especially in mastering English. Furthermore any ideas that we have cannot be conveyed clearly. Therefore digital learning is present in introducing English in its learning features, which inevitably requires students to be able to translate these features. Thus, students who have routinely used digital learning will make it easy to remember English vocabulary which in the end by improving their global communication skills will be more digital literate.

Digital Literacy

In supporting an effective digital learning atmosphere, the efforts are needed to encourage digital literacy students. Not just getting knowledge about the digital domain but deep understanding like one of the ways to solve problems in the digital world. In essence digital literacy requires more than just the ability to use digital software and devices, it includes a wide variety of complex cognitive, motor skills, sociological skills, emotional skills, which are all needed by users to the function effectively in a digital environment (Eshet, 2004). According to the opinion above we can analyze that mastery of the digital material content must be accompanied by mastery of other aspects that must be raised from the internal factors of the students themselves. Another understanding of digital literacy is the ability to understand information and more importantly to evaluate interpreting and integrating information in various formats that can be provided by computers (Pool, 1997). Therefore, it takes expertise to read the instruction format in the digital learning process so that it is not misinterpreted in digital literacy.

As the Internet spreads to an ever increasing part of the population and as online services begin to absorb more and more parts of people's daily lives, nuanced measures of Internet use will be increasingly important for research on the social implications of information technology (Hargittai, 2009). The expansion of the Internet and other digital communication platforms has opened up the new dimensions and the opportunities for

learning through knowledge sharing groups, discussion groups, knowledge communities, chat rooms, and many other forms of collaborative learning (Alkali & Amichai-Hamburger, 2004). Those who are classified as digital literacy engage in interactions that are not limited to space and time. They are involved in the global network in communicating so that thinking is more open and follows the progress of the world that is always moving dynamically. The effective education is needed to foster digital literacy. Education, like other social sectors, quickly adopted electronic means. But the evolution of electronic devices for education has gone hand in hand, and to a certain extent driven by paradigm shifts in approaches to learning and teaching (Martin, 2005)

Information and Communication Technology in Education

The development of information and communication technology (ICT) provides benefits to improve efficiency, productivity, and collaboration between people in the world of education. It appears that in this era ICT is one of the component needed to meet market demand and face all kinds of challenges in the education field. ICT are used because they have a positive contribution to learning in schools and to be more effective, this requires the conscious effort of all people in the school ecosystem, namely principals, teachers, parents and students to make everything work well according to its role (Eng, 2005) Schools that approach the ICT integration model, in the process of changing teachers learn the skills and applications of new technologies, and explore new pedagogical approaches to the planning and delivery of content knowledge in new contexts (Yuen, Law, & Wong, 2003)

In the application and integration of ICT, it is not as easy as we imagine, it will certainly meet a number of challenges, especially in developing countries such as Indonesia. This is because the facilities and experts in ICT are still lacking. In addition, understanding the concept of integration in schools is still lacking in its application. Furthermore, the challenges faced are due to the high cost of obtaining, installing, operating, maintaining and replacing ICT in schools. although it is potentially very important, the integration of ICT into teaching is still in the growth stage (Sarkar, 2012) and needs attention from the government and other stakeholders. Integration of ICT in teaching and learning is not only related to the introduction of new hardware and software, but both trainers and students must adopt new roles, and change their ICT behavior and ways of teaching and learning (C. Technology, 2007). We can analyze that the integration of ICT in education requires soft skills that support effective learning in schools especially with regard to our attitude to applying ICT in learning schools.

Rapid changes in information and communication technology globally are very fast. It seems that we need to adjust and follow the ICT applied in the education curriculum in the schools in Indonesia with the development of ICT in schools universally. More precisely, this is evidence of global, social and technological change that has contributed to the 'new age' in which we all live. Furthermore, it is very important that educators be aware and capable of managing at the classroom level of impact resulting from social, cultural, political and economic trends and education policies and programs (Jamieson-proctor & Burnett, 2006).

Social Media for Digital Learning

The use of social media has become a part of life for almost all millennial era students in all countries. We cannot deny that social media is a new forum for interacting between friends and connecting people who are far away because they are interwoven with virtual communication. Lately social media like Facebook, YouTube and Instagram have become familiar among students in Indonesia. Students' interest in social media is because the features offered are always innovating and updating. So that students use social media for several purposes such as expressing their thoughts (66.7%), sharing links (44%), and being silent readers (11%) (Pradita, 2014). If social media is used for their full potential, I believe they will make public relations practiced more global, strategic, two-way and interactive, symmetrical or dialogical, and socially responsible (Grunig, 2009). The form of social media presented in Indonesia is social media that is also used universally. So that mostly from social media, the service uses English. Inevitably students who want to keep abreast of social media developments will find out the meaning of the language of the features and information delivered in English. We can analyze that indirectly they have added English vocabulary by frequently using social media services.

Social media sites such as blogs, microblogs, video sharing sites, electronic forums, and other websites are used to maintain public relations (Bowen, 2013). Then clarified social media can be based on characteristics: collaborative projects, blogs, content communities, social networking sites, virtual game worlds, and virtual social worlds (Kaplan & Haenlein, 2010) as Active social media users in increasing their network in the global domain will continue to improve communication methods, which is to increase English vocabulary to maintain good relations across countries. In addition, there are efforts to follow up on applications on social media, students will always want to translate English language to understand their intentions so that they can be involved in it on an ongoing basis. Therefore learning English by means of media like like through social media will make it easier to digest and remember. In essence, social media is active and promotes active learning for students, many scholars argue for the integration of social media as well as educational tools (Tess, 2013). It is necessary to revitalize social media to provide many benefits, one of which is communicating in English, both reading, writing and listening. Rather than only being used as an entertainment medium regardless of the use of social media.

Competence of Students to Become Global Citizens

A learning approach that can shape the students into global citizenship should be applied in Indonesia for involvement and participation in world issues. This needs to be supported by the Indonesian government to continue to improve education that is oriented to competencies to face global challenges. Many leaders and organizations in the world in the past decade have been and continue to work in preparing academic graduates who have mastery and critical thinking skills, communication, technology literacy, and collaboration needed for success, participation, achievement and competition in global communication (Guo, 2014) Therefore we need to prepare our students in facing real life and the challenges of a world that continues to move dynamically (Jooste & Heleta, 2017). One moving approach is to prepare students as global citizens with the 21st

century competency approach which includes critical thinking skills, creativity, collaboration & communication, leadership, and global awareness (Soland, Hamilton, & Stecher, 2013).

Students and Teachers in the 21st Century Competency Development Process

In achieving the expected 21st-century competencies, teachers are needed as facilitators who should be able to develop and maintain student learning abilities and help them become motivated learners of all time (Attard et al., 2010; Suryadi et.al., 2016) that lead to the 21st century competences. Teachers also need to keep up with the progress of the times that continue to move dynamically, as supporting the competencies of students to shape them into global citizens. Therefore the aim of forming students in Indonesia to become global citizens should be done so that they are ready to compete in the world. Further becoming global citizens view their involvement locally, nationally, and internationally as critical, knowledgeable, educated on world issues by demonstrating social responsibility and the defense of oppressed people (Hanson, 2010). With this context, international-minded education must be applied to students in supporting the competence of the 21st century in the global era. Education that views global citizens as follows: people involved in activism; open-minded and accept other cultures in a respectful, tolerant and non-judgmental way; pursue knowledge and seek understanding; feel part of the human community; and having awareness, which includes not only self-awareness, but also awareness of the interconnection between local and global problems and the impact of one's actions in the world (Hendershot, Education, & 2009, n.d.). Therefore, global awareness needs to be fostered to make students sensitive to the position of their lives as citizens of the world.

Global Citizen Education

Every student needs initial awareness (global awareness) that he lives in diversity, lives in general beliefs and lives in different cultural values. So that students can benefit from their life experiences before doing global learning. Global awareness refers to the knowledge of globalization and the issues that are generated and the problems that affect the lives of everyone in an understanding of the interrelationships and interdependencies in this world. Therefore global learning is needed as a student-centered activity where students from different cultures use technology to improve their global perspective while they remain in their home countries (Kay & Glyn, 2008). This allows students to see the diversity that exists in this world with mutual respect and tolerance. Therefore in the current global environment, social study teachers have the opportunity to broaden their students' vision of the role of citizenship in developing democratic understanding by adopting various perspectives on citizenship (Rapoport, 2005). Previous research has suggested that teacher preparation should facilitate teachers' understanding of their beliefs about race, class, culture and other human diversity. It must also pay attention to how fragile and tentative the teacher's professional identity, and professional practice, is during early teacher education (Clarke & Drudy, 2006). Seen in global citizen education, the goal is to live harmoniously in the midst of diversity.

IV. CONCLUSIONS

The introduction of digital learning is an important implication as an effective discussion in responding to the progress of the era, especially in the era of industrial revolution 4.0 (digital era). This digital learning process benefits students to have the ability to find solutions to international problems as a form of active participation that follows the development of the world. The 21st century competency strives to be a reference for students to meet the standards of becoming global citizens. This is because the 21st century competency content such as collaborative expertise, communication, critical thinking, creativity, global sensitivity and leadership expertise can elaborate on the capacity of students to be actively involved as good global citizens. Good English language skills need to be possessed by students as one of the supporting indicators students can implement the 21st century competencies because students will engage in wider networking between nations. Therefore digital learning is here to help students improve their English skills while supporting students with the 21st century competencies.

Furthermore, this critical study reveals that digital learning demonstrates internet technology as a valuable source of information and communication for students to learn and play digital games (López, 2010). Students will explore and translate various kinds of instructions or commands, new information, and share knowledge in the digital world atmosphere that more often uses English as the language of instruction. So that these activities can increase their English vocabulary and understand basic linguistic structures that make students more active in speaking and writing English (Verdugo & Belmonte, 2007). Then more than that digital learning allows students to add to their social networking from the interaction of small scope to a wider scope because internet technology is not limited to space and time. In the end we can conclude digital learning can help students improve their English language skills and global networking as supporting the 21st century competency supporting indicators to shape them into smart, productive and participatory global citizens.

REFERENCES

- Alkali, Y. E., & Amichai-Hamburger, Y. (2004). Experiments in Digital Literacy. *CyberPsychology & Behavior*, 7(4), 421–429. <https://doi.org/10.1089/cpb.2004.7.421>
- Austin, R., Smyth, J., Rickard, A., Quirk-Bolt, N., & Metcalfe, N. (2010). Collaborative digital learning in schools: Teacher perceptions of purpose and effectiveness. *Technology, Pedagogy and Education*, 19(3), 327–343. <https://doi.org/10.1080/1475939X.2010.513765>
- Bowen, S. A. (2013). Using Classic Social Media Cases to Distill Ethical Guidelines for Digital Engagement. *Journal of Mass Media Ethics: Exploring Questions of Media Morality*, 28(2), 119–133. <https://doi.org/10.1080/08900523.2013.793523>
- Boyatzis, R., & Boyatzis, R. E. (2008). Competencies in the 21st century. *Journal of Management Development*, 27(1), 5–12. <https://doi.org/10.1108/02621710810840730>
- Clarke, M., & Drudy, S. (2006). Teaching for diversity, social justice and global awareness. *European Journal of Teacher Education*, 29(3), 371–386. <https://doi.org/10.1080/02619760600795239>

- Eng, T. S. (2005). The impact of ICT on learning : A review of research, *6*(5), 635–650.
- Ertmer, P. A., & Ottenbreit-Leftwich, A. T. (2010). Teacher technology change: How knowledge, confidence, beliefs, and culture intersect. *Journal of Research on Technology in Education*, *42*(3), 255–284. <https://doi.org/10.1080/15391523.2010.10782551>
- Greenhow, C., Robelia, B., & Hughes, J. E. (2009). Learning, Teaching, and Scholarship in a Digital Age: Web 2.0 and Classroom Research: What Path Should We Take Now? *Educational Researcher*, *38*(4), 246–259. <https://doi.org/10.3102/0013189X09336671>
- Grunig, J. E. (2009). Paradigms of global public relations in an age of digitalisation. *PRism*, *6*(2), 1–19. Retrieved from http://praxis.massey.ac.nz/prism_online_journ.html
- Guillén-Gámez, F. D., Mayorga-Fernández, M. J., & Álvarez-García, F. J. (2018). A Study on the Actual Use of Digital Competence in the Practicum of Education Degree. *Technology, Knowledge and Learning*, (0123456789), 1–18. <https://doi.org/10.1007/S10758-018-9390-Z>
- Guo, L. (2014). Preparing Teachers to Educate for 21 st Century Global Citizenship: Envisioning and Enacting. *Journal of Global Citizenship & Equity Education*, *4*(1), 1–23.
- Hanson, L. (2010). and the Internationalization of Curriculum A Study of Transformative Potential, 70–88.
- Hargittai, E. (2009). An update on survey measures of web-oriented digital literacy. *Social Science Computer Review*, *27*(1), 130–137. <https://doi.org/10.1177/0894439308318213>
- Harris, U. S. (2017). Virtual Partnerships: Engaging Students in E-service Learning Using Computer-mediated Communication. *Asia Pacific Media Educator*, *27*(1), 103–117. <https://doi.org/10.1177/1326365X17701792>
- Hendershot, K., Education, J. S.-C. I. in C., & 2009, undefined. (n.d.). Study Abroad and Development of Global Citizen Identity and Cosmopolitan Ideals in Undergraduates. *ERIC*. Retrieved from <https://eric.ed.gov/?id=EJ879768>
- Howard, S. K. (2011). Affect and acceptability: Exploring teachers' technology-related risk perceptions. *Educational Media International*, *48*(4), 261–272. <https://doi.org/10.1080/09523987.2011.632275>
- Howard, S. K., & Thompson, K. (2016). Seeing the system: Dynamics and complexity of technology integration in secondary schools. *Education and Information Technologies*, *21*(6), 1877–1894. <https://doi.org/10.1007/s10639-015-9424-2>
- Jamieson-proctor, R. M., & Burnett, P. C. (2006). ICT integration and teachers' confidence in using ICT for teaching and learning in Queensland state schools Glenn Finger and Glenice Watson, *22*(4), 511–530.
- Jooste, N., & Heleta, S. (2017). Global Citizenship Versus Globally Competent Graduates: A Critical View From the South. *Journal of Studies in International Education*, *21*(1), 39–51. <https://doi.org/10.1177/1028315316637341>
- Kaplan, A. M., & Haenlein, M. (2010). Users of the world , unite ! The challenges and opportunities of Social Media. <https://doi.org/10.1016/j.bushor.2009.09.003>
- Kay, L., & Glyn, M. (2008). Developing Global Awareness and Responsible World Citizenship With Global Learning, *194*(January 2007), 11–23.
- Lamb, M., & Coleman, H. (2008). Literacy in English and the transformation of self and society in Post-Soeharto Indonesia. *International Journal of Bilingual Education and Bilingualism*, *11*(2), 189–205. <https://doi.org/10.2167/beb493.0>
- Livingstone, S. (2012). Critical reflections on the benefits of ICT in education. *Oxford Review of Education*, *38*(1), 9–24. <https://doi.org/10.1080/03054985.2011.577938>
- López, O. S. (2010). The Digital Learning Classroom: Improving English Language Learners' academic success in mathematics and reading using interactive

- whiteboard technology. *Computers and Education*, 54(4), 901–915. <https://doi.org/10.1016/j.compedu.2009.09.019>
- Martin, A. (2005). DigEuLit European framework for digital literacy: a progress report. *Journal of ELiteracy*, 2, 130–266. Retrieved from http://www.jelit.org/65/01/JeLit_Paper_31.pdf?utm_source=twitterfeed&utm_medium=twitter
- Moltó, O., Sancho, J. M., & Domingo, L. (n.d.). No Title.
- Niederhauser, D. S., Howard, S. K., Voogt, J., Joke, Douglas, A., Agyei, D., Laferriere, T., ... Cox, M. J. (2018). Sustainability and Scalability in Educational Technology Initiatives: Research-Informed Practice. *Technology, Knowledge and Learning*. <https://doi.org/10.1007/s10758-018-9382-z>
- No Title. (2004), 93–106.
- Pool, C. R. (1997). A New Digital Literacy A Conversation with Paul Gilster. *Educational Leadership*, 55(3), 6–11. Retrieved from <http://namodemello.com.br/pdf/tendencias/tecnolnocurric.pdf>
- Pradita, I. (2014). Enhancing Learning Through Social Media. *Disaster Medicine and Public Health Preparedness*, 8(06), 576. <https://doi.org/10.1017/dmp.2014.147>
- Rapoport, A. (2005). The Journal of Social Studies Research. *The Journal of Social Studies Research*, 33(1), 91–113.
- Rotsos, C., King, D., Farshad, A., Bird, J., Fawcett, L., Georgalas, N., ... Hutchison, D. (2017). Computer Standards & Interfaces Network service orchestration standardization : A technology survey, 54(December 2016), 203–215.
- Saeid, M., Rezvan, M., & Barekatin, M. (2018). Machine learning for internet of things data analysis : a survey, 4(October 2017), 161–175.
- Sarkar, S. (2012). The Role of Information and Communication Technology (ICT) in Higher Education for the 21st Century, 1(1), 30–41.
- Soland, J., Hamilton, L. S., & Stecher, B. M. (2013). Measuring 21st century competencies: Guidance for educators. *Asia Society Global Cities Education Network Report*, (November), 68. Retrieved from <http://asiasociety.org/files/gcen-measuring21cskills.pdf>
- Standards, C. (2017). crossmark, 50(March 2016), 76–82.
- Sudrajat, D. (2013). Studi Tentang Pelaksanaan Pengajaran Bahasa Inggris Di Sd Kota Tenggara. *Cendekia*, 9(1), 13–24. <https://doi.org/http://dx.doi.org/10.30957/cendekia.v9i1.49>
- Technology, C. (2007). New technologies for teaching and learning : Challenges for higher learning institutions in developing countries A . S . Sife , E . T . Lwoga and C . Sanga, 3(2), 57–67.
- Technology, R. S.-A. J. of E., & 2011, undefined. (n.d.). Can Web 2.0 technology assist college students in learning English writing? Integrating Facebook and peer assessment with blended learning. *Ascilite.Org.Au*. Retrieved from <http://ascilite.org.au/ajet/submission/index.php/AJET/article/view/934>
- Tess, P. A. (2013). Computers in Human Behavior The role of social media in higher education classes (real and virtual) – A literature review, 29, 60–68.
- Verdugo, D. R., & Belmonte, I. A. (2007). Using digital stories to improve listening comprehension with Spanish young learners of English. Retrieved from https://scholarspace.manoa.hawaii.edu/bitstream/10125/44090/1/11_01_ramirez.pdf
- Virginia, A., Keywords, K. K., & Virginia, A. (2012). pada Era Media Baru : Studi Kasus Penggunaan Facebook oleh Digital Natives *, 1, 77–85.
- Warren, S. J., Dondlinger, M. J., & Barab, S. A. (2008). A muve towards pbl writing: Effects of a digital learning environment designed to improve elementary student writing. *Journal of Research on Technology in Education*, 41(1), 113–140. <https://doi.org/10.1080/15391523.2008.10782525>
- Yuen, A. H. K., Law, N., & Wong, K. C. (2003). ICT implementation and school

leadership Case studies of ICT integration in teaching and learning.
<https://doi.org/10.1108/09578230310464666>

ETHNIC SNAKE GAME: A STUDY ON THE USE OF MULTIMEDIA IN SPEAKING CLASS FOR ELECTRICAL ENGINEERING STUDENTS

Lulud Oktaviani

Universitas Teknokrat Indonesia
lulud_oktaviani@teknokrat.ac.id

ABSTRACT

Using technology in teaching and learning process can give some benefits to both lecturer and students. Besides, the material delivered can be more attractive and stimulating the students' enthusiasm. Anyhow, there were still fewer technology usage in teaching and learning in speaking class as the researcher did a preliminary study (questionnaire) in Universitas Muhammadiyah Malang (UMM). The preliminary study showed that 64% students said using teaching media increases their interest in speaking class and 63% students said it helps them in understanding the material. Related to this preliminary study, this study was aimed at applying a multimedia-based medium, Ethnic Snake Game, in speaking class for Electrical Engineering students in UMM. Answering the students' need, the researcher wanted to use a multimedia-based medium, Ethnic Snake Game, in speaking class for Electrical Engineering students in UMM. Thus, this research belongs to descriptive research. In using this multimedia-based medium, the lecturer found that 79% students could understand the material easily and 63% students said the speaking class was fun.

Keywords: *multimedia, teaching media, speaking class*

I. INTRODUCTION

Using technology in teaching and learning process can give some benefits to both lecturer and students. Besides, the material delivered can be more attractive and stimulating the students' enthusiasm. Thus, lecturers are appealed to use technology or Computer Assisted Language Learning (CALL) in education aspect in order to attract students' attention, maximize their potential, and expand what they need to learn. It is in line with Smaldino, Lowther, & Russel (2008: 5) who state that CALL, however, will help students learn beyond text book, not limited to the confines of the classroom, and help them achieve their highest potential regardless of their innate abilities. So, lecturers are demanded to choose which technology suits their ability and mastery. Preparing technology in teaching is not easy and takes time, but it is more long lasting than paper or other conventional teaching. Besides, it also can be used again and again and easier to carry around.

Apparently, using multimedia in teaching English skills (Reading, Listening, Writing, and Speaking) is developing among the teachers or lecturers since it is also one of requirement from government. It is because the teaching and learning activities become more effective and interesting for students. In fact, the variation of teaching media is limited; the lecturers mostly only use power point or video for teaching reading, listening, writing, and speaking.

Fortunately, these monotonous media usage stimulate some researchers to create good and interesting media.

Based on the explanation above, the researcher decided to use ethnic snake game which is a multimedia-based medium (computer-based) which contains local wisdom such as some pictures about traditional clothes or foods in order to promote speaking skill for electrical engineering students at Universitas Muhammadiyah Malang (UMM). Ethnic snake game is adapted from snakes and ladders game board which is modified and combined with technology. Originally, snakes and ladder is found in a book from India and played by using numbers that was written on the board, pawns and dice (Avedon, 2010). Recently, it has been modified regarding the material and rules. For example in teaching and learning process, teacher or lecturer will modify the board depending on what English skill or content he/she will teach.

UMM, especially electrical engineering major is chosen by the researcher because the researcher has become an English for Specific Purposes (ESP) lecturer in this institution since 2013. Besides concerning the accessibility, the researcher is also aware that mostly the students are boys and they have low motivation in learning English since English is not their main major. It is in line with Kissau and Salas (2013) that boys have less motivation in learning another language (L2) compared to girls. So, by exposing local wisdom in the class, they are expected to be more interested because the materials are related with their culture, their environment, and their social life (Hakim, 2015).

Moreover, the preliminary survey and book observation were conducted by the researcher by collecting the data from book analysis, giving questionnaire to students. Regarding the instruments, the researcher used questionnaire. Based on the preliminary survey in the form of questionnaire and book observation done by the researcher on December 19, 2015, there are some reasons why the researcher proposes a multimedia-based medium as an alternative medium for teaching ESP in UMM. First, the speaking activities in the book used by the ESP lecturer entitled English for Electrical Engineering (2014) are monotonous. The activities are mostly individual performance, group presentation, role-play, and making a dialogue. Second, ESP program in UMM is a model for other schools or universities that want to create the same program. It is proven by some universities or school who visited Language Center (LC) UMM to have ESP study visit because some of them do not have an ESP program yet and some of them want to know about the syllabus, teaching and learning process, media used, and many more. The list of school and university are provided in the table below:

No.	Name of the Institutions	Date of Study Visit
1.	University Muhammadiyah of Purwokerto	December 20, 2011
2.	MAN Bangil	January 24, 2012
3.	University Muhammadiyah of Jember	April 7, 2012
4.	Politeknik Negeri Batam	April 8, 2014
5.	University of Surakarta	January 24, 2015
6.	University Muhammadiyah of Yogyakarta	February 4, 2015
7.	SMAN 2 Mojokerto	October 13, 2015

Table 1. Study Visit to LC of UMM

Third, based on the questionnaires which given to the students showed that most of them wanted to have various activities in learning speaking. The result on how they think about teaching media in speaking class is presented in the table below.

Table 2. Students' Opinion about Speaking Class

Statements	Always	%	Sometimes	%	Never	%
Does ESP Lecturer use teaching media in speaking class?	39	38.6	52	51.5	8	7.92
In your opinion, is the use of teaching media important in a class?	90	89.1	11	10.9	0	0
Does teaching media increase your interest in speaking?	65	64.4	32	31.7	3	2.97
Does teaching media help you in understanding the material?	64	63.4	36	35.6	1	0.99
Does the lecturer use computer-based media in the class?	1	0.99	35	34.7	64	63.4
In your opinion, is speaking skill important for your career in the future?	95	94.1	3	2.97	1	0.99

From the table above, 52 out of 101 students said that the lecturer sometimes used teaching media in a class whereas most of them (90 students) thought that teaching media was important in a class. Moreover, more than a half of them said teaching media will increase their interest in the material and do help them in understanding the material. In contrast, 64% students said the lecturer never used computer-based media in teaching speaking. However, only 35% students said that their lecturer sometimes used computer-based media in a class. Hopefully, by using a multimedia-based medium, the researcher can contribute to make LC UMM become a better model for others, especially in the form of media used for teaching.

Therefore, the researcher conducted a study related to multimedia usage to help students in speaking by applying Ethnic Snake Game which does not always concern with abstract thinking and monotonous lessons. As Brown (2007: 104-105) stated that although adult learners have superior cognitive ability, they will still find difficulties if the teaching and learning activities exposed too many abstract things, longer attention spans for material which are not interesting, and a not varied sensory input. However, in this medium the researcher tries to present an interesting medium which combine game, picture, and animation. Stemler (1997) said that high quality multimedia development should consist of instructional design, screen design, interaction and feedback, navigation, learner control, color, graphics, animation, audio, and video.

By using multimedia, the researcher does not only try to make interesting teaching and learning activities but also introducing and emphasizing students' character through technology by using local wisdom understanding. Thus, the researcher chooses a medium consisted some animation characters who wear traditional clothes of Indonesia, some famous places, and some traditional foods. According to Meliono (2011), local wisdom is a behavior or attitude based on compilation of cultures that at last produces certain works. So, it is expected that through technology and English the students familiarize themselves about the culture or place or object around them by applying the culture, visiting the places, and promoting the object such as *batik*, traditional clothes or foods, etc. Besides, these students are the prospective generation who will likely take care of the culture so that its sustainability may be preserved. It is in line with Susanti (2013) that teaching by inserting local wisdom can strengthen students' foundation of philosophy or character which suit the values on the wisdom of the culture around them.

Furthermore, the researcher has own interest in English teaching speaking since it is productive skill and the target of speaking is to express the idea freely and spontaneously (Harmer, 2007). Moreover, Ur (2012: 117) stated that among four language competence skills (listening, speaking, reading, and writing), speaking is the most important skill to be learnt. Besides, Brown and Yule (1983) stated that it is often considered one of the most difficult aspects of language learning. It is because they need to combine the grammars, vocabularies, the pronunciation, and also the culture they have learnt together as Nunan (1999) stated that the speaker needs communicative competence which includes not only linguistic competence but also a range of other sociolinguistic and conversational skills. In fact, it is true that students at university level hardly speak and express their idea spontaneously although they have learnt the language or skill since elementary school or junior high school. Hopefully by using a multimedia, it can help the students stimulate and integrate their understanding into the activities to train the spontaneously speaking.

II. METHODS

The research method used in this study is descriptive since the researcher obtained the data from giving questionnaire and conducting teaching in speaking class of Electrical Engineering students at UMM. It is in line with Ary (2006: 31), qualitative research is used to seek an understanding about a phenomenon by focusing on the picture rather than breaking it down into variables. The goal is a holistic picture and depth of understanding, rather than a numeric analysis of data.

For the sample of the research, the researcher worked with the 1st semester students from Electrical Engineering major in UMM, East Java, class C. The class was selected because the researcher taught the class. Thus, the researcher had full access to the class. The multimedia is chosen because it consists of describing people topic which the topic is stated in the syllabus as one of the topics that must be taught in the first semester.

III. RESULTS AND DISCUSSIONS

The researcher used the Ethnic Snake Game to teach speaking in the 7th meeting for Electrical Engineering students on December 26th, 2016. The teaching and learning process

included pre-teaching, whilst-teaching, and post-teaching activities. The detailed activities are presented as follows:

Pre-teaching Activities

1. Greeted the students and checked the students' attendance by calling students' name one by one.
2. Told the students about the objectives of the material.
3. Showed the students the Ethnic Snake Game multimedia that was going to be used.



Figure 1. The first appearance of the multimedia game



Figure 2. The first appearance of unit selection



Figure 3. The example of first appearance in unit 1

4. Chose *warm-up activity* menu or button to start the class and asked the students to mention adjectives related to the pictures.



Figure 4. The example of warm-up activity (first option)



Figure 5. The example of warm-up activity (second option)

5. Asked students' background of knowledge on the topic that will be discussed, such as: Have you described someone appearance before? What tenses do you use in describing person?

Whilst-teaching Activities

6. Explained the material and showed the example by using Ethnic Snake Game.

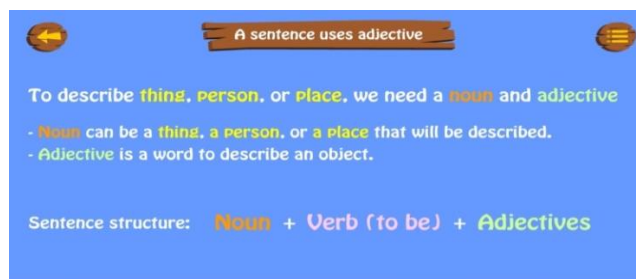

Figure 6. How to make a sentence uses adjective



Figure 7. One example of adjective group



Figure 8. An abbreviation for order of adjectives



Figure 9. The example of a sentence which uses four adjectives

7. Asked the students to create their own sentences using several adjectives.
8. After the students had understood, the lecturer explained about the rules in playing a snake game.

How to play this game is almost the same like snake and ladder game that are some pawn, dice, and board. The students' pawn will move based on the number after rolling the dice. If they are lucky, they get number on the board with a question and

they need to speak based on the instruction shown within limited time. However, if they cannot speak clearly according to the lecturer, their pawn will go back two steps. The worst is unlucky number which they will get number on the board with skip turn caption, go back two steps, etc. Finally, the winner is the fastest student or group to reach finish line.

9. Played the game until the winner finished the game.



Figure 10. Ethnic snake game board



Figure 11. The example of the instruction after the students move their pawn

Post- teaching Activities

10. Reinforced the students' understanding about describing people by asking them to mention and explain some points needed on the describing people based on the example given.
11. Closed the class.

During the teaching and learning activity, there was no significant problem. There were 24 students when this activity was conducted since the maximum students for speaking class were only 25 students. After the activity had been done, the researcher gave them a students' checklist in the end of the class. It was to know their opinion toward the medium which had used for learning English. The result is shown in the table below.

Table 3. Students' Opinion about Speaking Class

No.	Statements	Strongly Agree (%)	Agree (%)	Strongly Disagree (%)	Disagree (%)
1.	Flash multimedia that is just implemented in class is very interesting.	46	54	0	0
2.	I love the pictures and animated images presented in the multimedia.	29	63	0	8
3.	I find it much easier to understand the English topic today using the multimedia.	13	79	0	8
4.	Learning English today is very fun and interesting.	29	63	8	0
5.	I love this multimedia from the beginning to the end of its presentation/implementation.	17	75	0	8
6.	I became interested and motivated in learning English by using multimedia.	25	67	0	8
7.	I want the multimedia to be applied again in English learning because it is fun and interesting.	25	67	8	0

From the table above, 54% students agreed that this multimedia-based medium was interesting and 46% students even strongly agreed that the medium was interesting. Next, more than a half students which were 63% students as the agreed that they liked the pictures shown in the medium, 29% also strongly agreed they like the picture even though 8% strongly disagreed because of the color produced by the LCD projector affected the color of the pictures. Surprisingly, 79% of students agreed that they could understand the topic by using this medium but 8% of students strongly disagreed because they came late to the class and missed some explanation or instruction that caused some confusion. Then, 29% and 63% of students strongly agreed and agreed that today's lesson was enjoyable and fun. Luckily, 17% of students strongly agreed that they liked the medium even from the beginning until the end, and so did 75% of the students agreed about that. After that, 25% and 67% of students strongly agreed and agreed that they were more interested and motivated in learning English although 8% of students strongly disagreed with item five and six. Last, the same percentage as the previous item strongly agreed and agreed that they wanted this medium for the next meeting yet 8% of students disagreed.

Reflecting on the result of the questionnaire which more than 90% students gave positive responses in all statement related to the multimedia-based medium, the researcher implied that this product is useful and applicable for the classroom activity. Using interesting medium and consisting many attractive pictures can be some triggers since the activity in a class before was monotonous and used fewer medium. As Shyamlee and Phil (2012) said that applying multimedia in teaching English can bring some advantages such as cultivating

students' interest, promoting students' communication capacity, widening students' knowledge, improving teaching effect, improving interaction between lecturer and students, creating a context for language teaching, and providing flexibility to course content. Moreover, in this digital era, students value a technology in learning language to conventional one. It is in line with Nomass (2013) that students like using technology, like computer, in learning language. Beside students, this medium also gives significant impact to the lecturer who can deliver the material easily and in interesting way. Alsulami (2016) said that using technology in teaching English as foreign language can improve students' understanding about the material because they are used to it in their daily life.

IV. CONCLUSIONS AND SUGGESTIONS

This study was conducted due to see the use of multimedia in teaching speaking at Universitas Muhammadiyah Malang since many students thought that multimedia is important and help them during the class. As a result, using a multimedia enables lecturer to deliver the material easily and in attractive ways. Thus, it helps the students to enjoy the class, understand the material easily, and be familiar with some traditional things in Indonesia.

So, it can be concluded that this medium meet the students' need as an alternative multimedia-based medium in learning English. It also suits students' preference as a digital native in this modern era. Furthermore, it helps a lecturer in delivering the material in attractive way.

REFERENCES

- Alsulami, S. (2016). the effects of technology on learning english as a foreign language among female efl students at effatt college: An exploratory study. *Studies in Literature and Language*, (online), 12(4): 1-16, (www.cscanada.net/index.php/sll/article/download/7926/9332), retrieved on December 26, 2016.
- Ary, D. (2006). *Introduction to research in education seventh edition*. Canada: Thomson Wadsworth.
- Avedon, E. (2010). *Snakes & ladders or chutes and ladders*. (Online), (<http://www.gamesmuseum.uwaterloo.ca/VirtualExhibits/Whitehill/snakes/index.html>), retrieved on March 15, 2015.
- Brown, G., & Yule, G. (1983). *Teaching the spoken language*. Cambridge: Cambridge University Press.
- Brown, H. (2007). *Teaching by principles: An interactive approach to language pedagogy (third edition)*. New York: Pearson Education Inc.
- Hakim, S. Q. (2015). *Developing local context-based reading materials for the eighth graders of junior high school in Sanggau, West Kalimantan*. Unpublished Undergraduate's Thesis. Malang: English Department of UM.
- Harmer, J. 2007. *The Practice of english language teaching*. Cambridge: Longman.
- Meliono, I. (2011). Understanding the nusantara thought and local wisdom as an aspect of the Indonesian education. *International Journal for Historical Studies*, (online), 2 (2): 221-234, (<http://citation.itb.ac.id/pdf/JURNAL/Tawarikh/Vol.%202%20no.%202%20April%202011/7.Irma.pdf>) retrieved on October 7, 2015.

- Nomass, B. B. (2013). *The Impact of using technology in teaching english as a second language. English Language and Literature Studies*, 3(1): 111-116.
- Nunan, D. (1999). *Second language teaching & learning*. Boston: Heinle & Heinle Publishers.
- Smaldino, S. E., Lowther, D. L., & Russel J. D. (2008). *instructional technology and media for learning (ninth edition)*. New Jersey: Pearson Education Inc.
- Shyamlee, S. D. and M Phil, M. (2012). "Use of technology in english language teaching and learning": An analysis. *IPEDR* (33): 150-156, IACSIT Press, Singapore.
- Stemler, L. (1997). Educational characteristics of multimedia: A literature review. *Journal of Educational Multimedia and Hypermedia*, (Online), 6 (3-4): 339-359, (http://www.medvet.umontreal.ca/techno/eta6785/articles/multimedia_design.pdf), retrieved on January 20, 2015.
- Susanti, I. L. M. H. (2013). Developing digital storytelling based local wisdom through blended learning as an innovative media for teaching English at eighth grade students of smp negeri 1 Petang in the academic year 2012/2013. *Asia-Pacific Collaborative education Journal*, (Online), 9 (2): 95-102, (apcj.alcob.org/?module=file&act=procFileDownload&file_srl...), retrieved on January 20, 2015.
- Ur, P. (2012). *A course in English language teaching (a completely revised and updated edition of a course in language teaching)*. Cambridge: Cambridge University Press.

About the Author

Complete Name : Lulud Oktaviani
Institution : Universitas Teknokrat Indonesia
Email Address : lulud_oktaviani@teknokrat.ac.id
Education : S2 (Magister Pendidikan Bahasa Inggris)
Research Interest : Teaching Media, Multimedia, Teaching Strategy

THE EFFECT OF INSTAGRAM ON THE STUDENTS' WRITING ABILITY AT UNDERGRADUATE LEVEL

Achmad Yudi Wahyudin¹, Fatimah Mulya Sari²

Universitas Teknokrat Indonesia

achmad.yudi@teknokrat.ac.id¹

ABSTRACT

The innovations of technology in education field bring the significant change, especially to the English as a Foreign Language (EFL) teaching and learning in higher education. Instagram might be one of the alternatives tools to support the practice of teaching EFL undergraduate students. The implementation of Instagram that has achieved abundant users for the last decade might be a useful teaching media to facilitate learning process. This paper is aimed to find out whether the implementation of Instagram as a learning tool can improve EFL undergraduate students' writing skill. The subjects were two classes consisting of 80 undergraduate students who took General English at the Faculty of Engineering and Computer Sciences. The result reveals that blended learning using Instagram might be used as an effective teaching and learning tool. Thus, it could help non-english students enhance their language learning in the classroom.

Keywords: *language learning, learning tool, instagram, EFL undergraduate students, writing*

I. INTRODUCTION

The need for mastery of academic English in higher education becomes more apparent than ever before. It has been consensus that undergraduate students are required to master academic writing ability to be successful academically. Academic writing in this paper refers to various written assignments with clear purpose and point of view, logical organization, and audience engagement (Whitaker, 2009). In the university, undergraduate students ought to accomplish academic assignment in the various forms such as argument papers, expository papers, exam essay, email, blogs, and journal during the entire period of their study (Bailey, 2011). In Europe, Kruse (2013) asserts the importance of academic writing in order to enter University. Undergraduate students must have a good command of writing for not only targeting reputable job but also pursuing their master's degree. Similarly, English as a foreign language (EFL) is also taught in Indonesian university in the form of General English (GE) and English for Specific Purposes (ESP) to equip the graduates with critical thinking to understand complex issues in their respective fields of study, offer various alternative of solutions to those issues, and communicate their ideas effectively. These are crucial skills that need to be integrated in the day-to-day teaching.

The trend of EFL teaching and learning has experienced considerable change due to the emerging technology. It is believed that the teaching practice must be relevant to the condition of the learners and provide them with wider opportunities to engage with the

learning process. The learners so-called *millennials* and/or *Gen Z* have unique characteristics shaped by the exposure of internet use, digitalization, and smart device. Accordingly, blended learning that serves the combination of face-to-face and online language learning play a significant role to bridge the gap between the current condition of learners' characteristics and the emerging of technology.

The use of various applications through computers and smartphones in blended classroom has allowed the teachers to innovatively shape their strategies and approaches in language teaching and learning. Through the implementation of the current technology it appears that the undergraduate students are more involved in the teaching and learning process. Hughes (2007) studied the use of blended learning, its productiveness and the extent to which these factors affected student perceptions of the ESL writing course. Students were found to work more autonomously and to be more focused while becoming more responsible for their own learning. In fact, by applying social media such as facebook, instagram, blogs and twitter in teaching and learning process, undergraduate learners will be highly motivated to interact socially with their peers to accomplish the assigned tasks and achieve the designated learning objective.

Among social media that have been used to facilitate language learning process, Instagram has caught teachers' attention and becomes a potential media used to enhance the students' writing ability. Instagram was launched in October 2010 and rapidly gained popularity, with over 100 million daily active users as of April 2012 and over 500 million as of March 2018 (Hatch, 2018). A recent survey affirmed that Instagram is still the most popular social media network for undergraduate students at the age of 18-24 (NapoleonCat, 2017). Instagram is an online web-based and mobile photo-sharing, video-sharing, and social networking service. Therefore it enables its users to take pictures and videos, and share them either publicly or privately on the application. Further, Smith & Anderson (2018) pointed out that the infographics of social media users shows that young people around the world are eager to connect with their peers and are highly proficient at doing so through smartphone.

Apparently, several studies have been carried out to explore the use of blended learning with social media for undergraduate students. Through the process of giving posts and comments in Facebook, the undergraduate students' interest in writing is aroused and it positively affects their ability (Wahyudin, 2018). Soviyah and Etikaningsih (2018) conducted an experimental research to investigate the effectiveness of the use of Instagram application on the students' performance in writing descriptive texts. They find that the two features of Instagrams that might possibly affect the students' writing ability is photo sharing and social networks. Photo sharing feature is used as the media to write a description towards the pictures the students have uploaded. Whereas, social network features such as *loves*, *share*, and *comments*, are used to provide feedback from the peers. These features give a sense of audience to promote social interaction and facilitate learning outside of the classroom. This study is supported by the study conducted by Anggraeni (2017) and Cahyono & Wdiawati (2018). It is stated that the students' view instagram as valuable social network problem that help the to write better.

This study seeks to reveal the undergraduate students experience in applying Instagram as the tool to motivate as well as enhance their writing ability. It also investigated whether there is any significant difference of writing ability between the students who are involved in blended classroom using Instagram and those who are involved in blended classroom using Moodle platform. The discussion in this study might shed a light on the use of Instagram as the platform for language learning activity. It is hoped that educators will embrace technology and use social media networks to leverage engagement in developing students communication skills.

II. METHODS

This quantitative study involve 82 first semester students divided into experimental class and control class. The students' age in this study ranged from 20-23 years old and they did not take any English course outside of the class. The undergraduate students were the participants of GE class in which the topics covers, *greeting and introduction, talking about numbers, how to make telephone conversation, describing company, and describing public places during travel*. The experiment lasted for a semester started with pre-test in the beginning of the meeting and ended with a post-test in the last meeting. Those tests were concerned with describing public places consisted of identification and description (Gerot & Wignell, 1994) since this genre is suitable for undergraduate students who are still in the first year.

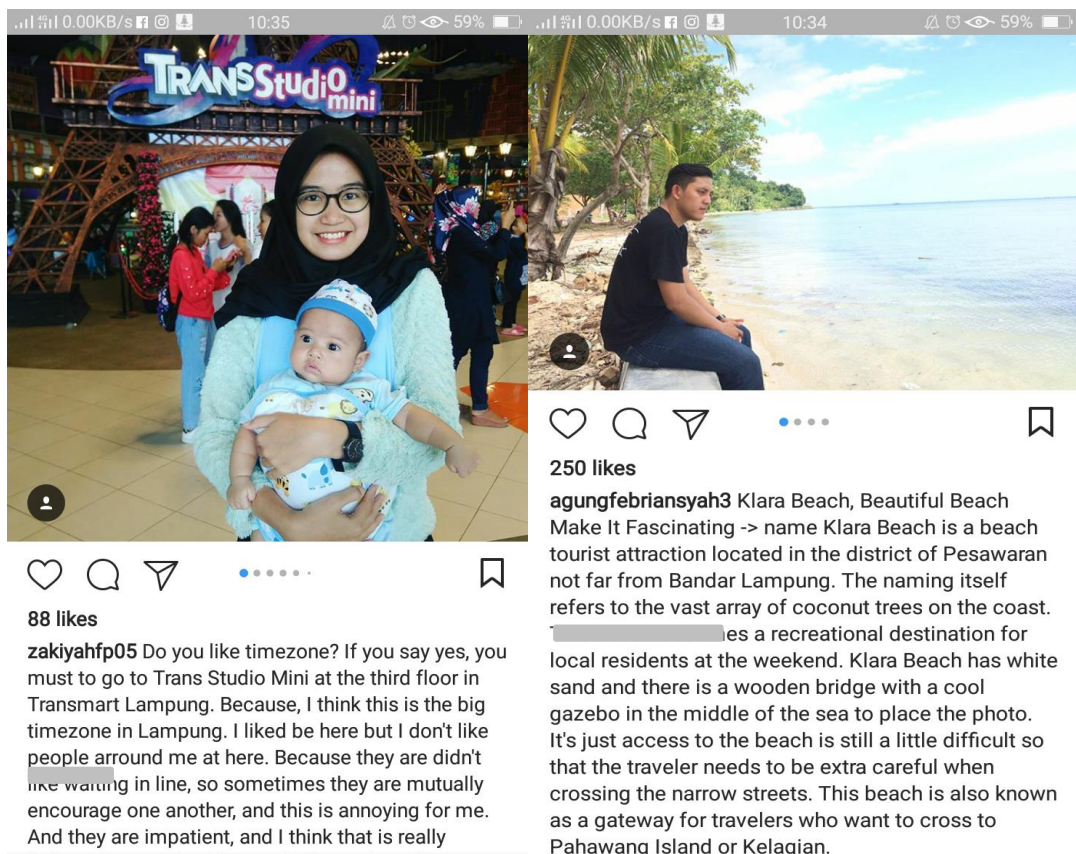

Figure 1.1 The sample of students' attempt to post their writing

During the treatment, the teacher combined the process writing in which the teacher applied planning, drafting, revising and editing stages (Kroll, 2001) and online learning with Instagram as the medium to facilitate the students' peer feedback towards the descriptive essay they have composed. The students' work was analysed by the scoring criteria adapted from Hughes (2003). The criteria ranged from 0 to 100 where content, organization, language use, vocabulary, and mechanics became the aspects being measured. The students' work is graded by multiple rater to ensure the inter-rater reliability of the test. Several statistical analyses such as normality test, homogeneity test were done through SPSS (ver.15). In addition, the following hypotheses were also tested by utilizing *independent t-test* using similar software.

H_0 = There is no significant difference of writing ability between experimental group and controls group

H_1 = There is a significant difference of writing ability between experimental group and control group.

In order to gain the students' perspective towards the use of Instagram, a close-neded questionnaire consisting of 10 items is used in the present study. The questionnaire covers Information associated with the knowledge of blended learning, usefulness, and satisfaction in using Instagram as a tool for learning. The data collected from the questionnaire were analysed based on those who agree and disagree with the statements.

III. RESULTS AND DISCUSSION

The present study aims at confirming whether the use of Instagram in blended writing classroom impact positively on the EFL students' writing ability. The subjects in experimental and control group were assigned to write an descriptive essay in the pre-test and post test. The test lasted in 100 minutes where the students were not allowed to consult any dictionary and internet source. The impact of Instagram can be seen in the difference of writing ability between the experimental and control group.

Table 3.1 The comparison between experimental and control group in pre-test.

Group	Mean	Minimum	Maximum	SD
Experimental	78,46	43	86	10.06
Control	77.21	58	81	5.82

Table 3.1 suggested that the students who got treatment in the experimental group and the students treated in the control group have proportionally equal ability. It can be seen that the mean score of experimental group is 78.47 while the mean of control group is 77.21. After studying for almost a semester, the post test was administered to both groups and the result can be seen in the following table.

Table 3.2 The comparison between experimental and control group in post test

Group	Mean	Minimum	Maximum	SD
Experimental	83.56	66	92	4.31
Control	80.92	67	88	3.47

Table 3.2 pointed out that the students who studied in the experimental class performed better than the students who studied in the control group. It is obvious that the mean score of experimental group is 92 while the mean of control group is 88. Furthermore, the formulated hypotheses were tested to investigate whether there is any significant difference of writing ability between experimental and control group. The result of hypothesis testing can be seen in the following table.

Table 3.3 The computation of independent t-test

		Mean difference	t	df	Sig. (2-tailed)
Writing Ability	equal variance assumed	2.63	3.03	79	.003
	equal variance not assumed	2.63	3.01	78	.004

Table 3.3 shows that the experimental and control group are different significantly at .003 ($t = 3.03$) in which it is below α (.05). Also, it is noted that the mean difference between the two groups is 2.63 with the degree of freedom 79. Based on this result, the null (H_0) hypothesis was rejected and in other words, there is a significant difference of writing ability between the experimental and control group.

In addition, at the end of the semester, the students treated in the experimental group were also required to fill out the questionnaire. The data obtained through questionnaires is analysed and categorized into the students' belief towards instagram and the students' perception towards Instagram. The results of both categories can be seen in the following table.

Table 3.4 The Students' Belief towards Instagram

No	Statement	Number of Respondents			N
		Agree	Disagree	Don't know	
1	Instagram is an application that uses internet conn	41	0	0	41
2	Instagram eases the circulation of information	34	4	3	41
3	Instagram can be accessed	26	10	5	41

	anywhere at anytime				
4	Instagram is used to gain more knowledge	25	13	3	41

Table 3.4 suggested that all students (41) have agreed that Instagram is an application that uses internet connection and can be accessed anywhere and anytime. Majority of the students belief that Instagram eases the circulation of information and gain more knowledge.

Table 3.5 The Students' Perception towards Instagram

No	Statement	Number of Respondents			N
		Agree	Disagree	Don't know	
1	Instagram helps students to access the task	10	26	5	41
2	Instagram is an application that ease the learning process	28	3	10	41
3	Instagram is an application that facilitate discussion	22	11	8	41
4	Instagram features can be used to assisst the writing process	26	9	6	41

Table 3.5 pointed out that majority of Instagram is an application that eases the learning process, facilitate discussion and assists the writing process. Meanwhile, Majority of the students belief that Instagram did not help him in accessing the task. It can be seen that most of them (26) disagreed with that statements.

The finding indicates that the use of Instagram in blended learning classroom give more positive impact to the students' writing ability than any teaching method used in control group. The finding of the present study might support the several studies conducted by Anggraeni (2017), Cahyono & Widiawati (2018) and Soviyah & Etikaningsih (2018). Instagram has caught the students' attention when the lecturer introduced it in the classroom. By using Instagram, a learning space was given to provide an opportunity for students to practice their writing skill, as well as improve their analytical and error correction skill. An online posting on Instagram provided an opportunity for students to collaboratively revise their writing in a non-classroom context (Razak and Saeed, 2014).

The improvement of writing score is noticed when the students in experimental group have done their writing. The classroom practice also feature a process writing that involves pre writing, drafting, editing, revising, and publising. Through this process, the students were guided by the lecturer to post their draft on Instagram. Afterwards, the students will have individual writing drafts reviewed by peers. They were asked to provide comments for at least three pieces of work from the peers uploaded in the Instagram. To enhance the students' awareness of the macro aspects of descriptive genre such as content and organization, a training practice and explicit instructions for the number of responses in these two areas were given during the treatment (See Choi,

2014). Once the students received comments and feedbacks from their peers, they were required to revise and edit their work. The reason why the increase of writing ability happened significantly in experimental group might be due to the fact that Instagram trigger the students' motivation and build their self-esteem in learning. In addition Instagram also build a sense of audience for a student to build confidence to be aware of the existence of readers. Instagram also provided constructive and useful comments as well as likes that can motivate the students to write the descriptive writing better. The feedback processes given by the lecturer and peers had made the students more aware about their errors or mistakes in writing. On the other hand, several students were able to make comments related to the ideas and organization of the descriptive paper. Even though the increase occurs in the experimental group, the other factors such as the lecturer's instruction and guidance in the classroom might play a significant role in improving the students' writing ability. The students were assisted by the lecturer's expertise and judgement in various ways to solve the assignment and difficulties that the students encountered during the lesson (See Guasch et al, 2013).

The results from the questionnaire also support the finding where the students has positive perception towards the use of instagram. The blended learning model involves the use of Instagram by the lecturer to make some posts consisting of steps of describing a place so that students can learn independently in a structured manner. With the blended learning model, the students were notified to plan their writing and access the learning material before entering the class. They also can figure out the description of activities designated by the lecturers so that they can learn the material independently through Instagram and the teachers will be able to explore learning process.

The results of a similar study stated that the students are eager to participate in learning process when the discussion is facilitated. In Instagram the students discussed the sample of descriptive text given by the lecturer. The students are exposed by the linguistic feature and schematic structures so that they can understand how to write a descriptive text. The feature of *comment* on Instagram facilitate question and answer session so that the lecturer can give more guidance to the students. Giving comment,question,or suggestion can arouse high-level thinking skills. The results of several studies show three aspects of user friendliness, interactivity, and practicality become the main reasons of learning by using Instagram. Learning is easier when the students feel the media they use can be easily accessed and facilitate the interaction. The study attempts to confirm that the use of Instagram gives positive impact on the students' writing ability.

Some limitations were found in the present study in which the increase of each aspects of writing was not taken much attention. Further investigation towards the impact of online peer feedback on the writing aspects such content, organization, vocabulary, language use, and mechanics might be very important to find out to what extent the use of Instagram in might bring positive impact on the students' mastery of writing at undergraduate level.

IV. CONCLUSIONS AND SUGGESTIONS

The study attempts to confirm whether Instagram positively brings positive effect to the undergraduate students' writing ability. The findings reveals that the students' writing

ability increase in terms of means and the students treated in blended learning class with Instagram use perform better than their counterpart. The present study might shed a light to the research on social media use in language classroom. The use of social media in language teaching in higher education has importantly played a significant role in triggering the students' interest and confidence in writing. Instagram might be one of the alternative media to support the practice of teaching writing outside of the classroom. The utility of Instagram is very effective to facilitate non-classroom learning to solve time constraints often encountered by some English teachers in Indonesia.

Due to the limitation in this study, further studies might use larger sample to confirm the transferability of the effect of Instagram on the undergraduate students' writing ability. Exploring more the effect of Instagram on the aspects of writing may bring significant pedagogical implication. It is also suggested that the types of feedback in comments section is explored for the future study.

Acknowledgement and Funding

The writers express a great gratitude to Ministry of Research, Technology and Higher Education of Republic of Indonesia for their support in funding this research. This article is one of the outcomes of the research grant at the year of 2017-2018. The writers also thank Universitas Teknokrat Indonesia for its support in providing all necessary resources to accomplish the research participated by the students who studied in Academic Year of 2017/2018.

REFERENCES

- Anggraeni, C. W. (2017). Students' perspectives toward the use of instagram in writing class. Paper presented at The 1st English Language and Literature International Conference (ELLIC) 2017 at Universitas Muhammadiyah Semarang.
- Bailey, S. (2011). *Academic writing*. (3rd edition). New York: Routledge. Retrieved from: [https://www.kau.edu.sa/files/0013287/subjects/academic-writing-handbook-international-students-3rd-ed%20\(2\).pdf](https://www.kau.edu.sa/files/0013287/subjects/academic-writing-handbook-international-students-3rd-ed%20(2).pdf)
- Choi, J. 2014. Online peer discourse in a writing classroom. *International Journal of Teaching and Learning in Higher Education*, Vol. 26 (2). pp.217-231.
- Gerot, P. and Wignell, L. (1994). *Making sense of functional grammar*. Queensland: Gerd Stabler.
- Guasch, T., Espasa, A., Alvarez, I.M., & Kirschner, P. A. (2013). Effects of feedback on collaborative writing in an online learning environment, *Distance Education*, 34 (3), pp. 324 - 338, DOI: 10.1080/01587919.2013.835772
- Hatch, C. (2018). *Be in the know: 2018 social media statistics you should know*. Retrieved from: <https://www.disruptiveadvertising.com/social-media/be-in-the-know-2018-social-media-statistics-you-should-know/>
- Hughes, A. (2003). *Testing for language teachers (2nd edition)*. Cambridge: Cambridge University Press.
- Hughes, G. (2007). Using blended learning to increase learner support and improve retention. *Teaching in Higher Education*, 12(3). pp.349-363.
- Kroll, B. (2001). Considerations for teaching an ESL/EFL writing course. In M. Celce-Murcia (Ed.), *Teaching English as a second or foreign language* (3rd ed., pp. 219-232). Boston, MA: Heinle & Heinle.

- Kruse, O. (2013). Perspectives on academic writing in european higher education: genres, practices, and competences. *Revista de Docencia Universitaria*, 11(1), pp.37-58.
- NapoleonCat. (2017). Instagram user demographics in Indonesia – March 2017. Retrieved from: <https://napoleoncat.com/blog/en/instagram-user-demographics-in-indonesia-march-2017/>
- Razak, N. A. and Saeed, M. A. (2014). Collaborative writing revision process among learners of English as a foreign language (EFL) in an online community of practice (CoP). *Australasian Journal of Educational Technology*, 30(5), pp.580-599.
- Smith, A. and Anderson, M. (2018). Social media use in 2018. Retrieved from: <http://www.pewinternet.org/2018/03/01/social-media-use-in-2018/>
- Soviyah and Etikaningsih, D. R.. (2018). Instagram use to enhance ability in writing descriptive texts. *Indonesian EFL Journal*, 4(2). pp.32-38
- Wahyudin, A.Y. (2018). The impact of online peer feedback on the students' writing ability at tertiary level. *Bahtera*, 17 (1). pp 1-10.
- Whitaker, A. (2009). *Academic writing guide: A step-by-step guide to writing academic papers*. Bratislava, Slovakia: City University of Seattle. Retrieved from: <http://www.vsm.sk/Curriculum/academicupport/academicwritingguide.pdf>

About the Authors

Author 1

Complete Name : Achmad Yudi Wahyudin, M.Pd.
Institution : Universitas Teknokrat Indonesia
Email Address : achmad.yudi@teknokrat.ac.id
Education : Master's degree in English Education, UPI
Research Interest : Curriculum & Material Development, English for Specific Purposes, Educational Technology

Author 2

Complete Name : Fatimah Mulya Sari, M.Pd.
Institution : Universitas Teknokrat Indonesia
Email Address : fatimah@teknokrat.ac.id
Education : Master's degree in English Education, UNS
Research Interest : English for Specific Purposes and Educational Technology

THE EFFECT OF BLENDED LEARNING ACTIVITY IN IMPROVING THE STUDENTS' ENGLISH SPEAKING SKILL IN THE CONTEXT OF ENGLISH AS A FOREIGN LANGUAGE

Rachma Vivien Belinda¹, Patuan Raja², Ari Nurweni³

English Department, University of Lampung^{1,2,3}

rachmabelinda@gmail.com¹

ABSTRACT

This study is an attempt to elucidate the problem of many Indonesian students who get failure in speaking English fluently and accurately. On behalf of that reason, this research is done to investigate the patterns of the students' discourse in blended learning activity of the advanced EFL (English as a Foreign Language) learners. The analysis of the students' discourse showed that the online classroom activity gives more benefits for the students in performing their English speaking skills. Furthermore, the students predominantly tend to avoid speaking because they get nervous of which it leads some of them to produce code-mixing in their verbal performances. Thus, it suggests that blended learning activity gives the students a greater chance to improve their speaking skills so that the frequency of code-mixing can be diminished.

Keywords: *speaking, blended learning, online classroom, code-mixing*

I. INTRODUCTION

Meaningful context and natural environment are two of the most important things for people acquiring a language. Those make them able to produce utterances in the target language meaningfully because they have a chance to practice a real life interaction. It comes from a theory saying that language can be better acquired if it happens by nature and meaningful. Furthermore, maximum exposure and an authentic linguistic form of the language are also needed (Sivertzen, 2013). Like an infant, it acquires its first language by observing it of which it listens more compared to speak. The infants tend to listen to its surrounding; what their parents or family said. After that, they try to imitate the sounds. On the other words, they get more input that can be internalized and stored inside their head. In a case of English language learners whose first language is not English, this process can also happen. Even though language learners need to comprehend the knowledge of the language, at the end they are actually going to use it and produce some utterances in particular situation.

For advanced English learners in Indonesia, they already got the prior knowledge of English language; however, it is still difficult for them to use the language in communication practice since they are English as Foreign Language (EFL) learners. Mostly, they get no chance to

practice their English outside school. It happens because they have no environment in which it supports them to talk in English except their English classroom. Furthermore, the Indonesian students predominantly learn English at school only for solving grammar problem. They usually memorize the vocabulary and the set of grammar of English (Ivone, 2015) instead of using it for the communication practice. This factor makes the students unwilling to speak because they only focus on solving grammar problems to pass their grade.

In order to help the students to practice their speaking skill, it is needed to provide them a chance to use their English not only inside the classroom but also outside the classroom. One of the most possible ways to make this happen is by providing an additional class for the students; however, the problem is some of the students do not have much time to have an additional class. Moreover, financial problem is one of the crucial problems in this case. Having additional class after school appears not to be effective.

The problem above can actually be solved by using 21st century technology. The use of technology in this modern era cannot be evaded. Almost all people nowadays always hold their smartphone everytime and everywhere. They use it as if it is a part of their body. This also happens to many learners in the world. They always bring that wireless device wherever they go; even to school. Interestingly, there are still some people in our society who think that it is a bad thing for students having a personal gadget because of many reasons one of which it is avoiding them from studying and learning. However, smartphone actually can be the ultimate devices which can make the students improve their skill. So, instead of worrying about the students and their gadget and trying to make them stay away from it, why do not we try to utilize it as one of the perfect media to make them learn?

In this research, blended learning activity occurred. The offline class was conducted for one and a half months in an advance speaking class of the university level in Indonesia. Additionally, the online class was also conducted utilizing the use of WhatsApp chatting application by doing a group chat discussion in accordance with the topic discussed inside the classroom. This was done in order to find out the students' discourse pattern, so that the teacher can help them improve their English speaking skill.

One of the most common speech act produced by the EFL students is code-mixing or code switching. Domalewska (2015) states code-switching as the common classroom practice in his research. All of the bilingual students in his class produced code-switching. The students tend to produce it as one of their communication strategies to make the chat run smoother. This also happened when this research was conducted. The students produced code-mixing in blended learning activity. They produced utterances in Bahasa Indonesia in the middle of English conversation. It happened in some random situation. However, the frequency of code-mixing in online class tends to be smaller than offline class. Below is the chart of frequency stating the difference between code-mixing in both online and offline class.

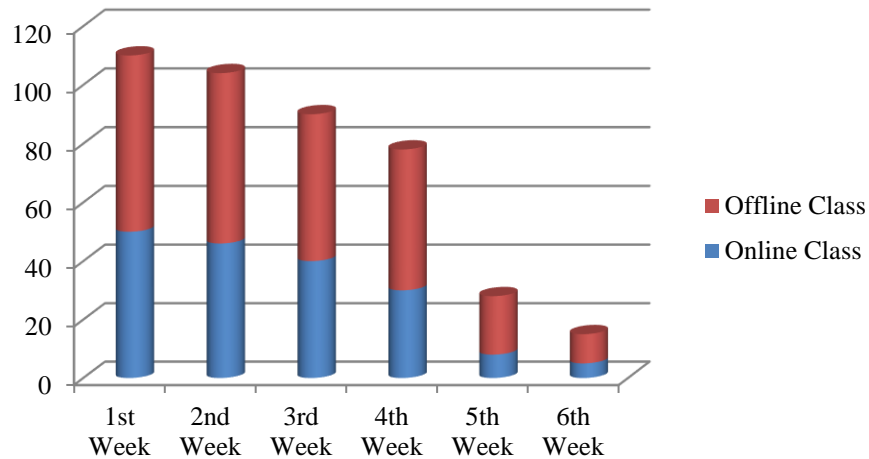

Chart 1 The difference between code-mixing in both online and offline class.

According to the chart above, the code-mixing produced in the offline class by the students has a greater frequency compared to the online class. For the first two weeks, the frequency of code-mixing is slightly different in offline class; however, it is decreasing in online class. This happened because at the first two weeks in which they discussed about the benefits of something, they tend to be clumsy and unwilling to speak. It is because this topic was decided by the teacher. It also happened in the 3rd and 4th weeks. In these weeks, the students discussed about their favorite movie; however, the teacher limits the movie into English movie only. It made most of the female students unwilling to discuss because they prefer Korean and Indian movie. Interestingly, the code-mixing utterances have decreased in the 5th and 6th weeks. In these weeks, the teacher let the students to discuss any topic they wanted to discuss. Here are the transcripts of some utterances produced by the students.

1st week

*we can promote our- our- product by using smartphone, and we, we **apa ya**, we can promote the product in our **medsos**. So, we- we- we-we not **apa ya**, we should not, we should not go **apa**, we should not have **toko** or something like that.*

From the transcript above, it can be seen that the students produced many non English words like ‘*apa ya*’ which means ‘what is that?’ and ‘*medsos*’ which is the abbreviation from ‘*media sosial*’ which mean social media. There is also the word ‘*toko*’ which means ‘shop’. Those words are Indonesian words.

2nd week

*I would love to join the discuss- the discussion, but when I try to talk with English I feel so **ndredeg**.*

In the second week, some of the students still produced many code-mixing one of the example is the transcript above. The bold word '*ndredeg*' above means 'nervous'. It is actually not an Indonesian word. It seems like Javanese word in a slang way of describing that our heart is beating so fast. A typical situation when we feel nervous.

3rd week

*..for me, because I like action movie and I had watched eh—**apasih**, part **sebelumnya gitu**.*

In the third week, the students began to discuss about the movie they like. In that session, some of the students still produced many code-switching. The bold words above are Indonesian words. The word '*apasih*' means 'what is that?'; it is a typical way when we try to remember or think of what we want to say. Furthermore, the words '*sebelumnya*' means 'previous'. The students tried to say 'the previous part'. Finally, the word '*gitu*' means 'something like that'. Below is the transcript from one of the utterances in the fourth week.

4th week

*I think you should watch the marvel movie because it was great film. I think it was a great film because the action like real and looks like **gak norak** in Indonesia.*

In the fourth week, they still discussed about movie. The bold words above mean 'not tacky'. The word '*gak*' means 'not' and '*norak*' means 'tacky'. Here are the examples from the fifth and the sixth weeks.

5th week

*I suggest to them to buy and also to taste the **rujak bebeg**.*

6th week

*Agree **kak**, we have to be brave right?*

The typical code-mixing occurred in week five and six is the code-mixing which is actually necessary to utter. For example, in the fifth week the students uttered the words '*rujak bebeg*' which actually cannot be translated to English. We can only explain it in English. So, *rujak bebeg* is a traditional snack in Indonesia consists of various sour fruits which are being smashed by wooden tool and added by various spices from Indonesia making the taste so spicy. Moreover, the word '*kak*' in the sixth week is a kind of nickname for someone older, for example older sisters, older brothers, and seniors at school or university. It is really common to call those people with *kakak* or *kak*. It is also sometimes added by their name afterward, for example *kak Budi*. It is the sociolinguistics of Indonesian people. If we call

someone older with only their name, it can be considered impolite. The utterance *kak* above refers to the teacher who is actually the students' senior in their university.

Furthermore, we can draw a conclusion after analyzing the chart above. Surprisingly, the code-mixing utterances were decreasing from the first week to the sixth week. This happened because the students intensively join the group chat discussion out of their normal offline class making them able to tackle their own problem in producing unnecessary code-mixing utterances. They seemed used to it, and it made them able to speak more fluently at last. This is in line with the research conducted by Abu-Sheera (2015) who found out that the students' level in speaking skill was highly improving effectively by blended learning. Moreover, the topics used in the discussion also influence their utterances. The students get more positive aspect that can help them get a natural environment to speak up by having a topic that is freely chosen by them (Belinda, 2018). This happened because a good situation for language learner to speak is the situation in which the students can have a natural environment where they can speak naturally and not being forced by any party including the teacher. Belinda (2018) states "Making the students pop something the teacher wish to say out is not good for their language practice. On the other hand, letting them say what they want to say is better so that they do not feel pressured or forced to do it where can lead them to avoid speaking".

II. CONCLUSION AND SUGGESTIONS

Conclusion

In short, we can say that the students predominantly tend to avoid speaking because they get nervous of which it leads some of them to produce code-mixing in their verbal performances. This is also highlighted by the students' statement saying that they feel nervous when they have to speak in English. Interestingly, after joining blended learning activity, the students have a greater chance to improve their speaking skills so that the frequency of code-mixing can be diminished.

Suggestions

Conducting this research, the author originated some points which should be deliberated for the broaden research, (1) the time of the treatment should be longer than one and a half month, so that more valid data can be obtained, and (2) the subject should be better chosen randomly, so that it can denote the rest of the population.

REFERENCES

- Abu-Sheera, N. M. (2015). The effect of using blended learning on enhancing eleventh graders' speaking skills in Khanyounis Schools. Gaza: Al-Azhar University-Gaza.
- Belinda, Rachma. (2018). The use of chatting in blended learning class in improving the students' English speaking skill in the context of English as a foreign language. *UNILA Journal of English teaching (U-JET)*, 7(3).

Domalewska, Dorota. (2015). Classroom discourse Analysis in EFL Elementary Lessons. *International Journal of Languages, Literature and Linguistics*, 1(1), 6-8.

Ivone, F. (2005). Teaching English as a foreign language in Indonesia: The urge to improve classroom vocabulary instruction. *TEFLIN Journal*, 16(2), 195-208.

Sivertzen. (2013). The role of input in early second language acquisition: A study of the long-term effects of initial extra English input on Norwegian 4th graders' receptive vocabulary. Master thesis in English NTNU.



1st ICON - ELTL
International Conference on
English Language Teaching and Learning

ISBN 978-602-0860-30-5



**INSTITUTE FOR RESEARCH AND COMMUNITY SERVICE
UNIVERSITY OF LAMPUNG**