

PAPER • OPEN ACCESS

Technical and technology aspect assessment of biogas agroindustry from cow manure: case study on cattle livestock industry in South Lampung District

To cite this article: S Hidayati *et al* 2019 *IOP Conf. Ser.: Earth Environ. Sci.* **230** 012072

View the [article online](#) for updates and enhancements.

<https://iopscience.iop.org/article/10.1088/1755-1315/230/1/012072/pdf>



IOP | ebooks™

Bringing you innovative digital publishing with leading voices to create your essential collection of books in STEM research.

Start exploring the collection - download the first chapter of every title for free.

Technical and technology aspect assessment of biogas agroindustry from cow manure: case study on cattle livestock industry in South Lampung District

S Hidayati, T P Utomo, E Suroso and Z A Maktub

Departement of Agriculture Product Technology, Lampung University, Lampung, Indonesia

E-mail: srihidayati.unila@gmail.com

Abstract. Farm waste is one of the potential causes for environmental pollution if it is not handled properly. One effort is to utilize livestock waste in the form of animal waste, as raw material, for the biogas industry. The purpose of this study was to determine the appropriate type of biogas reactor and feasibility of cow manure agroindustrial biogas development in acattle fattening industries in South Lampung Regency in terms of technical and technological aspect. The results showed that based on the exponential comparison method the appropriate type of biogas reactor was Modified Lagoon Anaerobic Reactor Cover (CoLAR) with an MPE value of 5,701.-The Modified CoLAR biogas reactor with capacity of 198,000 kg.day⁻¹ cow manure would produce 1,663.2 m³.day⁻¹ of biogas that equivalent to 1,093 m³.day⁻¹ of methane. Based on these results, it was known that the potential of electrical energy produced by the installation of biogas was 5,136 kWh and 214 kW of electricity power.

1. Introduction

One of the problems that occur in the cattle breeding industry is the presence of waste in the form of animal waste, urine and food waste. Those wastes cause environmental pollution and especially in relation to human and environmental health. In general, cattle breeding companies utilize animal waste for fertiliser and give it to communities who need it. One farm in South Lampung Regency produced cow manure around 198,000 kg or 198 tons per day. But, its utilization is not optimal and becomes problem especially during rainy season, where off-odour occurs. Meanwhile, cattle farming and the communities around the farm still rely on the state-owned company for fulfilling electricity and other energy needs.

Energy poverty is exhibited by a lack of access to electricity, which is essential element to meeting basic human needs. Based on this condition, an effort is needed to utilize cow manure into fuels such as biogas. Biogas technology with the concept of zero waste is expected to reduce the rate of global warming and eco-friendly renewable energy [1]. In addition to being an alternative energy, biogas can also reduce environmental problems, such as air pollution, soil pollution, and global warming, and its easy operation and a wide selection of organic wastes feedstock [2], with its dual benefits as a waste management tool and simultaneous energy production. Biogas technology is the biochemical conversion technology of bio-energy conversion where decomposition or degradation of organic



matter occurred in the absence of oxygen by microorganisms. For example, small-scale biogas plants are widely and increasingly used to transform waste into useful gas [3] and may represent an economically plausible technology, which is producing biogas as a main product and simultaneously producing digestate (as fertilizer) as a by-product through waste degradation [4]. The effectiveness of cow manure for biogas production with averaged cumulative biogas yield and methane content observed was 0.15 L.kg^{-1} VS added and 47%, respectively [5]. Biogas from cow manure with 1 kg produced as much as 40 liters of biogas, while chicken dung with the same amount produced 70 liters. Biogas has a high energy content which is not less than the energy content of the fuel fossil [6]. The calorific value of 1 m^3 biogas is equivalent to 0.6 - 0.8 liters of kerosene. For producing 1 Kwh of electricity, it takes 0.62-1 cubic meters of biogas which is equivalent to 0.52 liters diesel oil. Therefore biogas is very suitable to replace kerosene, LPG and ingredients other fossil fuels liters [6]. It is always difficult to adopt new digester technology within households. Recommendations for various models implemented within the country are needed. The design of the biogas plants varies based on geographical locations, availability of feedstock and climatic conditions [7]. In general for Asia, the fixed dome model is the most commonly used exception Indonesia who use cow manure as their raw material [8]. The purpose of this study was to determine the technical feasibility of industrial biogas processing from cow manure in the cattle livestock industry in southern Lampung District.

2. Research Methods

The research method used was survey method, observation, literature study and interviews with experts (academicians) related to the problem of developing biogas agro-cow manure waste and the company in South Lampung Regency. This research were divided into two stages, namely (1) determining the appropriate type of biogas reactor by distributing questionnaires to 3 (three) experts from academia using the Exponential Comparison Method (ECM) with alternative types of biogas reactor installation were complete-mix, plug-flow and modified cover lagoon anaerobic reactor (CoLar) and (2) feasibility analysis of the establishment of a cow manure biogas installation based on technical and technological aspects.

3. Results and Discussion

3.1. Determination of the appropriate type of appropriate biogas reactor

The appropriate type of biogas reactor in this study was using anaerobic work system. Some decision criteria used as determinants of appropriate types of biogas reactor installations was listed in Table 1.

Table 1. Criteria for determine the type of biogas reactor.

Criteria	Value t
Investment capital needs	5
Operational costs needs	5
Land area requirements	2
Expert ability needs	3
Production capacity	4
Results efficiency	4
Environmental impacts	4
Sustainability of biogas reactor	5

The most decisive criteria in the selection of biogas reactor installations in this study was investment capital needs and operational costs needs and sustainability of biogas reactor with 5 of weight point. These three criteria were important because the company was currently concentrating on its main production activities, namely cattle fattening.

The next criterion that were important in determining the appropriate type biogas reactor installation selection decisions were the production capacity, the result efficiency, and its

environmental impact with 4 of weighting point. Reactor capacity was very important due to large amount of cow manure produced at the company, around 198,000 kg or 198 tons. The criteria for the efficiency of biogas yields was important because the biogas results from the selection of the type of biogas reactor installation used must have high yield efficiency considering the large amount of cow manure. Environmental impact was important because the biogas reactor must be environmentally friendly or at least have a minimum negative impact on the environment, so as not to cause anxiety or disrupt the daily activities of the community. Relations with the environment and surrounding communities that have been established must be maintained with the establishment of a biogas reactor installation.

Several considerations in choosing the appropriate type of biogas reactors were to be considered, including: (1) easy installation, (2) easy to move if not used (depending on scale), (3) easily renovated if leaked, (4) practical and not easy maintenance clogged, (5) airtight, (6) resistant to weather and earthquakes and (7) has a long service life. In this study, 3 types of biogas reactor installations were chosen as alternative choices. Hamilton states that basically all anaerobic digester has the same function that is to hold dirt in the absence of oxygen and maintain the right conditions for methane formation. That there were at least 7 (seven) anaerobic digesters (reactors) commonly used namely covered lagoon, complete mix digester, plug flow digester, solids recycling, fixed film digester and suspended media digesters (UASB) and Sequencing Batch Digester (ASBR) [9]. The result of determination of the appropriate type of biogas reactor based on the Exponential Comparison Method (ECM) is shown in Table 2.

Table 2. The resolute of the appropriate type of biogas reactor using ECM.

Expert	Complete Mix Biogas Reactor	Plug Flow Biogas Reactor	Modified CoLAR Biogas Reactor
1	1.987	7.728	5.656
2	937	1.405	8.670
3	859	859	2.777
Average	1.261	3.331	5.701

The Modified CoLAR Biogas Reactor was the highest with 5.701 of MPE value. The Modified CoLAR was a simple design biogas reactor. This biogas reactor was equipped with a cover that serves as a catcher of gas produced during the decomposition process. The gas produced would be trapped under the lid, and then it would be channelled through the pipe. In terms of cost, this digester was the cheapest digester. But the drawback, this digester requires a large pool and temperature warm so it was not suitable for cold regions. But when in the summer and the pool is heated, production was 35% higher than in winter. Isdiyanto and Hasanudin [10] in their research tried to develop the application of CoLAR system bioreactors in the tapioca flour industry. The CoLAR system was able to produce an average biogas production of 485.4 m³ / day with methane content of around 58.8% [2]. Laginestra and Allan stated that covered lagoons have a positive impact on the environment, some of which can control odours, capture greenhouse gases and minimize carbon footprint.

The design of biogas reactor using Modified CoLAR in was a lagoon covered with a HDPE (High Density Poly Ethane) cover with varying thickness which functions to capture biogas. The CoLAR design can be seen in Figure 1.

CoLAR modification designed in this study was the presence of additional stirrers in the lagoon. The stirring system that was designed in this study was using a paralon pipe with a length of adjusting the lagoon length and then given several holes at the end which aimed to drain back the liquid waste into the lagoon, which had been sucked by the other pipe. This piping system adopts a gas mixing system where at the end of the lance is given several holes for circulation. There is no mixing of gas in

the stirring designed in the modified CoLAR This system adopts a working system on pumped (jet) mixing that does not mix liquid waste with gas (Figure 2)

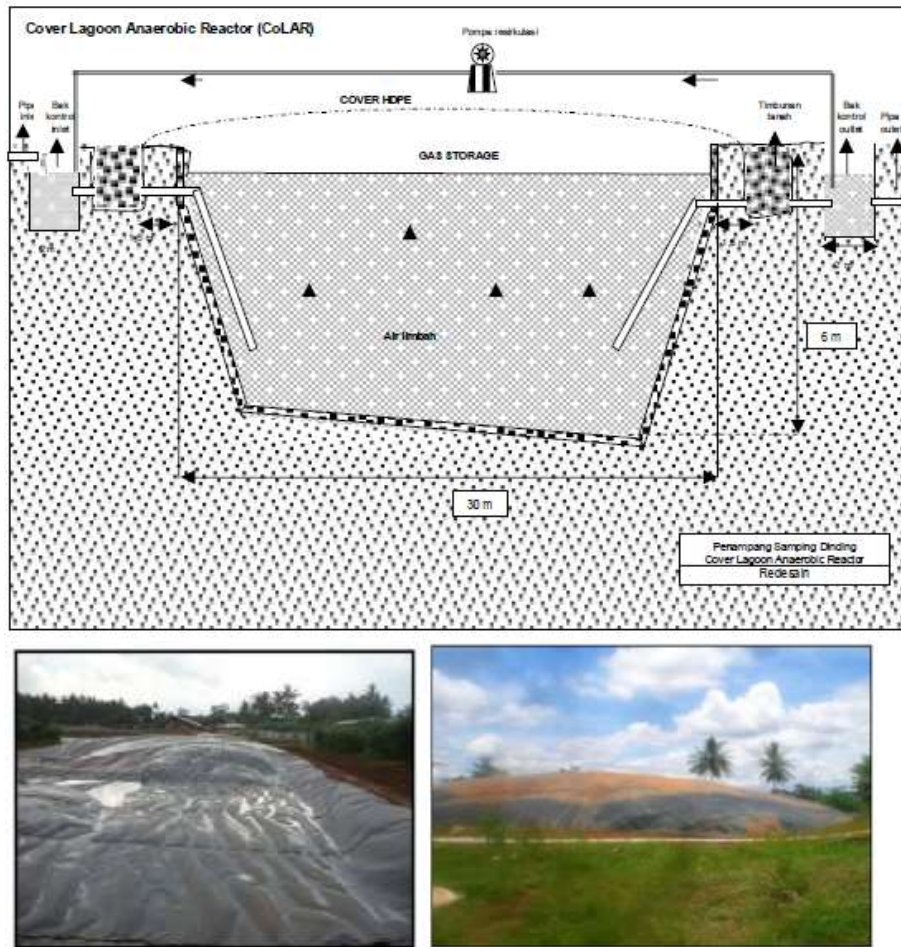

Figure 1.CoLAR design [21].

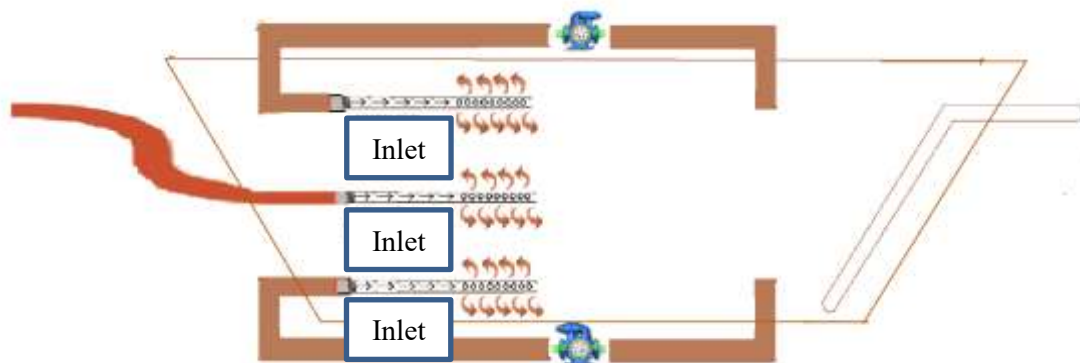

Figure 2.Draft system design in Modified CoLAR.

3.2. Feasibility of cow manure agroindustrial biogas development in term of technical and technological aspects

The feasibility of cow manure agroindustrial biogas development in a fattening cow company was carried out using the potential hypothesis for biogas reactors. Widodo and Hendriadi [11] have carried out the engineering and development of biogas reactors located at DarulFallah, Ciampea, Bogor Agricultural Boarding School in the 2005. In the engineering and development of the biogas reactor a fixed dome type biogas reactor was designed for 10 cows (with 20 kg cow manure) (Table 3) [11].

Table 3. Performance of samples of biogas installations.

Description	Reference	Test and analysis result
1. Material Conditions (Cow Manure)		
Total Solid, kg/cow/day	4.8	4.2
Volatile Solid, kg/cow/day	3.9	3.8
Moisture content, %	7-9	13.59
C/N rasio	1:25 1:30	1:17
COD, mg/l		19800
BOD / COD		0.06
2. Conditions in the reactor (process)		
Temperature, °C	35	25 - 27
pH	7.0 – 8.0	7 – 8.6
3. Biogas Chemical Content		
CH ₄ , %	50 - 60	77.13
CO ₂ , %	30 - 40	20.88
H ₂ S, µg/m ³	< 1%	1544.46
NH ₃ , µg/m ³		40.12
4. Mud Output Condition from the reactor (effluent)		
COD	500 - 2500	1960
BOD / COD	0.5	0.37
Nutrient content (main),%		
Nitrogen	1.45	1.82
Posfor	1.1	0.73
Pottasium	1.1	0.41
5. Performance		
lighting, m ³ /hour	0.11 – 0.15	0.15 – 0.3
	(Lighting is equivalent to 60 watts light bulb = 100 candle power = 620 lumens). Pressure: 70-85 mmH ₂ O	Pressure = 30 - 60 mmH ₂ O
Gas stove, m ³ /hour	0.2 – 0.45	0.2 – 0.4
	0.3 m ³ /man /day Pressure: 75 - 90 mmH ₂ O	pressure = 60 - 85 mmH ₂ O

Source: Widodo and Hendriadi [11]

Potential Raw Materials for Biogas at this company based on the number of cows in cattle companies per day ranges from 8,500 - 9,500 cow per day. Biogas capacity estimates produced could be estimated using following calculation.

1. Production of cow manure per day = 198,000 kg
2. Percentage of Total Solid (TS) and Volatile Solid (VS)
 - % TS = 21% x 198,000 kg / day = 41,580 kg / day
 - % VS = 19% x 198,000 kg / day = 37,620 kg / day

Biogas Volume Potential (VBS) = 0.04 m³

$$\text{Biogas Volume potentials (BVP)} = 0.04 \frac{\text{m}^3}{\text{kg}} \times 41,580 \frac{\text{kg}}{\text{day}} = 1,663.2 \text{ m}^3/\text{day}$$

The rate of gas production per m³ per day (K) is:

$$K = \frac{\text{Biogas Volume Potential (BVP)}}{\text{VS}} \times 100\% \quad (1)$$

$$K = \frac{1,663.2 \text{ m}^3/\text{day}}{37,620 \text{ kg/day}} \times 100\% = 4.42\% \approx 4\%$$

Calculation of methane gas production (VGM) was based on Harahap [12]. The calculation result:

$$\text{Gas Metan Volume (VGM)} = 65.7\% \times 1,663.2 \text{ m}^3/\text{day} = 1,092.72 \text{ m}^3/\text{day}$$

Biogas production in five mesophilic laboratory-scale biogas reactors with a substrate mixture 85 % whole stillage and 15 % manure (based on volatile solids), operating semi-continuously for 640 days at an organic loading rate at 2.8 g VS/(L x day) and a hydraulic retention time of 45 days result methane yield 0.31NL CH₄/g VS [13]. Rico reported that use of CTSR (Continuous Stirred Tank Reactor) with 1.5 m³ volume to processing the screened liquid fraction of dairy manure can produced amount of gas, 28.4% which implies that the digestive tank should be covered to capture its residual methane yield [14].

The potential of electrical energy produced from biogas can be calculated using the conversion factor (FK) as in Table 4.

$$E = \text{Gas Metan Volume (GMV)} \times FK = 1,092.72 \frac{\text{m}^3}{\text{day}} \times 4,7 \text{ kWh} = 5,135.784 \text{ kWh}$$

The calculation of electric power by biogas is as follows:

$$P = E/24 \quad (2)$$

$$P = \frac{5,135.78 \text{ kWh}}{24 \text{ h}} = 213.99 \text{ kW} \approx 214 \text{ kW}$$

Table 4. Results of calculation of estimated biogas capacity

No.	Type of Calculation Process	The calculation results
1	Potential of Cow Manure (Q)	198,000 kg/day
2	Total Solid (TS)	41,580 kg/day
3	Volatile Solid (VS)	37,620 kg/day
4	Biogas Production Volume (VBS)	1,663.2 m ³ /day
5	Volume of Methane Gas (VGM)	1,092.,72 m ³ /day
6	Electric Energy Potential (E)	5,135.78 kWh
7	Power (P)	214 kW

Recebli et al. [15] conducted research use 350 kg bovine animal manure blend (175 kg manure+175 kg water) filled to the tank and, 375 kg poultry manure blend (50 kg manure + 325 kg water) was filled to the tank and the processes done. Their results showed that daily 6.33 m³ and 0.83 m³ biogas productions and value was predicted at the values of 21,000 kJ/m³ with 62% CH₄ content. The results of Abubakar and Salim research indicate that average cumulative biogas yield and methane content observed were 0.15 L/kg VS_{added} and 47% [5].

4. Conclusion

It is concluded that the type of installation of selected biogas reactors is suitable. The results of the Modified CoLAR biogas reactor with capacity of 198,000 kg/day cow manure produced 1,663.2 m³/day of biogas that equivalent to 1,093 m³/day of methane gas. Based on these results, it was known that the potential of electrical energy produced by the installation of biogas was 5,136 kWh and 214 kW of electricity power.

References

- [1] Mengistu M G, Simane B, Eshete G, Workneh T S 2016 Factors affecting households' decisions in biogas technology adoption, the case of Ofla and Mecha Districts, Northern Ethiopia *Renew. Energy* **93** 215-227.
- [2] Thi N B D, Lin C Y, Kumar G 2015 Waste-to-wealth for valorisation of food waste to hydrogen and methane towards creating a sustainable ideal source of bioenergy *J. Clean. Prod.* **122** 29-41.
- [3] Lungkhimba H M, Amrit B K, Jagan N S 2010 Biogas production from anaerobic digestion of biodegradable household wastes *Nepal J. Sci. Technol.* **11** 167-172.
- [4] Cu T T T, Cuong P H, Hang L T, Chao N V, Anh L X, Trach N X, Sommer S G 2012 Manure management practices on biogas and non-biogas pig farms in developing countries using livestock farms in Vietnam as an example *J. Clean. Prod.* **27** 64-71.
- [5] Abubakar B S U I, Ismail N 2012 Anaerobic digestion of cow dung for biogas production *ARPN JEAS* **7** 2 169-172.
- [6] Bruun S, Jensen L S, Vu V T K, Sommer S 2014 Small-scale household biogas digesters: An option for global warming mitigation or a potential climate bomb? *Renew. Sustain. Energy Rev.* **33** 736-741.
- [7] Roubík H, Mazancová J, Le Dinh P, Dinh Van D, Banout J 2018 Biogas quality across small-scale biogas plants: a case of Central Vietnam *Energies* **11** 7 1-12.
- [8] Zhang L X, Wang C B, Song B 2013 Carbon emission reduction potential of a typical household biogas system in rural China *J. Clean. Prod.* **47** 415-421.
- [9] Hamilton D 2012 Types of Anaerobic Digester accessed December 12 2017. <http://articles.extension.org/pages/30307/types-of-anaerobic-digesters>.
- [10] Isdiyanto R, Hasanuddin U 2010 Engineering and Performance Testing of The Colar System Biogas Reactor in Tapioca Industrial Wastewater *Ketenaga listrikan dan Energi Terbarukan* **9** 1 14-26. [In Indonesian]
- [11] Widodo T W, Hendriadi A 2005 Development of Biogas Processing for Small Scale Cattle Farm in Indonesia. p 255-261. Proc. International Seminar on Biogas Technology for Poverty Reduction and Sustainable Development. Beijing, 17-20 October 2005
- [12] Harahap F M, Apandi, Ginting 1978 Gas Bio Technology Bandung Institut of Technology Bandung Indonesia. [In Indonesian]
- [13] Westerholm M, Hansson M, Schnürer A 2012 Improved biogas production from whole stillage by co-digestion with cattle manure *Bioresour. Technol.* **114** 314-319.
- [14] Rico C, Rico J L, Tejero I, Munoz N, Gomez B 2011 Anaerobic digestion of the liquid fraction of dairy manure in pilot plant for biogas production: residual methane yield of digestate *Waste Manag.* **31** 9-10 2167-2173.

- [15] Recebli Z, Seliml S, Ozkaymak M, Gonc O 2015 Biogas production from animal manure *JESTEC* **10** 6 722-729.